

## Drug Test Cassette Assembly Machine

2 Strips & 3 Strips Cassette Automated Assembly



### Requirement:

1. 2 strips cassette & 3 strips cassette share one line
2. 3 strips cutter
3. Robots automated assembly
4. Laser printer integrated
5. Connect to pouch paking machine

## Drug Test Cassette Assembly Machine

2 Strips & 3 Strips Cassette Automated Assembly

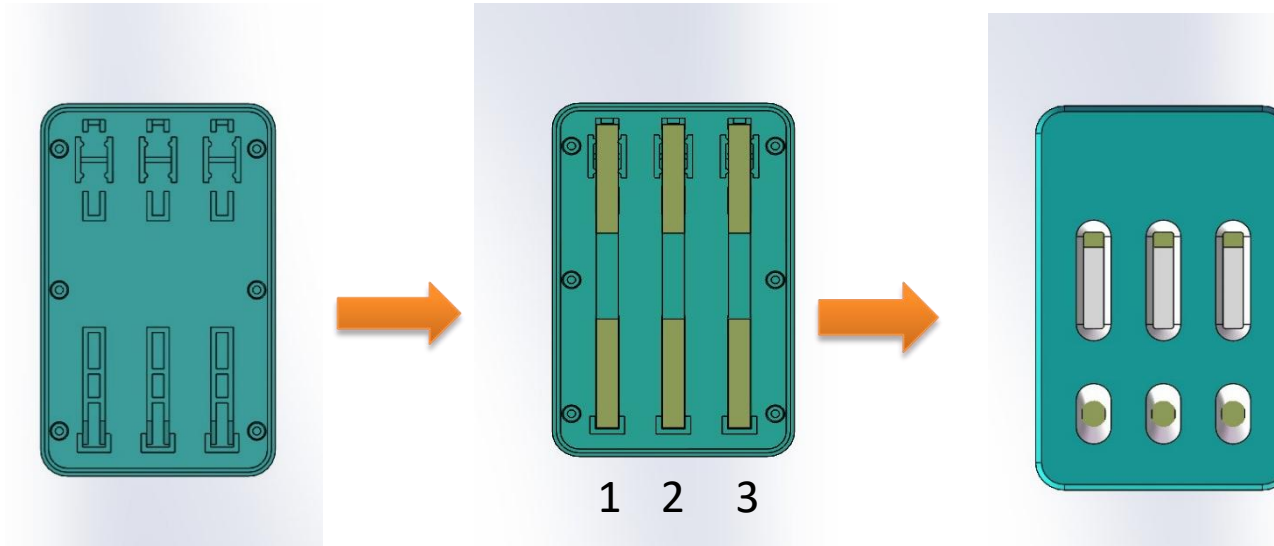

### Requirement:

1. 2 strips cassette & 3 strips cassette share one line
2. 3 strips cutter
3. Robots automated assembly
4. Laser printer integrated
5. Connect to pouch paking machine

## Drug Test Cassette Assembly Machine

2 Strips & 3 Strips Cassette Automated Assembly

### Uncut sheet dimension

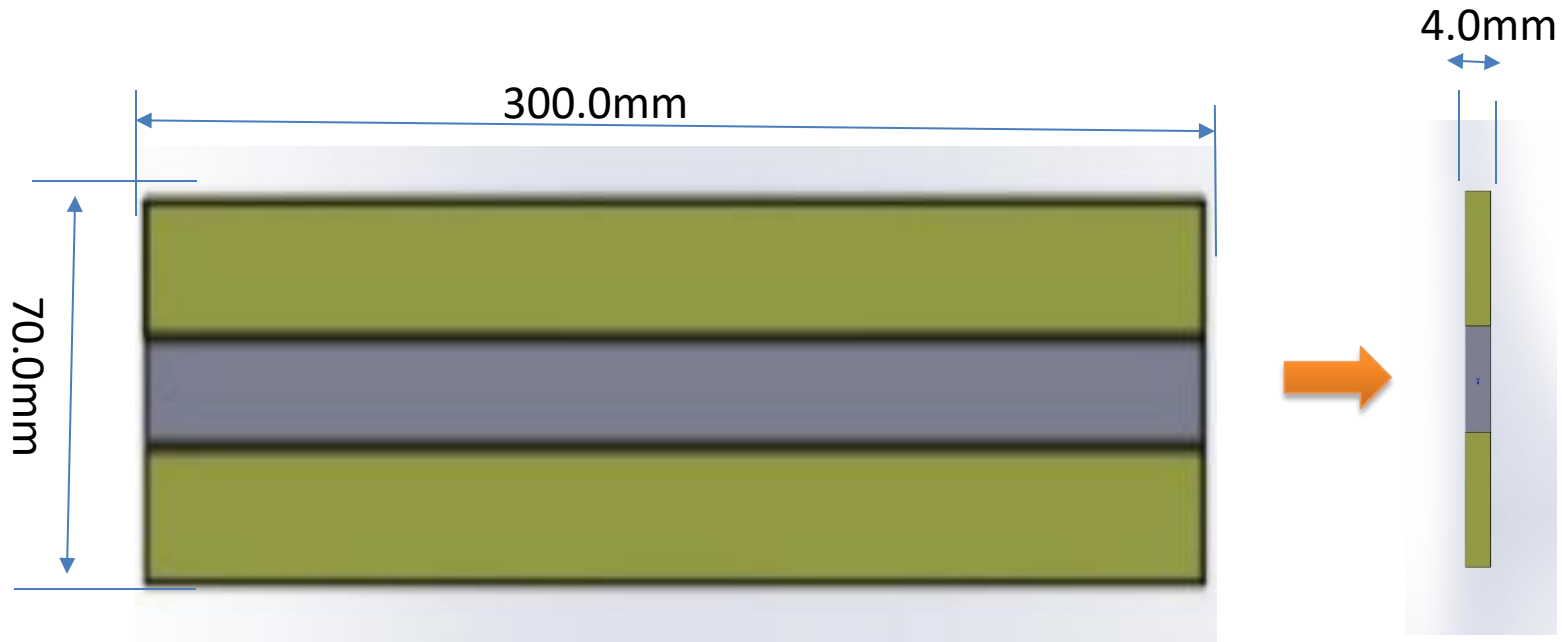

## Drug Test Cassette Assembly Machine

2 Strips & 3 Strips Cassette Automated Assembly

### Dimension

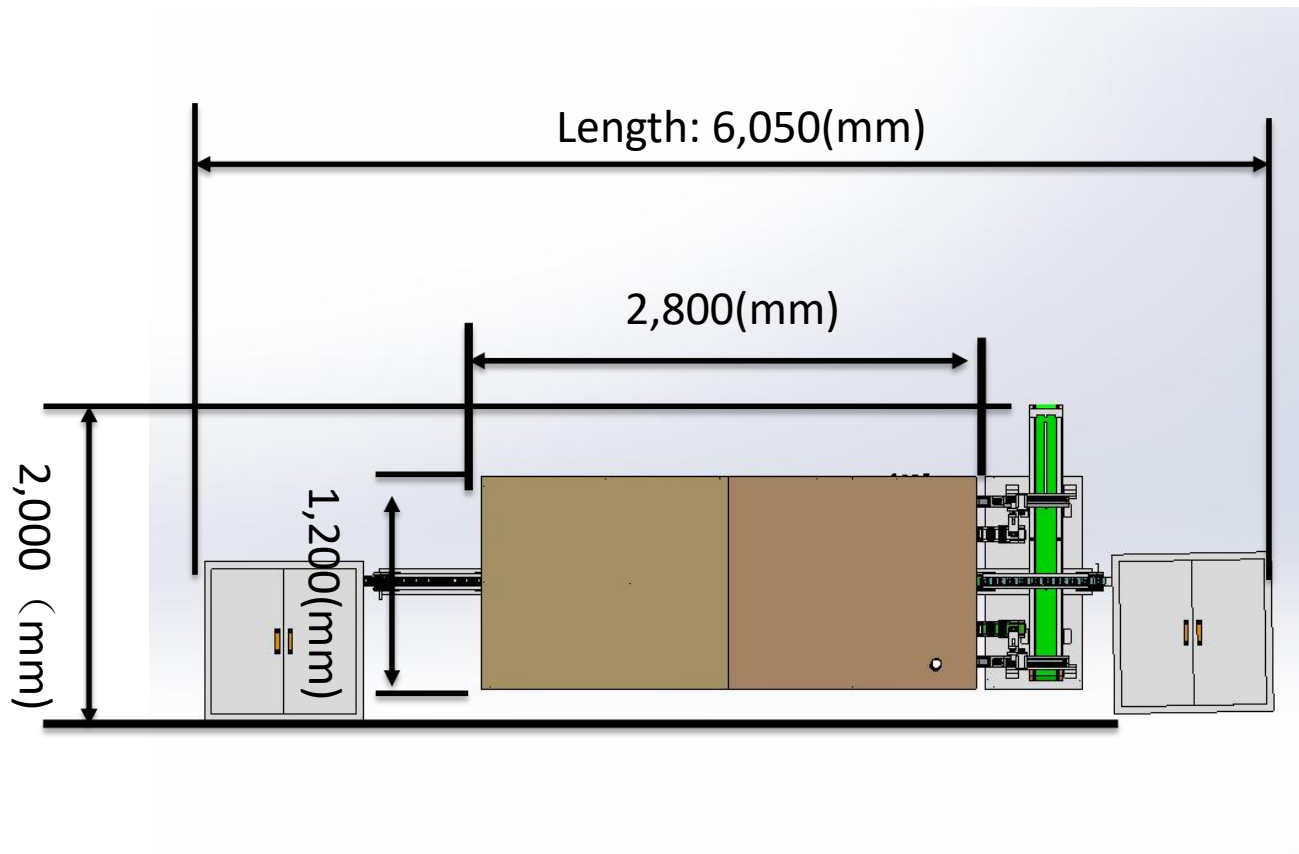

# Drug Test Cassette Assembly Machine

## 2 Strips & 3 Strips Cassette Automated Assembly

### Overview

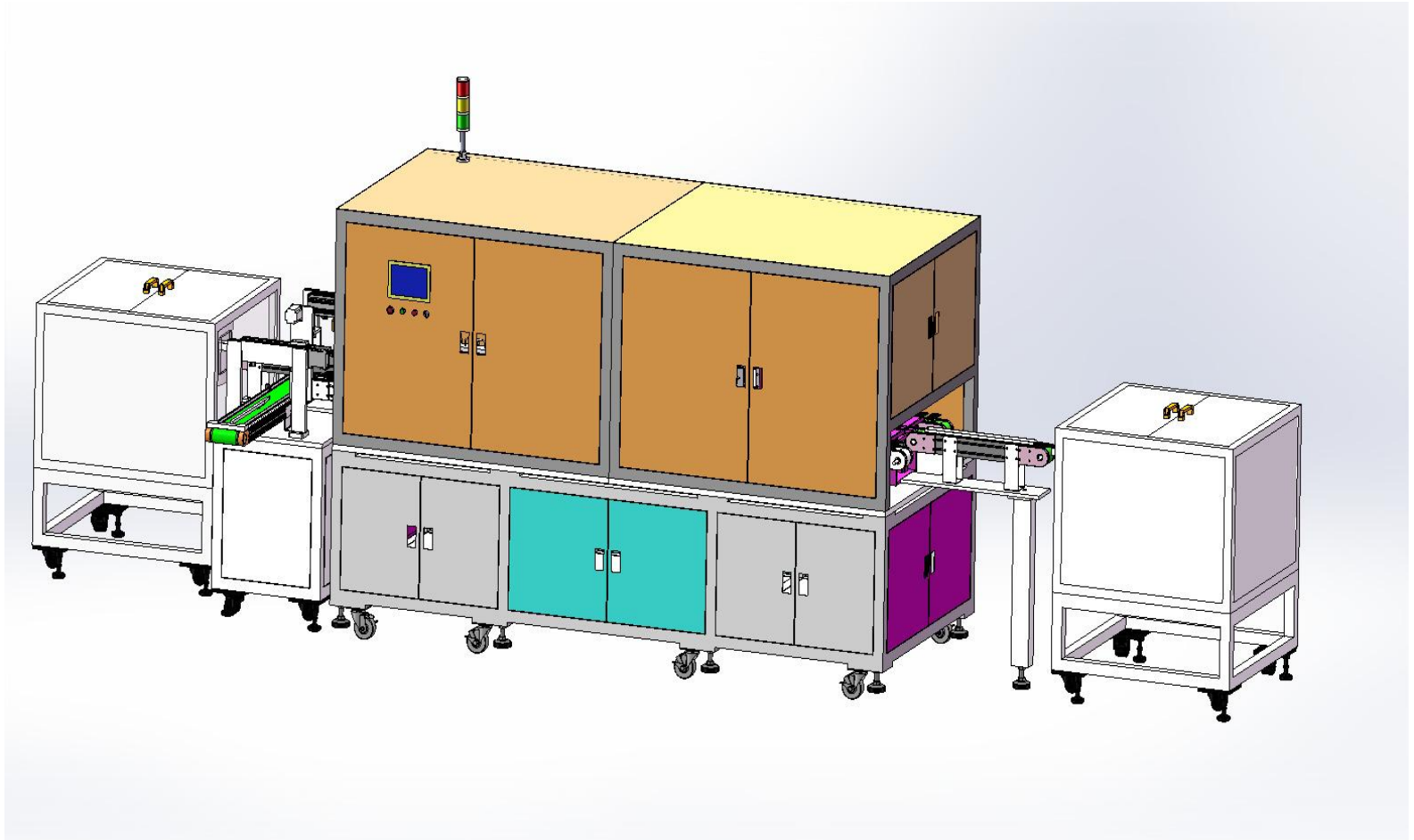

# Drug Test Cassette Assembly Machine

## 2 Strips & 3 Strips Cassette Automated Assembly

### Overview

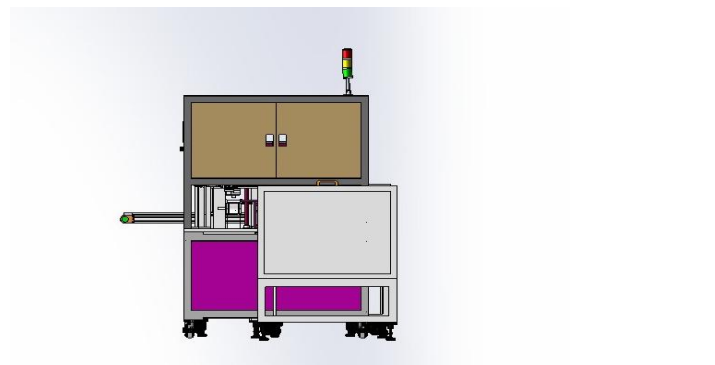
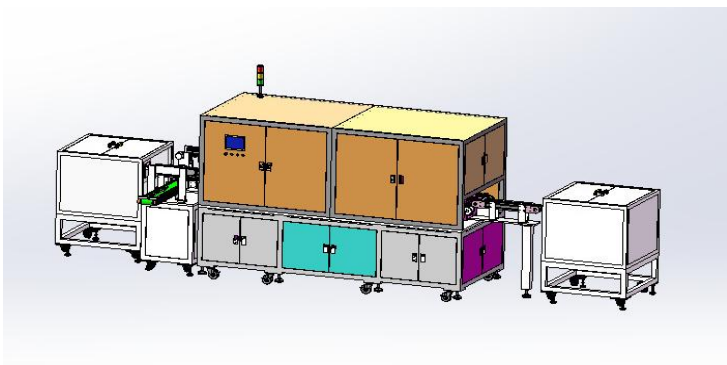
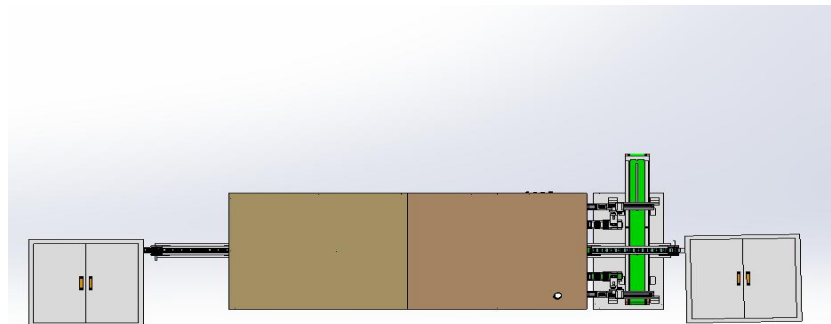
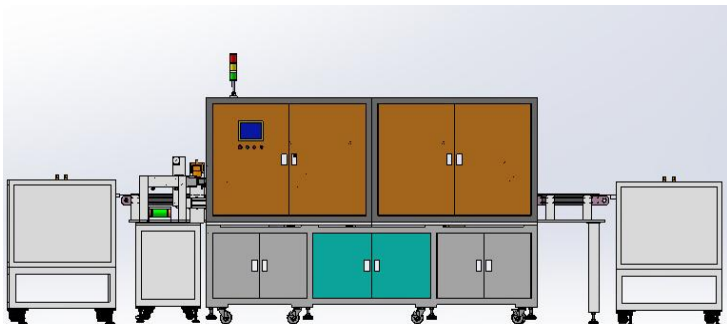

# Drug Test Cassette Assembly Machine

## 2 Strips & 3 Strips Cassette Automated Assembly

### Workstations

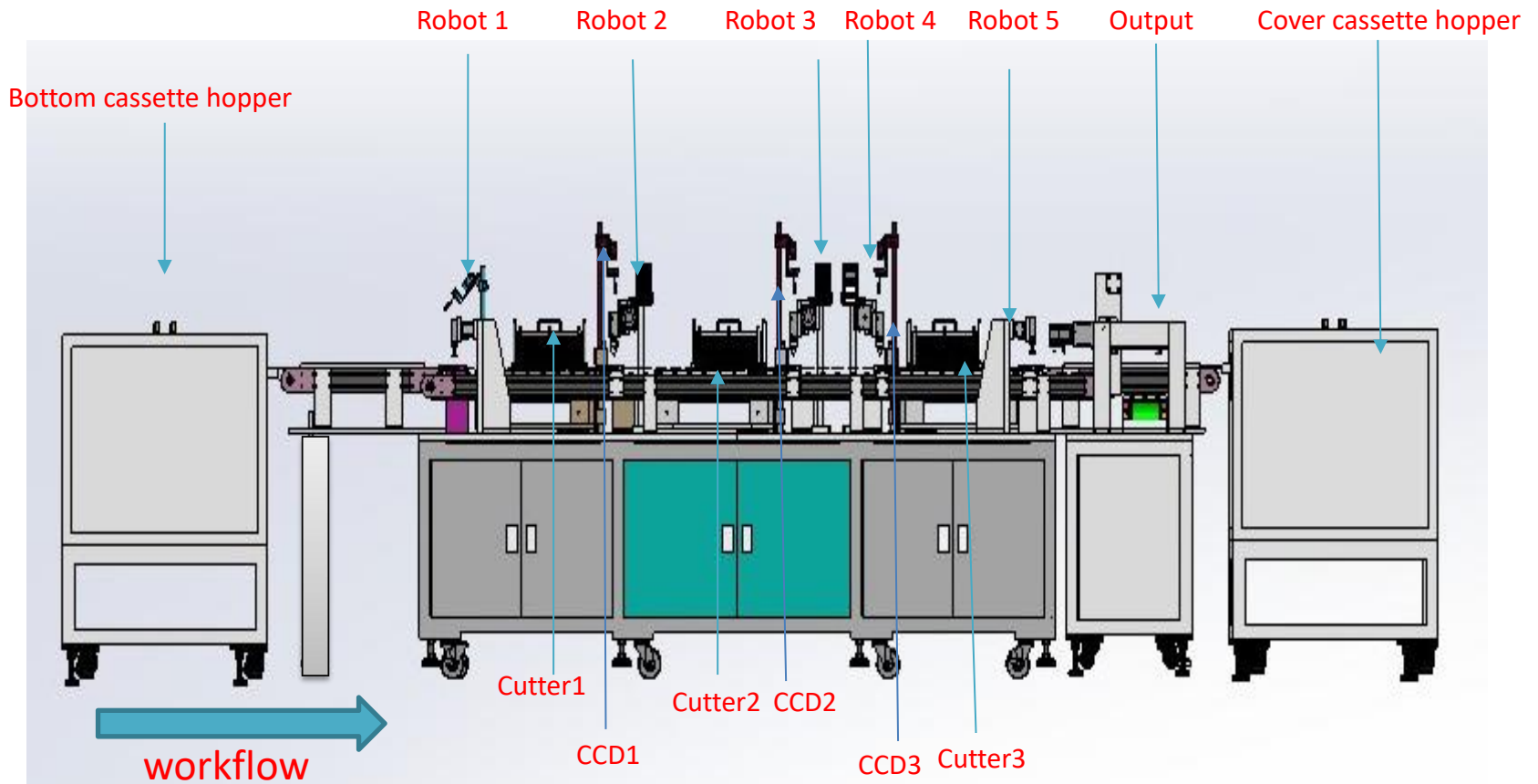

# Drug Test Cassette Assembly Machine

## 2 Strips & 3 Strips Cassette Automated Assembly

### Workstations

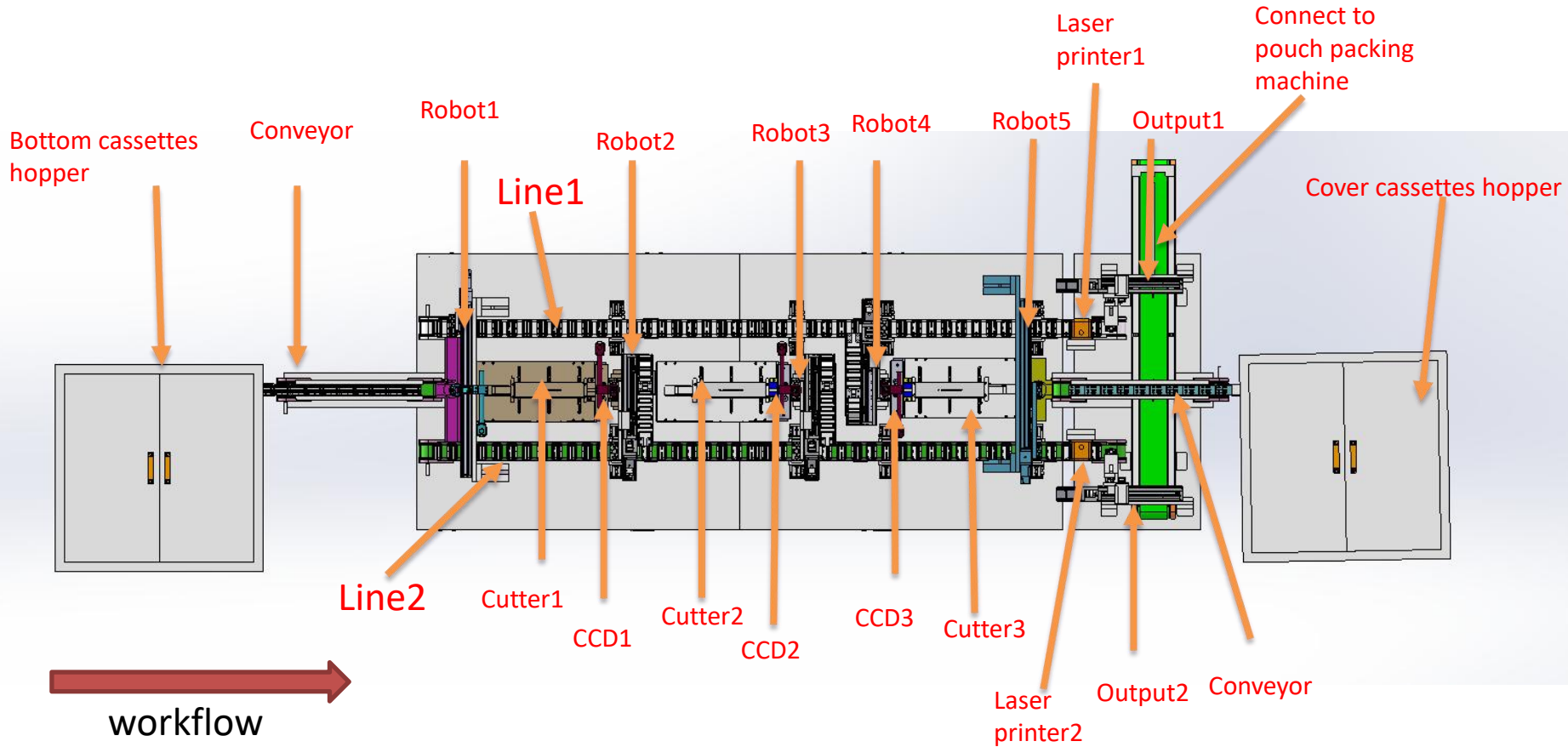



## Drug Test Cassette Assembly Machine

2 Strips & 3 Strips Cassette Automated Assembly

### Bottom cassettes hopper

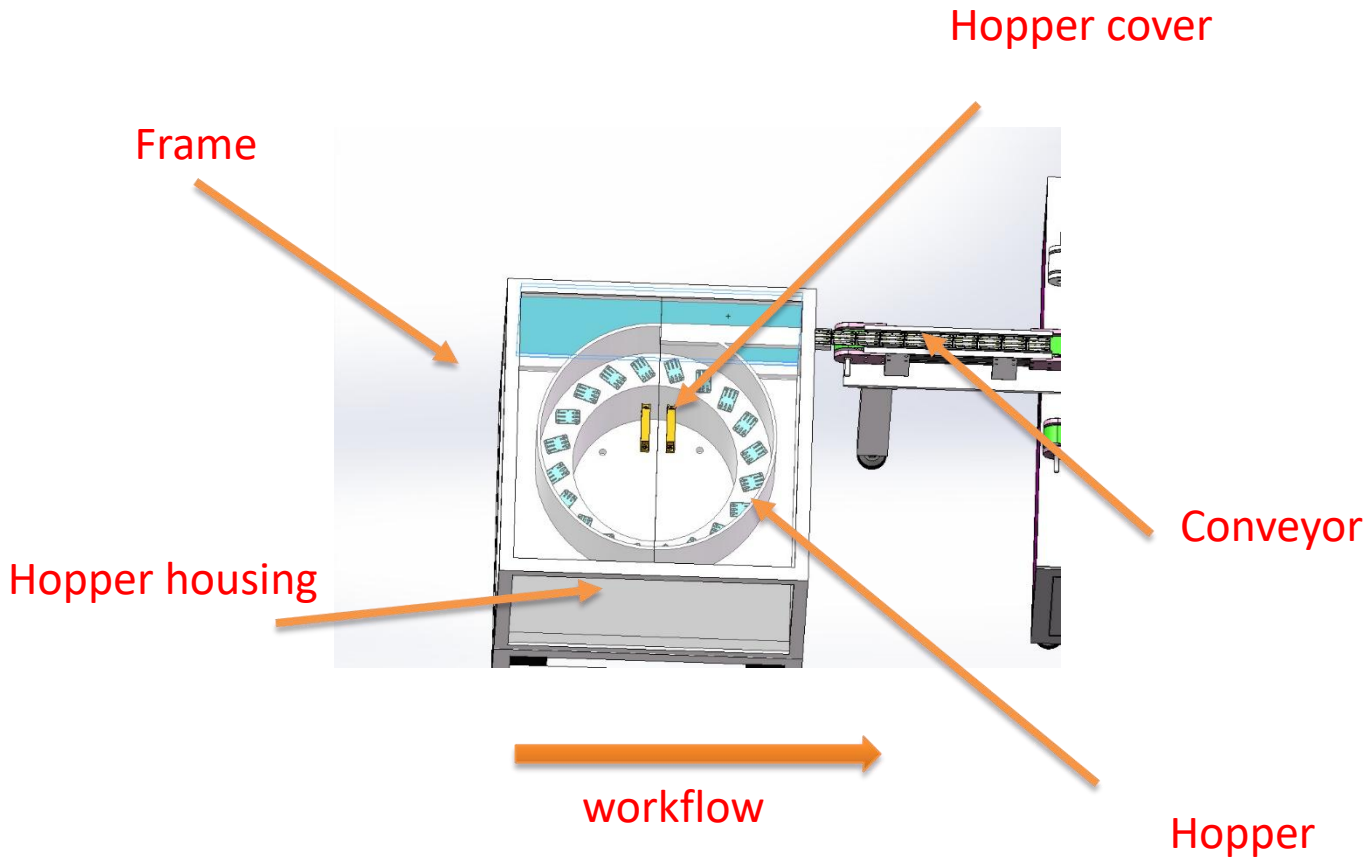

## Drug Test Cassette Assembly Machine

2 Strips & 3 Strips Cassette Automated Assembly

### Bottom cassettes feeding

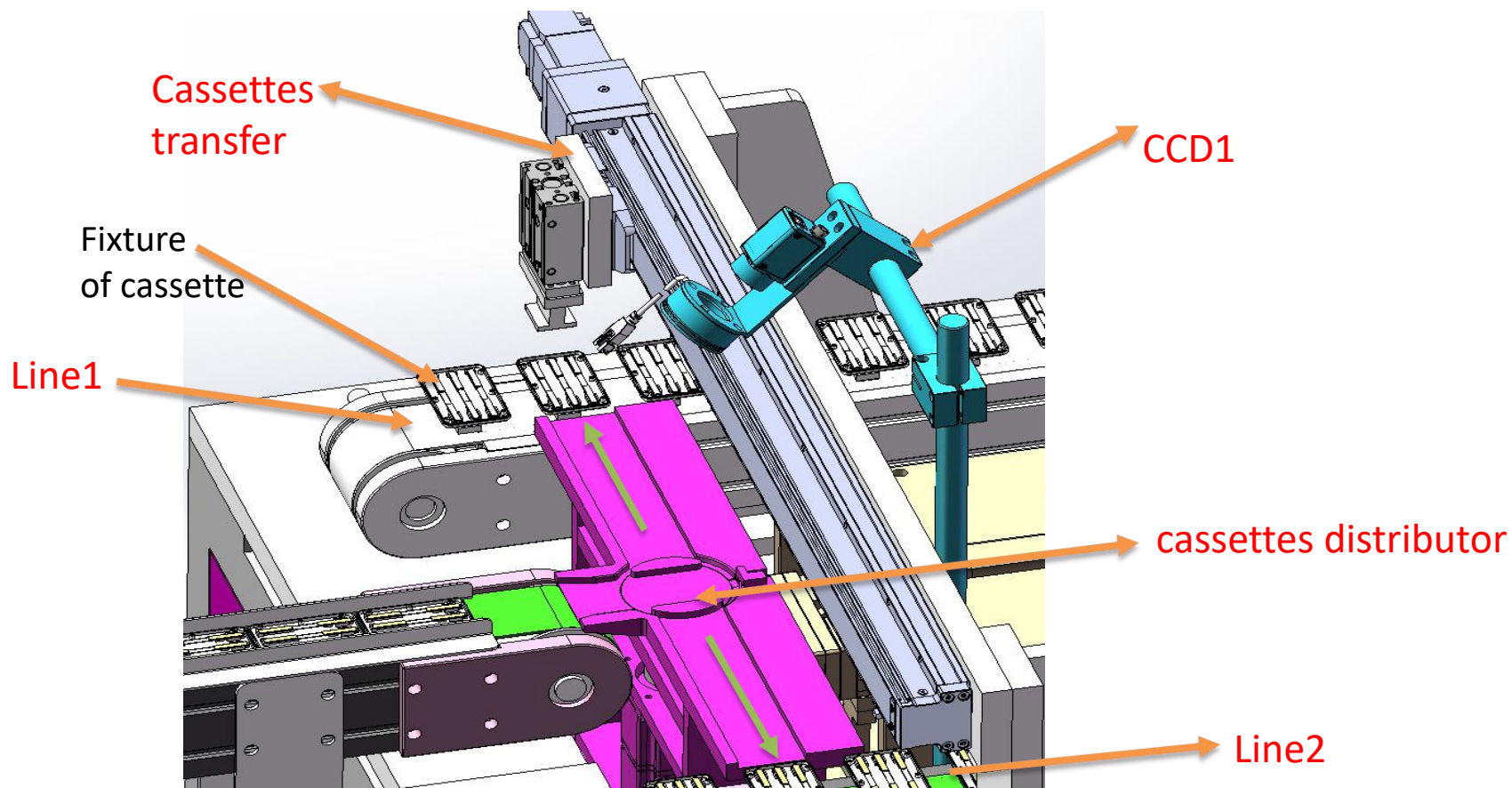

# Drug Test Cassette Assembly Machine

## 2 Strips & 3 Strips Cassette Automated Assembly

### Cutter1

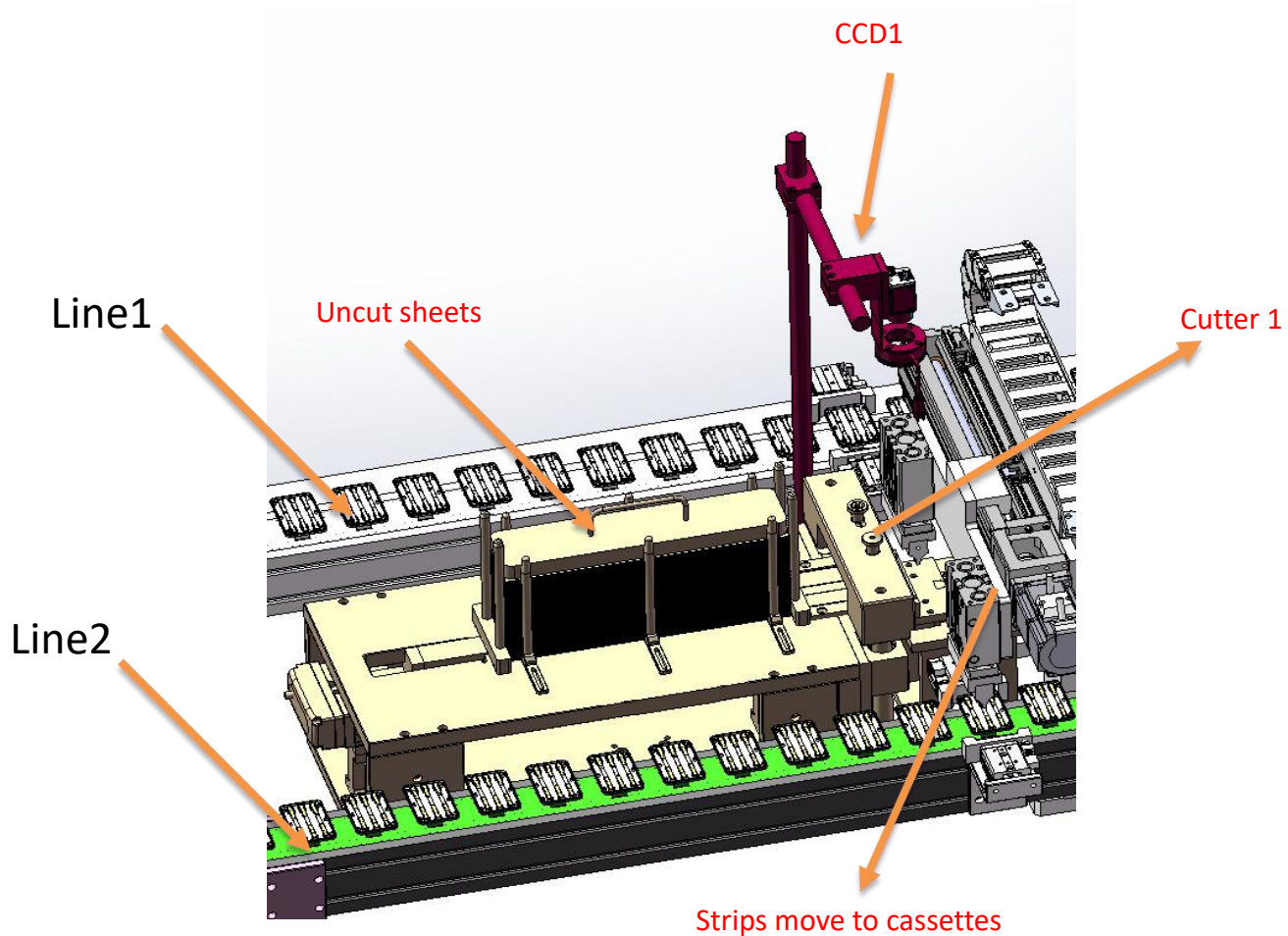

## Drug Test Cassette Assembly Machine

2 Strips & 3 Strips Cassette Automated Assembly

### Cutter2

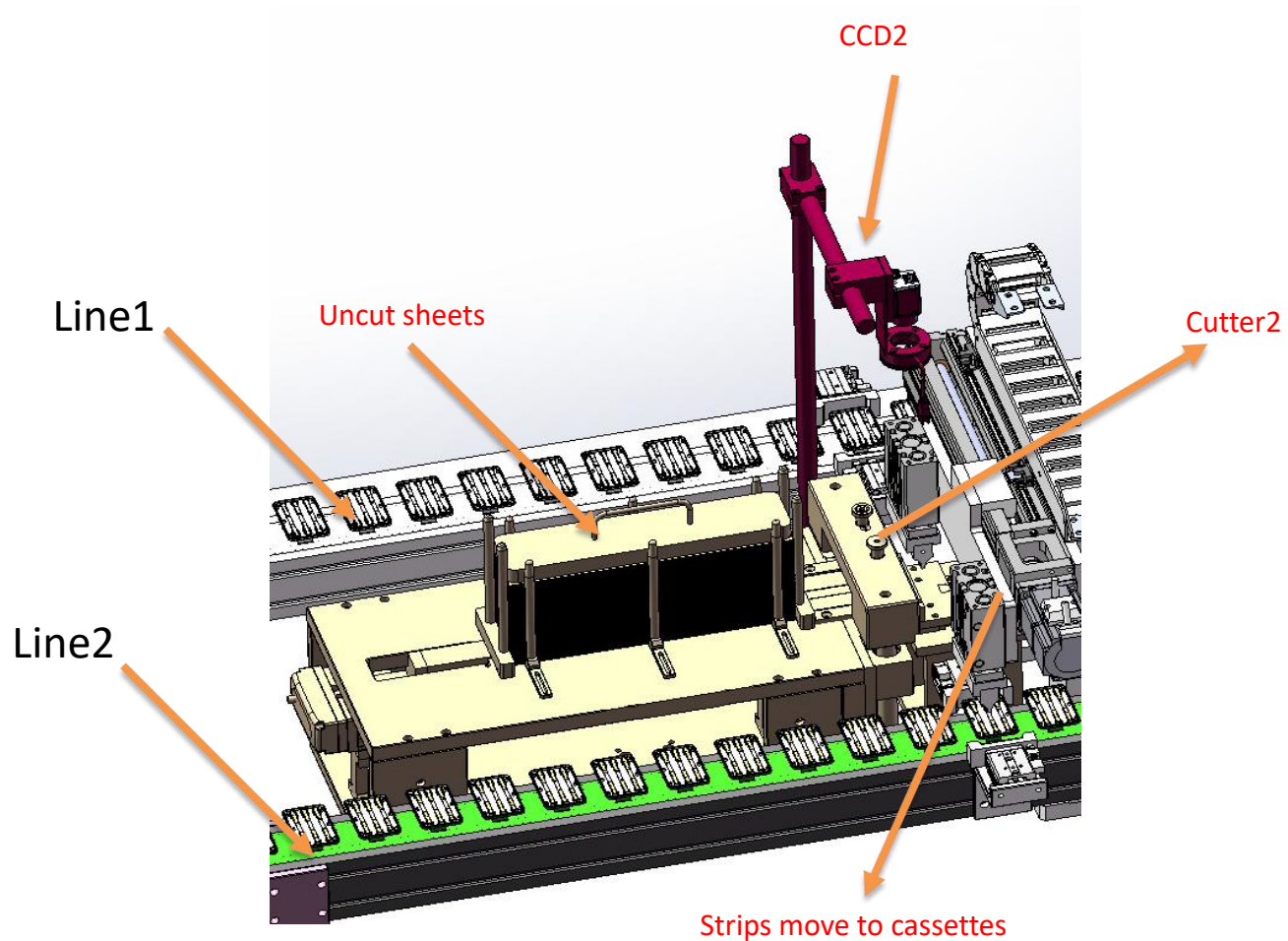

# Drug Test Cassette Assembly Machine

## 2 Strips & 3 Strips Cassette Automated Assembly

### Cutter3

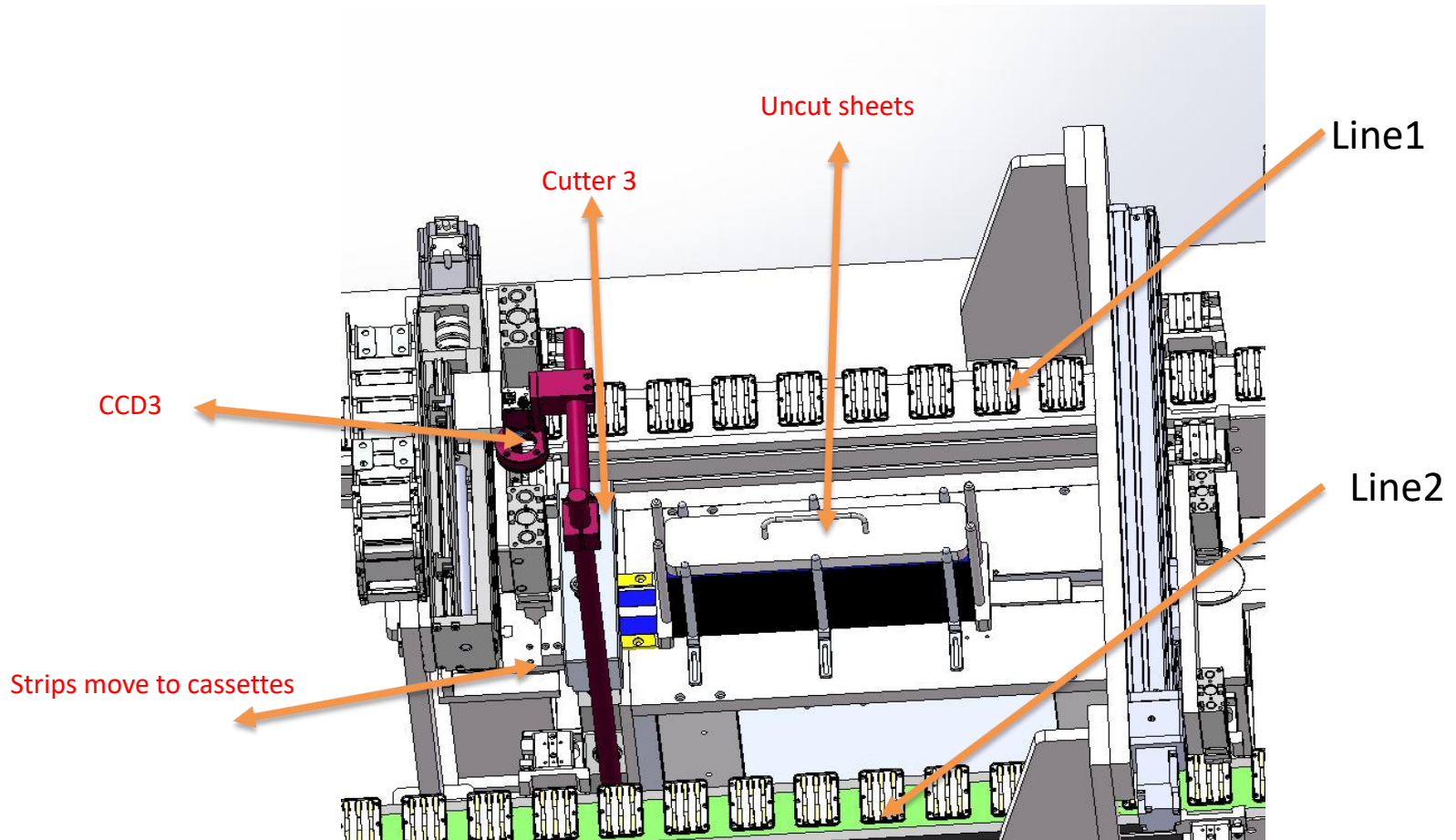

## Drug Test Cassette Assembly Machine

2 Strips & 3 Strips Cassette Automated Assembly

Laser printer

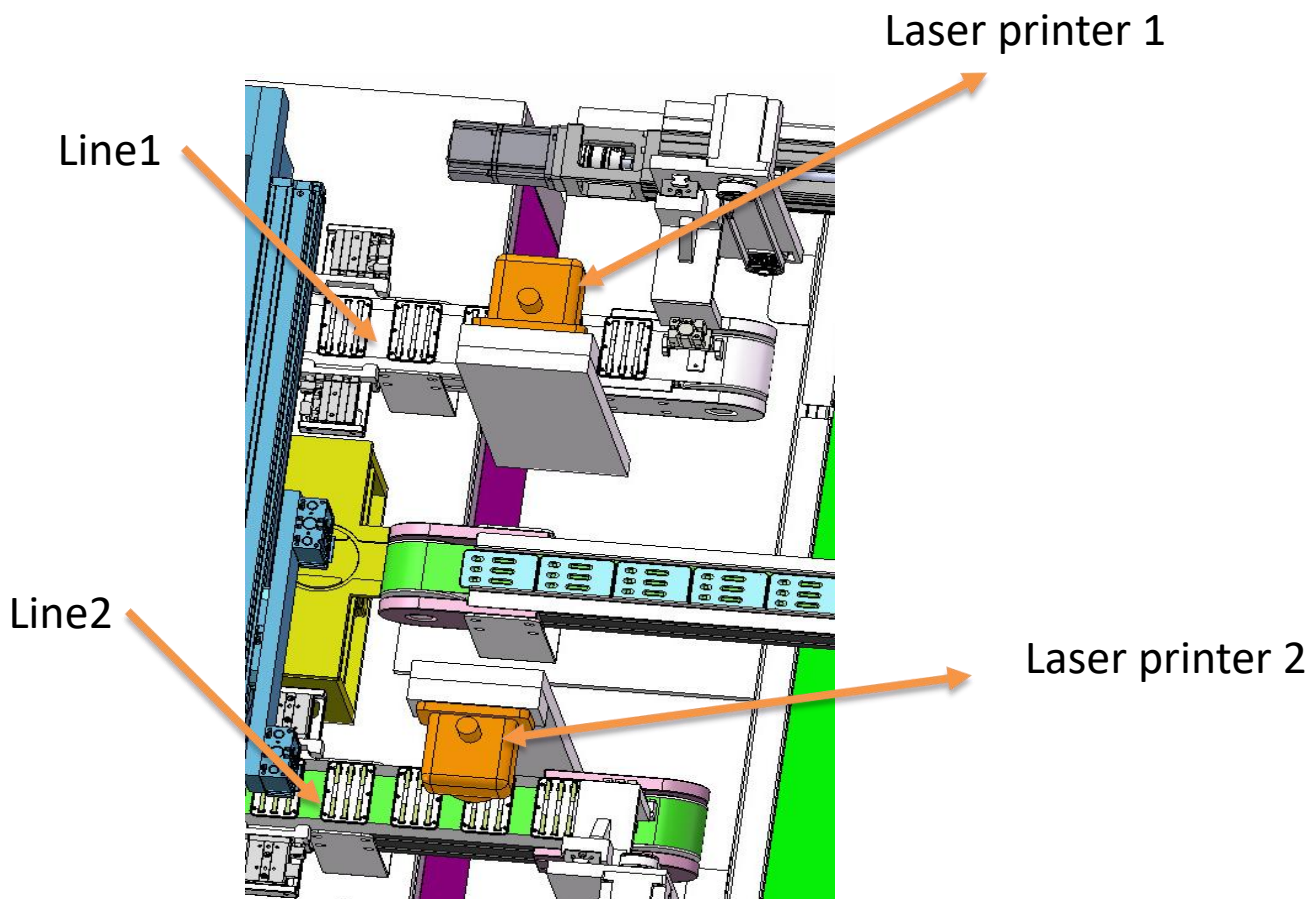

## Drug Test Cassette Assembly Machine

2 Strips & 3 Strips Cassette Automated Assembly

### Cover cassettes hopper

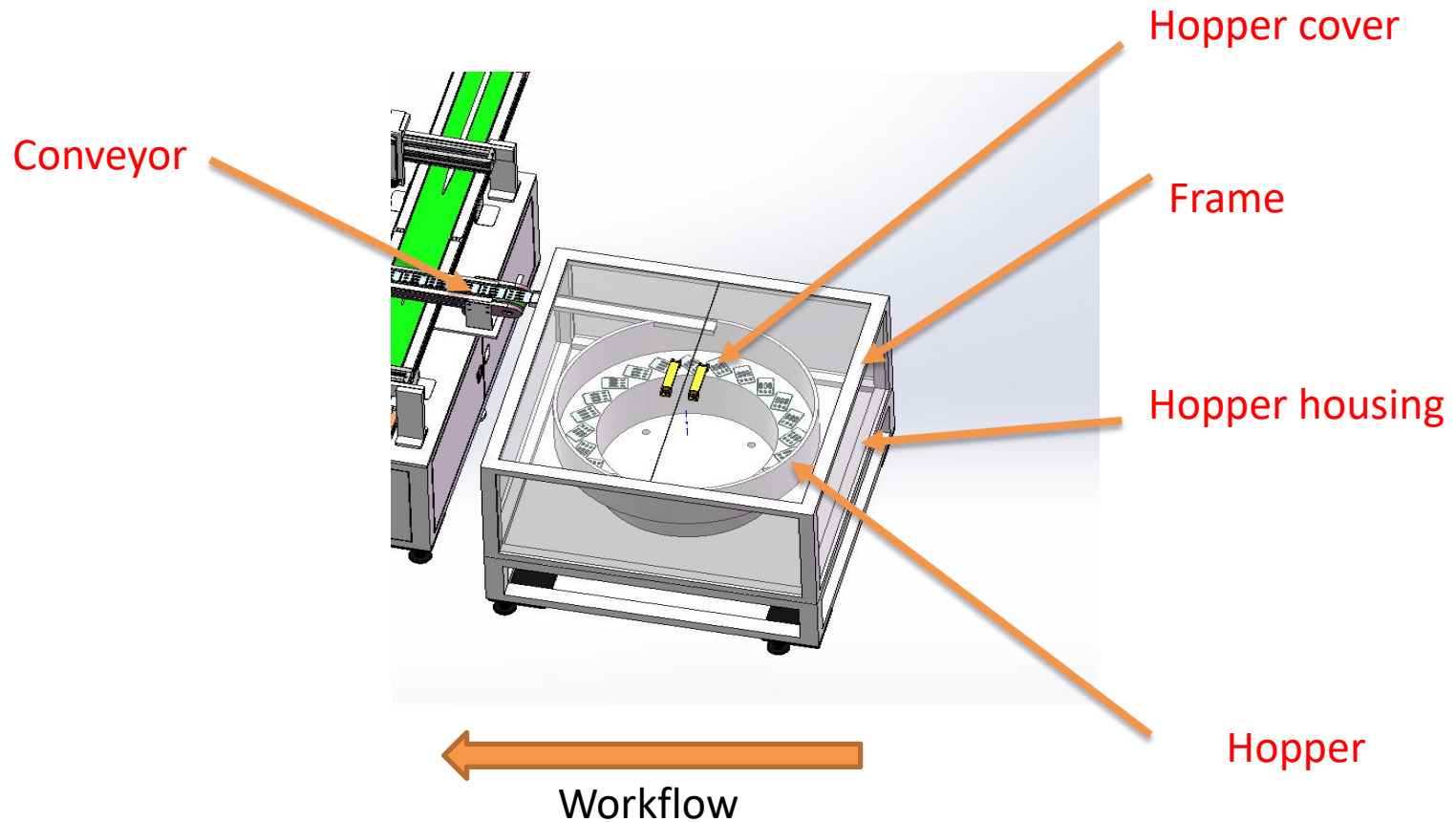

## Drug Test Cassette Assembly Machine

2 Strips & 3 Strips Cassette Automated Assembly

### Cover cassettes feeding

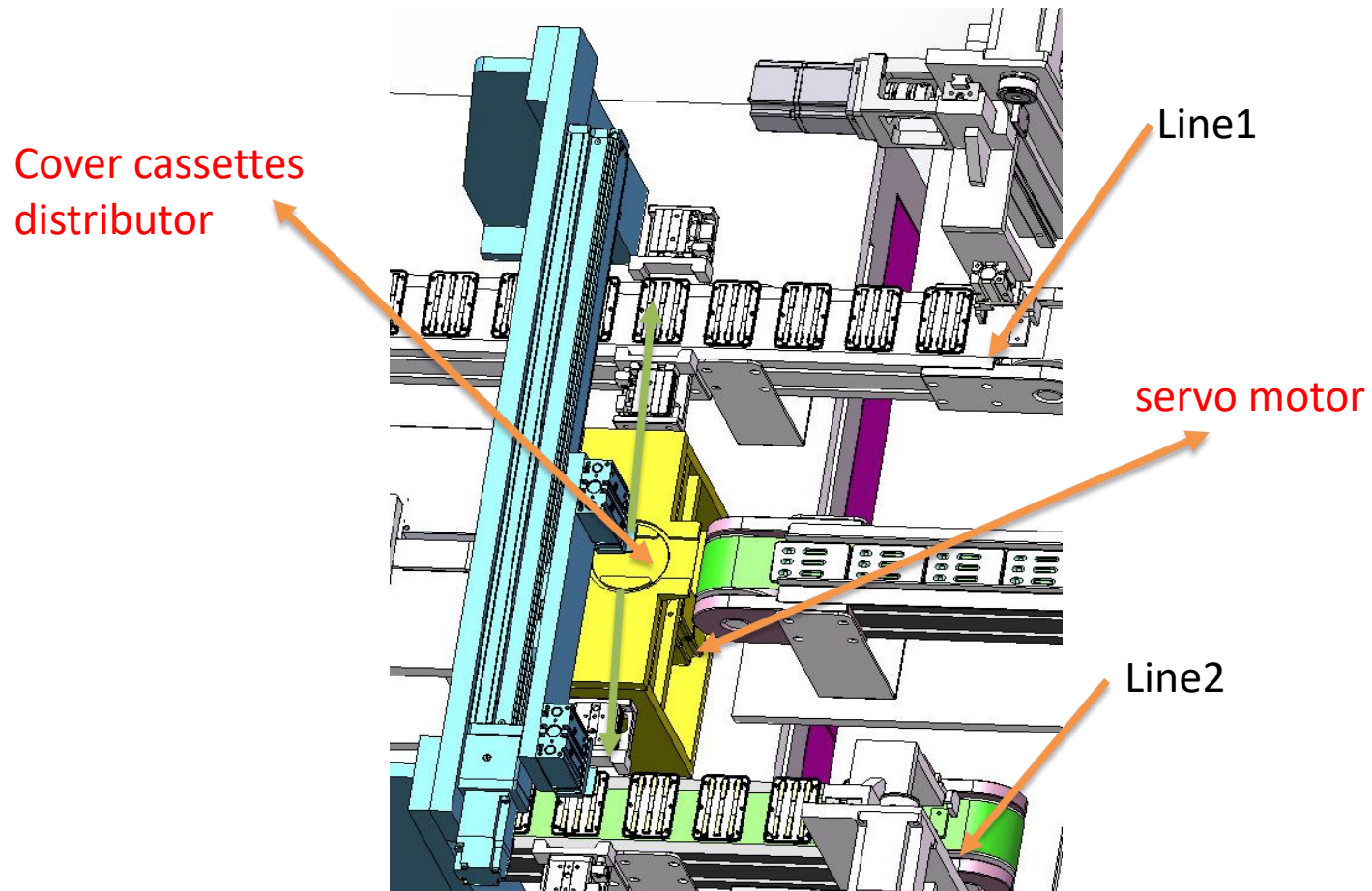



## Drug Test Cassette Assembly Machine

2 Strips & 3 Strips Cassette Automated Assembly

### Pressing cassette

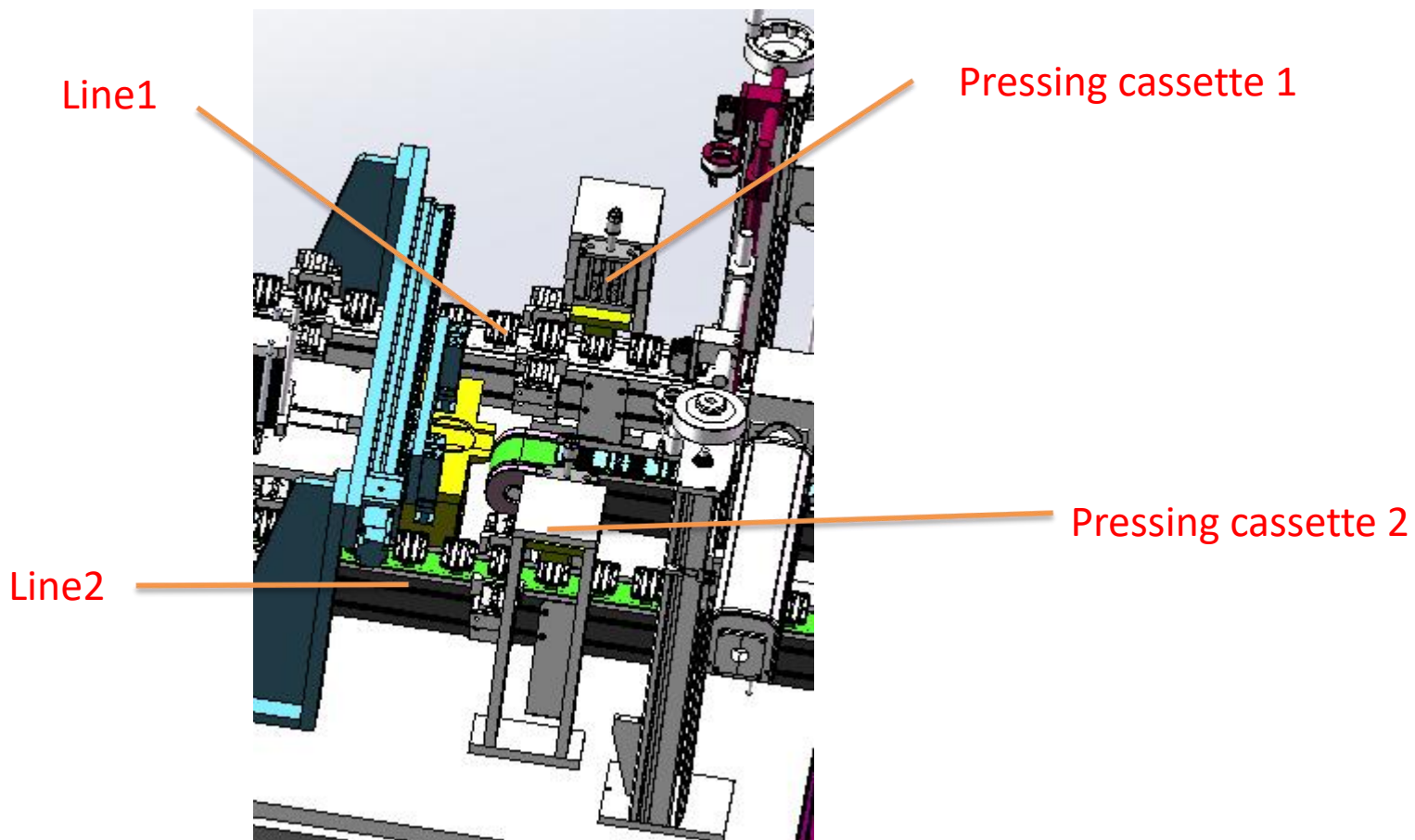

## Drug Test Cassette Assembly Machine

2 Strips & 3 Strips Cassette Automated Assembly

### Pressing cassette

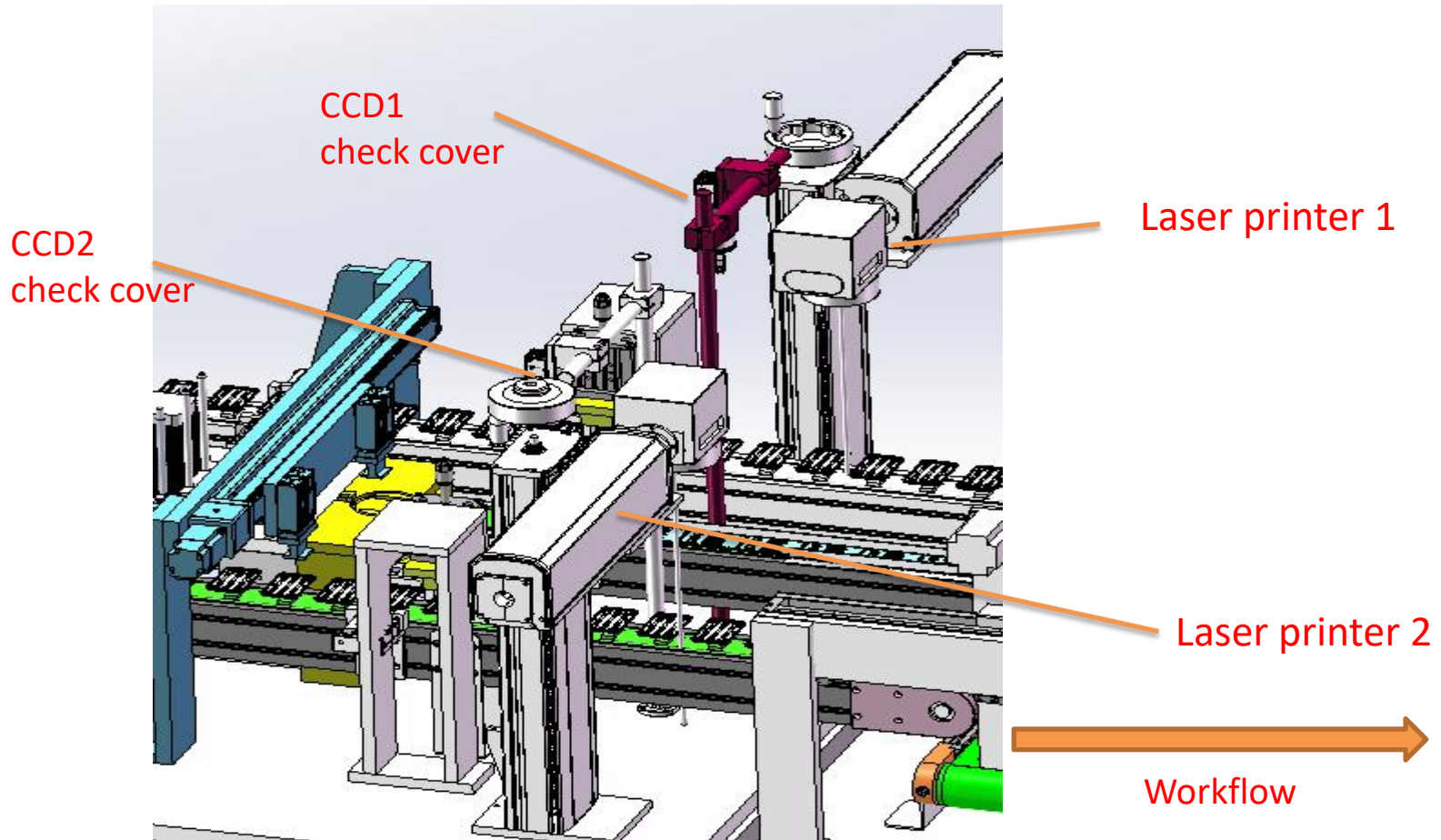

## Drug Test Cassette Assembly Machine

2 Strips & 3 Strips Cassette Automated Assembly

**Output station**

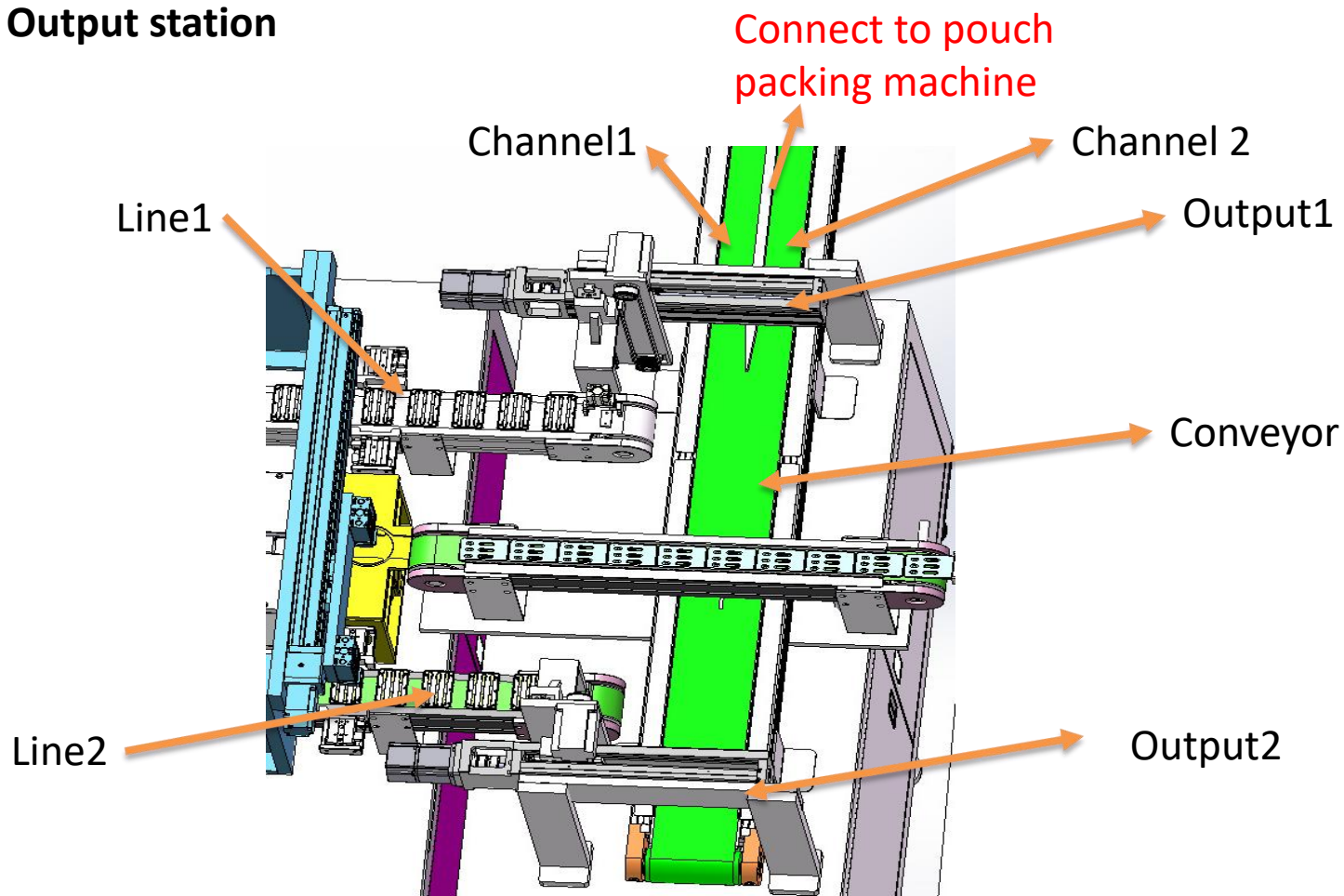

## Drug Test Cassette Assembly Machine Drug Test Cassette Pouch Packing Machine

### Two machines connection

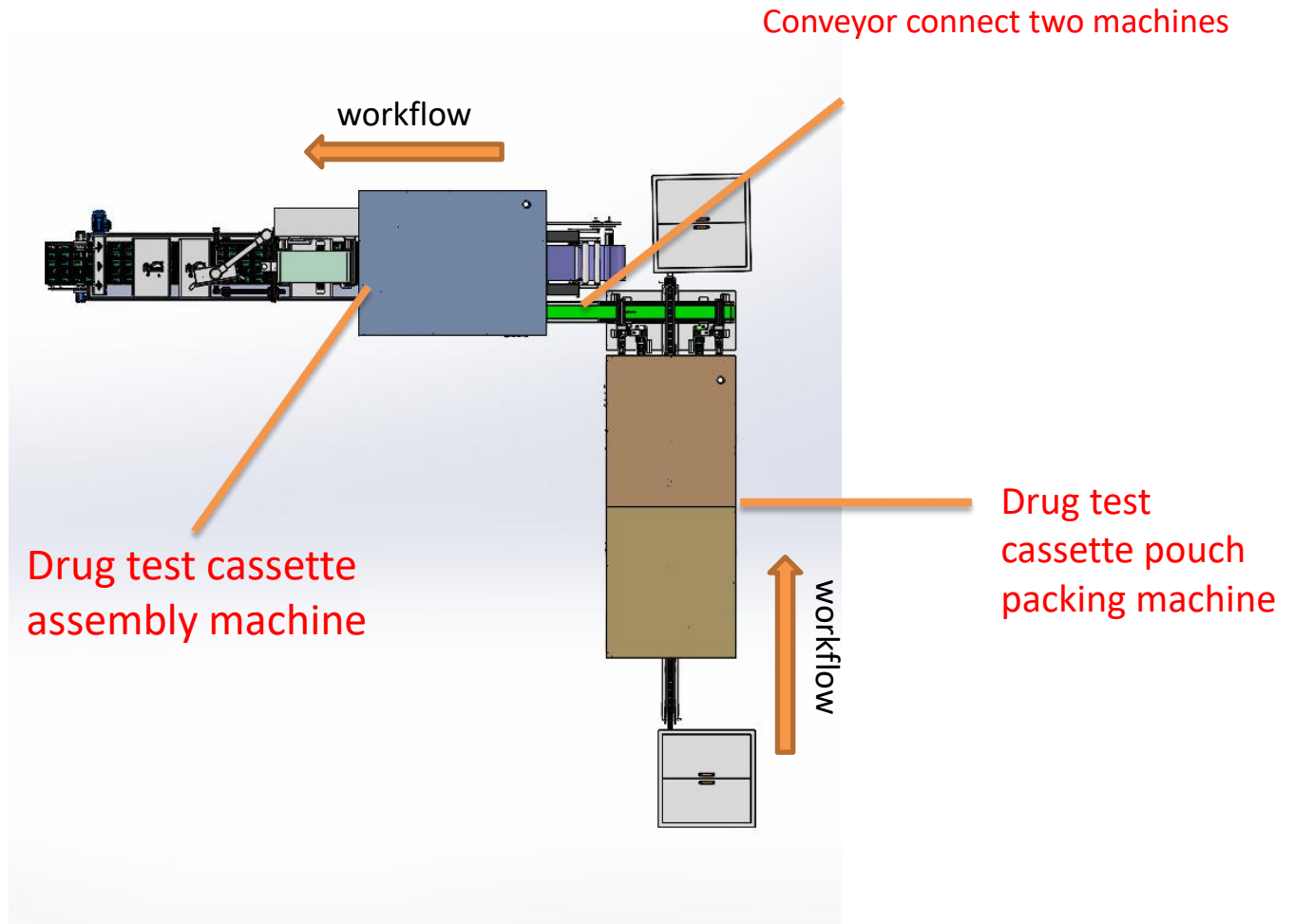

## Drug Test Cassette Assembly Machine Drug Test Cassette Pouch Packing Machine

### Two machines connection

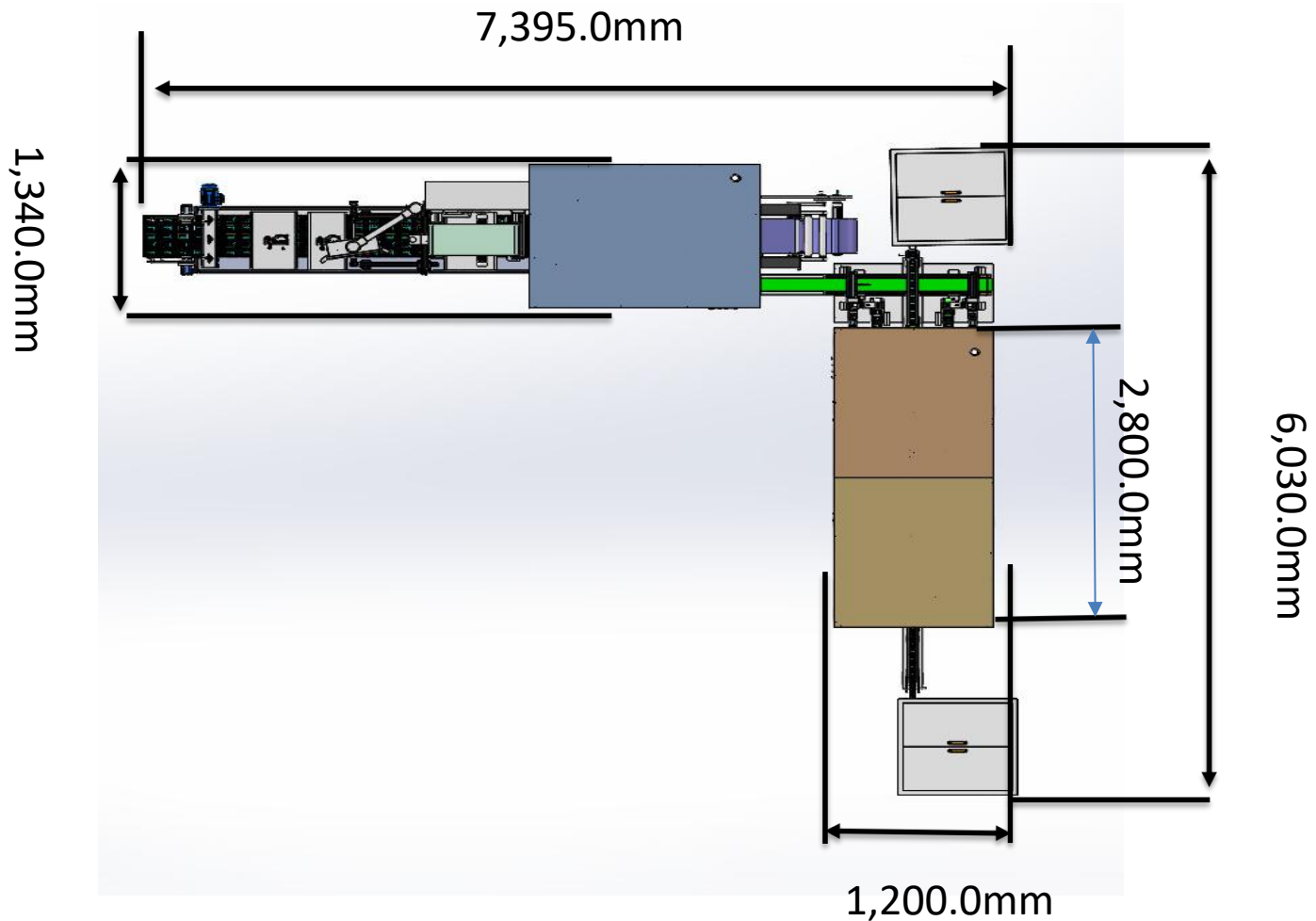

## Drug Test Cassette Assembly Machine

**2 strips cassette    EXCHANGE    3 strips cassette**

### Do as follow steps

1. Change cassette (cover/bottom) hoppers
2. Change the fixtures of cassette on Line1 and Line2
3. If assembly 2 strips cassette, then turn off the **strip cutter 3**
4. CCD scanner change parameters of 2 strip cassette or 3 strip cassette
5. Choose the proper program to run
6. Start running machine

# **Drug Test Cassette Assembly Machine**

## 2 Strips & 3 Strips Cassette Automated Assembly

### **Features:**

1. Touch screen
2. Capacity: 3,000 cassettes per hour
3. Automated cutting strips
4. NG strips remove
5. Easy to use

### **Operation:**

1. Connect power supply and air supply
2. Place cassettes into hopper
3. Place uncut sheets into loader
4. Place uncut sheets into loader
5. Start running

## Drug Test Cassette Assembly Machine

2 Strips & 3 Strips Cassette Automated Assembly

Parameters	
Capacity	3,000 cassettes/H
Activation	85%
Air supply	0.5~0.8MPa
Power supply	AC220V/50Hz
Internal power	DC/24V
Power	23.0 KW
Weight	1,500kg
Dimension	L6.05 * W2.0 * H1.8m



## Drug Test Cassette Assembly Machine

2 Strips & 3 Strips Cassette Automated Assembly

Key components	
PLC	Mitsubishi/Panasonic/other
Operation system	ANTITECK
Servo	Inovance/KNK
Relay	Schneider/CHNT
Sensor	OMRON/Panasonic
Cylinder	SMC/AIRTAC
Solenoid valve	SMC/AIRTAC
Connector	SMC/AIRTAC