

Lateral Flow Dispenser 20 pumps for 20 test lines

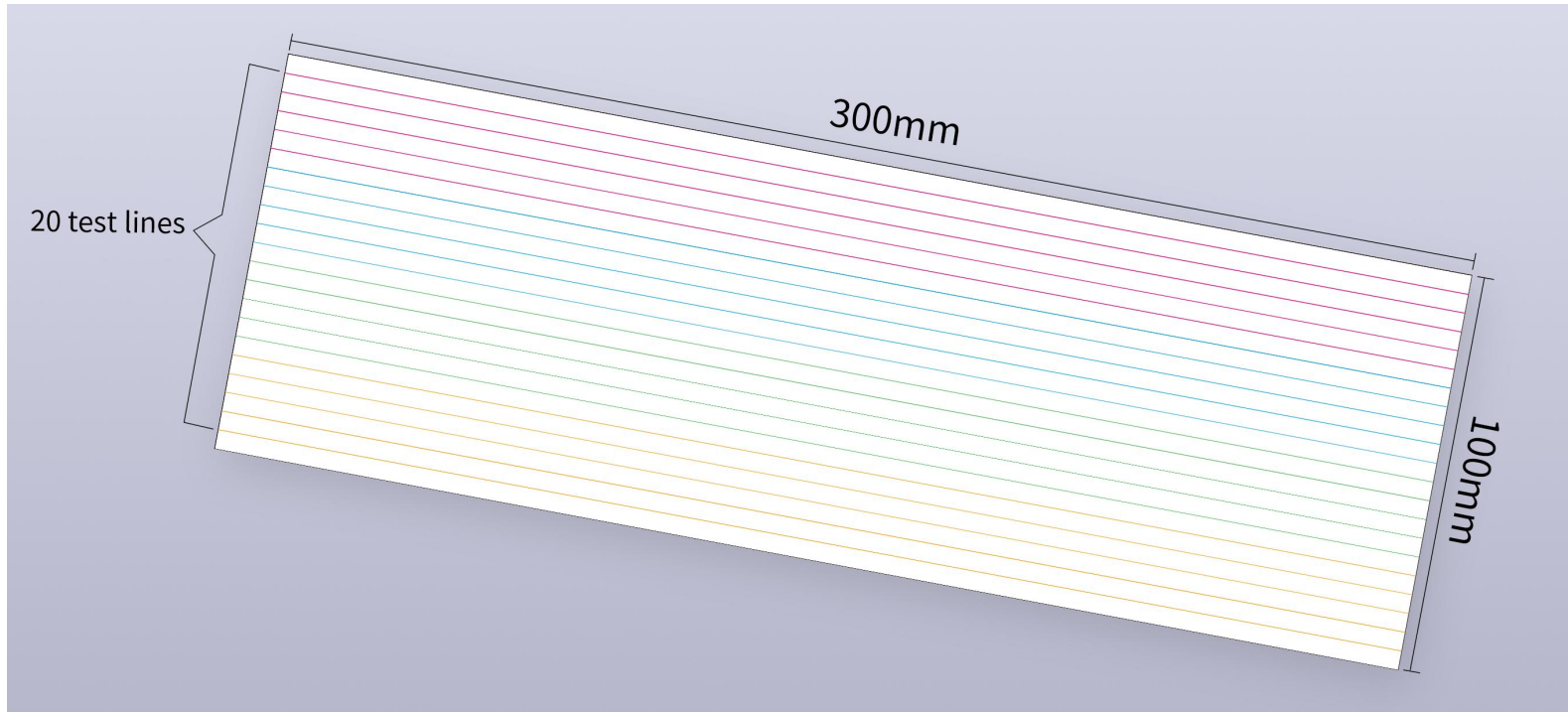

Each pump contain different reagent, individual adjust dispensing volume

Lateral Flow Dispenser 20 pumps for 20 test lines

XYZ 20TL Dispensing System

Dimension:

1,000*1,600*1,800mm

Pumps: 20

Modules: 5 (each contain 5 pumps)

Dispens area: 300*100mm

Capacity: 140 - 200 sheets/hour

Power: 220V, 2.5KW;

Air: 5-7Kgf/cm²

Programmable X, Y and Z axes

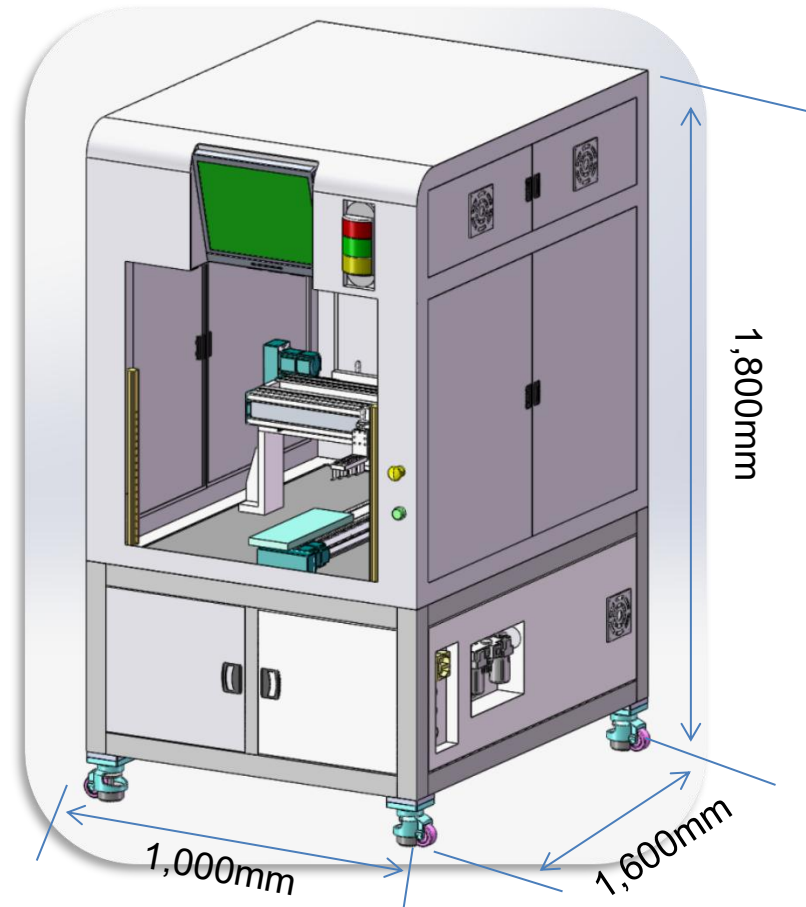

Lateral Flow Dispenser

20 pumps for 20 test lines

Overview

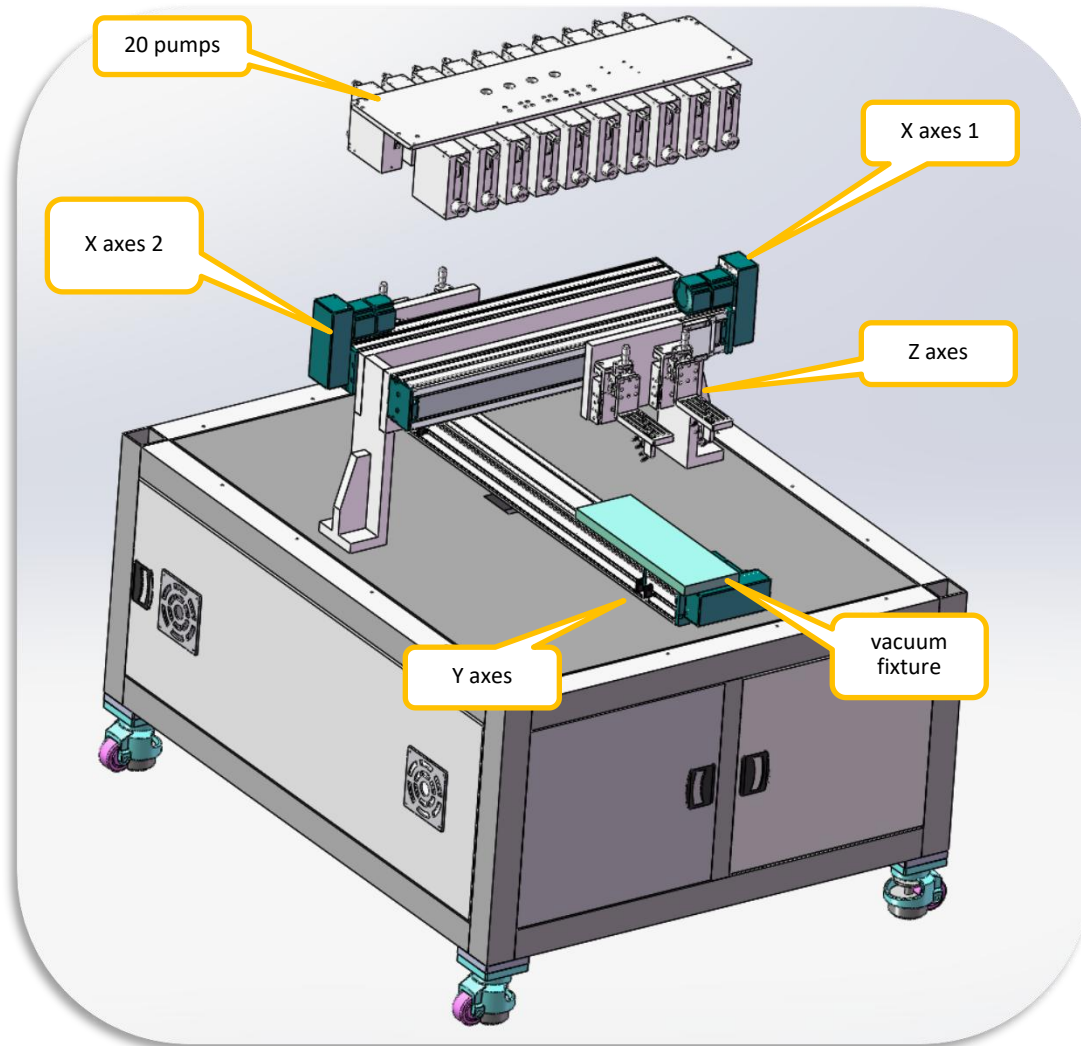

Lateral Flow Dispenser

20 pumps for 20 test lines

Overview

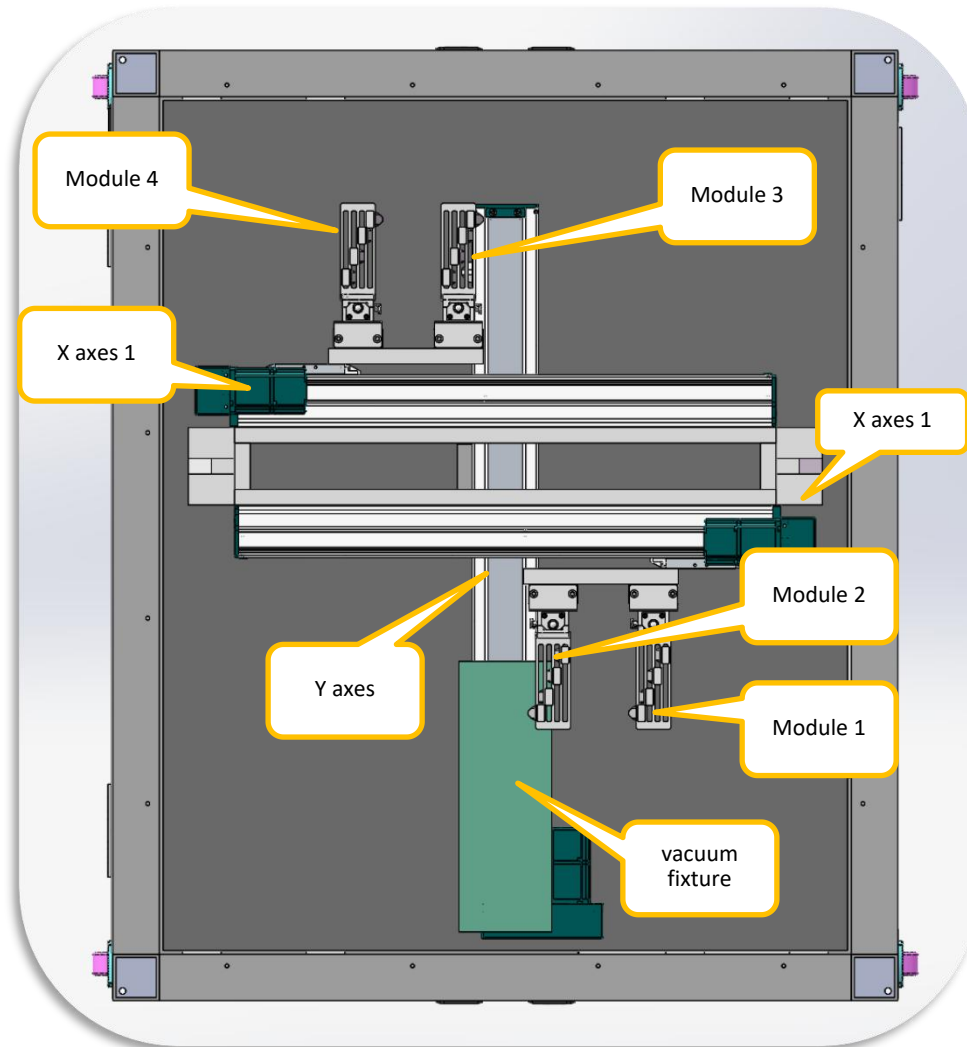

Lateral Flow Dispenser 20 pumps for 20 test lines

Overview

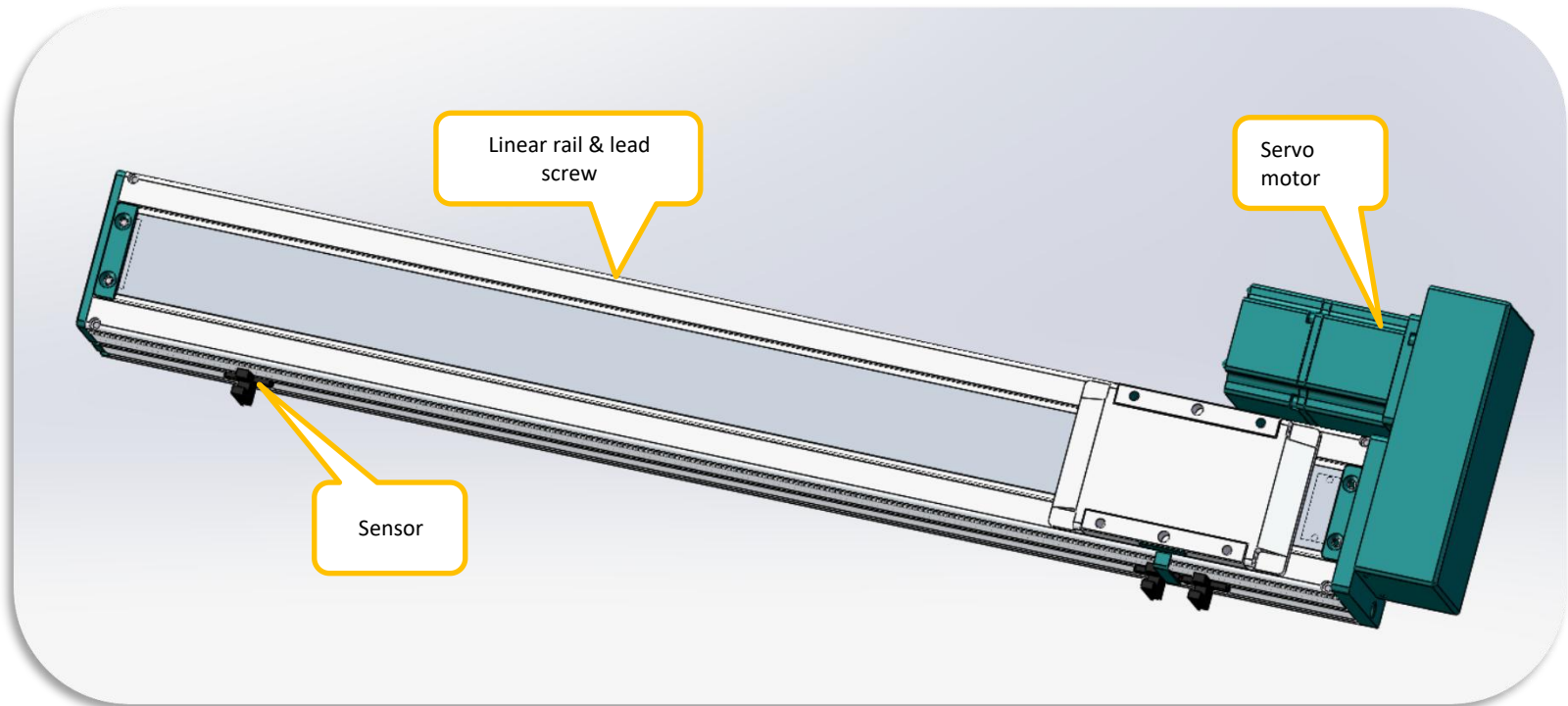

Lateral Flow Dispenser 20 pumps for 20 test lines

Overview

