

Pouch Packing Machine For Rapid Test Kit Manufacturing

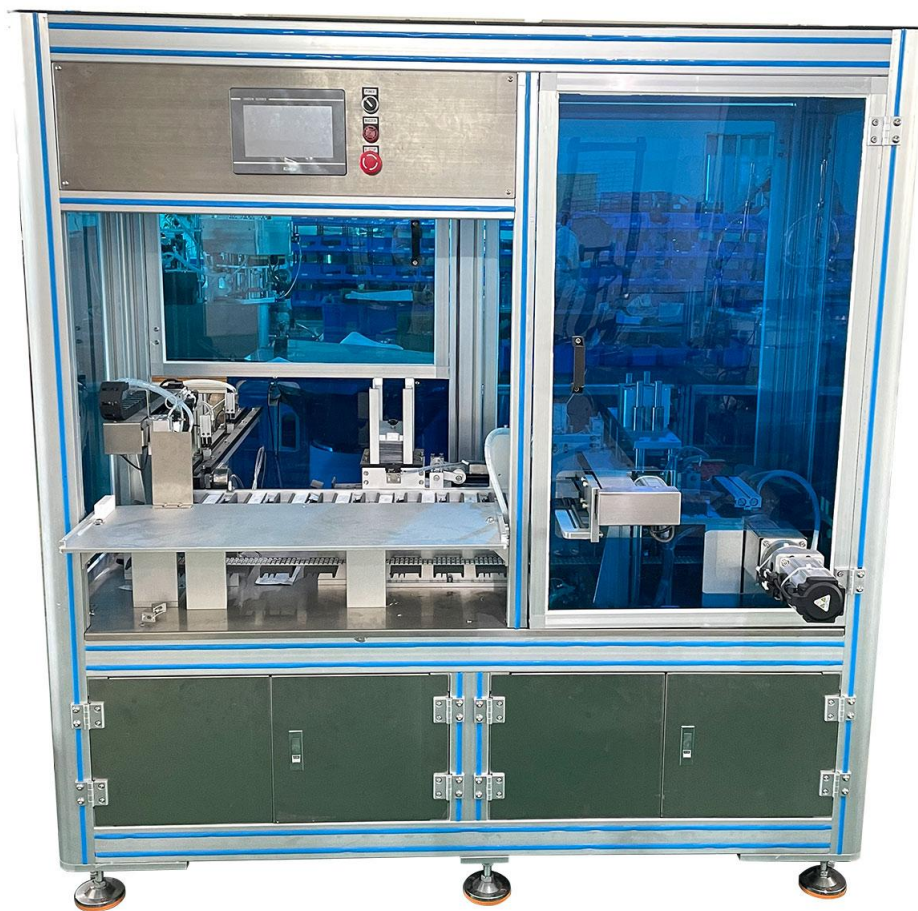

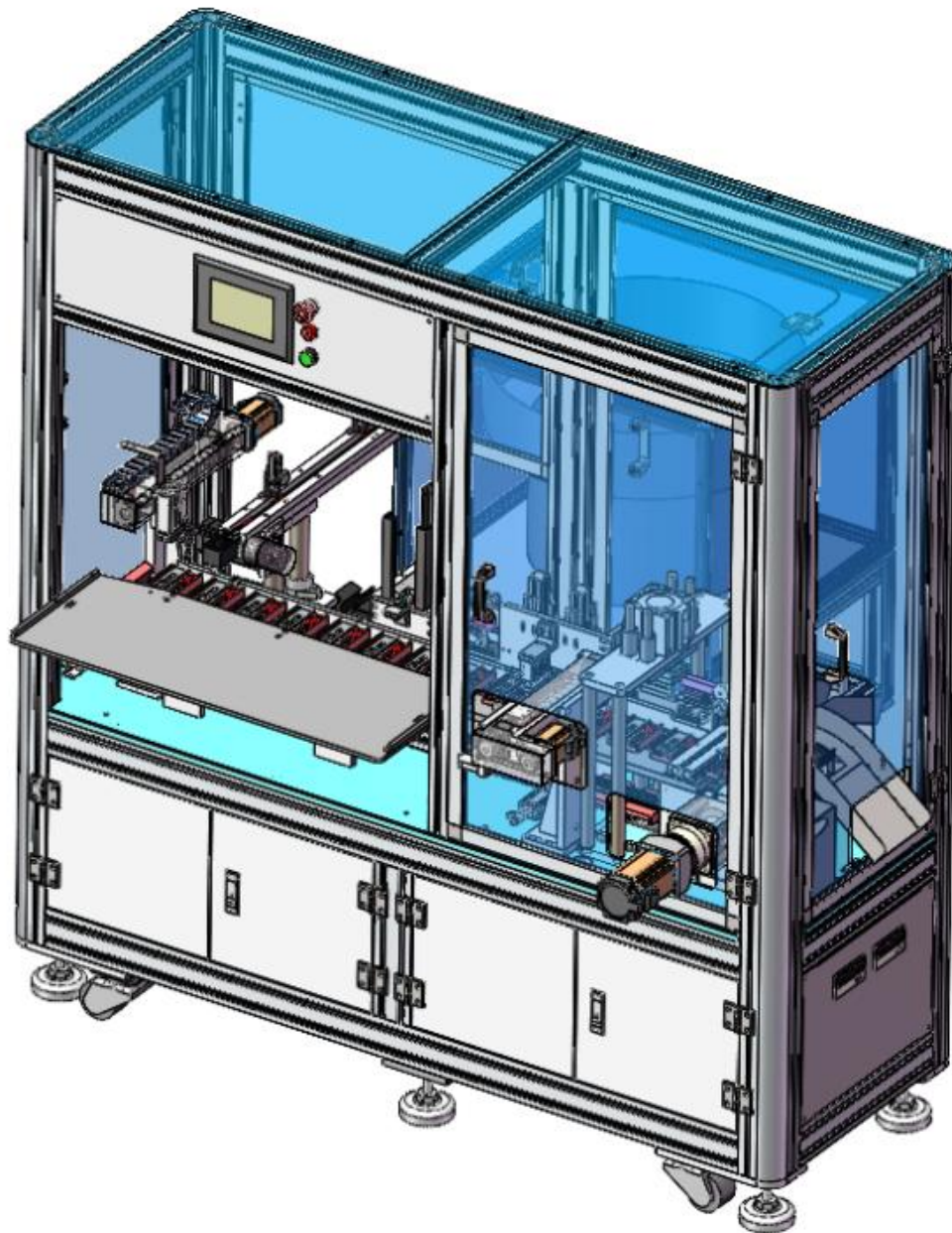

Workflow:

- 1 Automatic feeding desiccant
- 2 Manual feeding cassette & dropper
- 3 Automatic feeding bags
- 4 Automatic open bag
- 5 Automatic push cassette & dropper into bag
- 6 Testing thickness to check if cassette or desiccant missing (NG product)
- 7 Automatic remove NG bag
- 8 Finish product output

Workstations

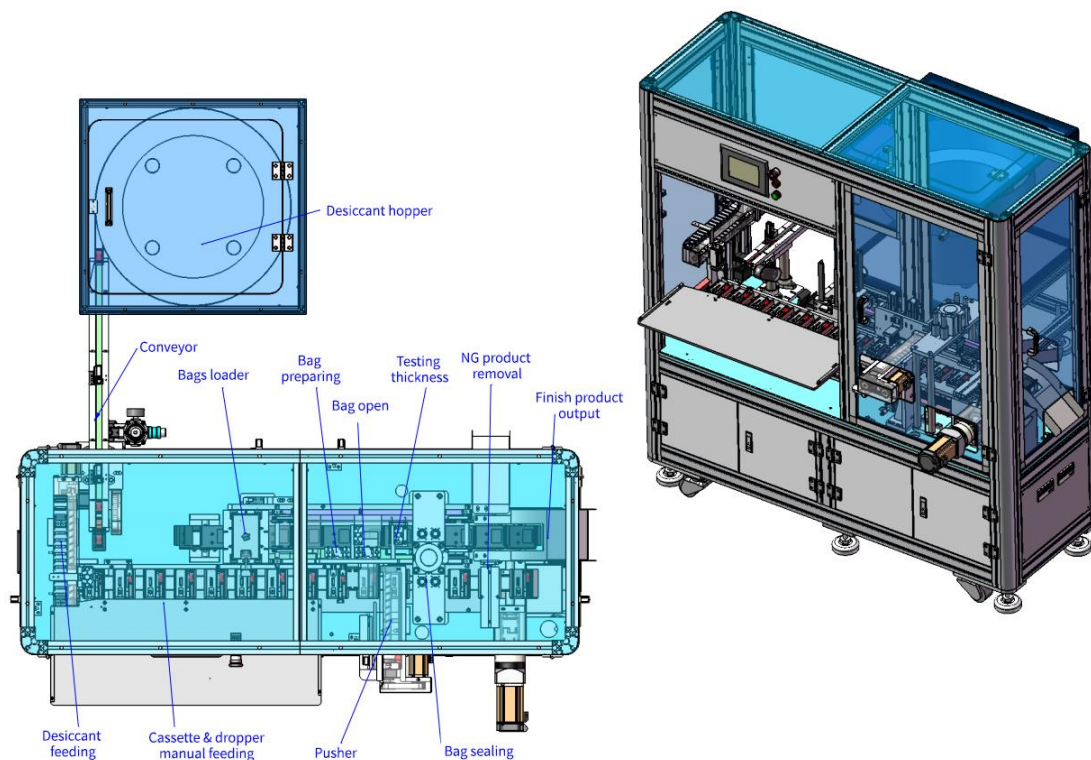

Specification

Capacity	1200pcs/hour	Power supply	220V
Air supply	0.6Mpa	Power	1200W
Weight	120kg	Dimension(L*W*H)	1.9*1.3*1.8m

Key components

1	PLC	XINJE	CHINA
2	Fiber sensor Photoelectric sensor	Panasonic/OMRON	Japan/German
3	24V power	Miwei	CHINA TAIWAN
4	Touch screen	Kinco/XINJE	CHINA
6	Leakage relay	CHNT/DELIXI	CHINA
7	Solenoid valve	Airtac	CHINA TAIWAN
8	Solid State Sensor	Airtac	CHINA TAIWAN
9	Cylinder	Airtac	CHINA TAIWAN
10	Pressure regulating valve	Airtac/XINGCHEN	CHINA TAIWAN

Video: <https://youtu.be/E03h2quF5Oo>