

Rapid Test Strip Packaging Machine

Cassette + desiccant + normal foil bag

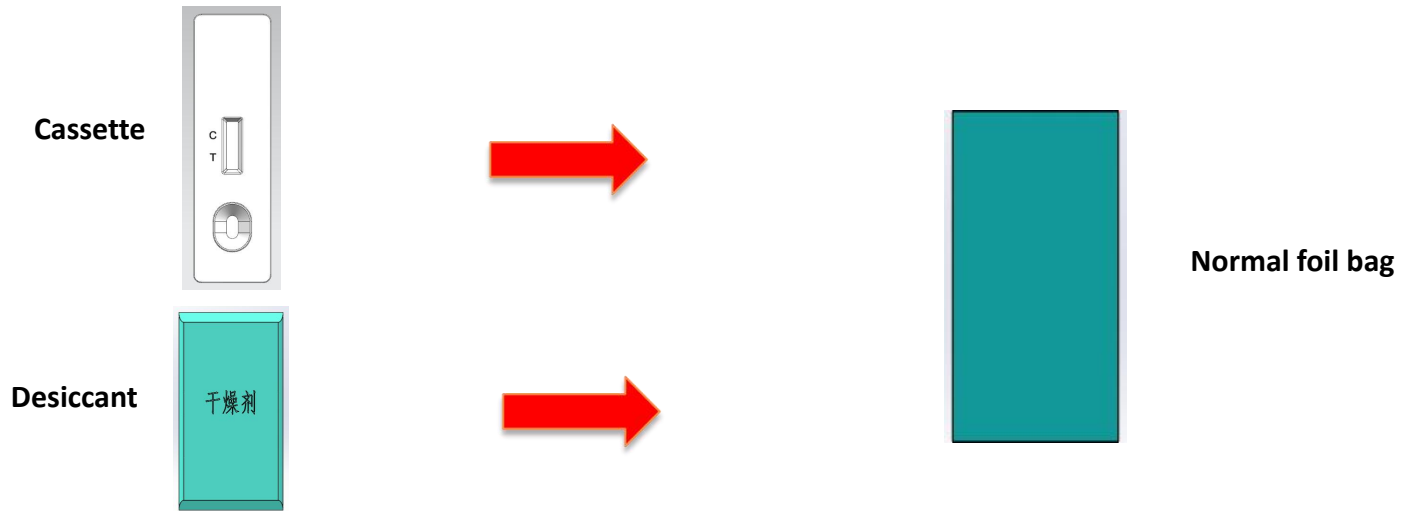

Workflow:

1. Automatic feeding foil bag
2. Manual feeding cassette
3. Automatic feeding desiccant bag
4. Automatic open foil bag
5. Automatic insert cassette and desiccant into foil bag
6. Automatic seal foil bag
7. Finish

Rapid Test Strip Packaging Machine

Cassette + desiccant + normal foil bag

Overview



Font view

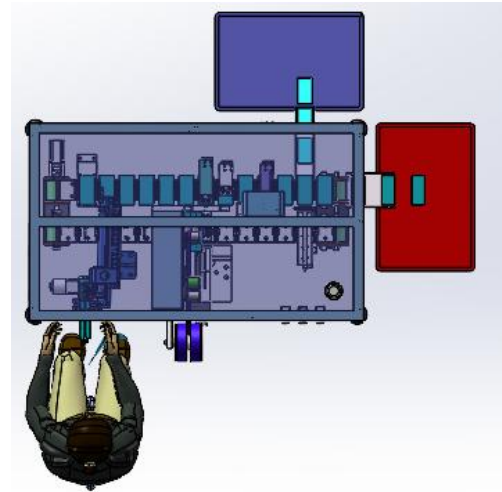

Top view

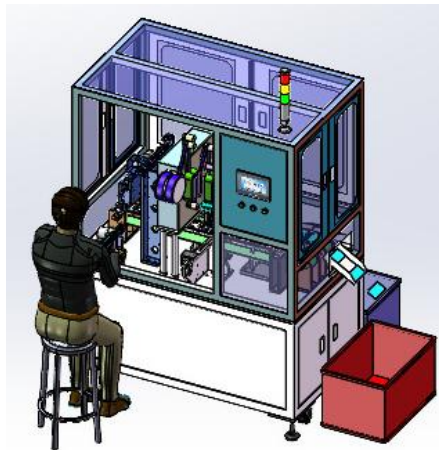

Side view

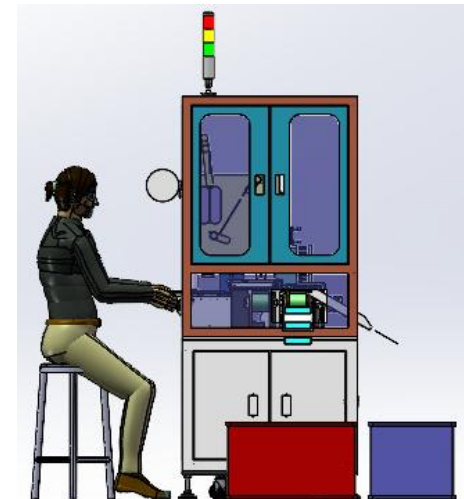

Right view

Rapid Test Strip Packaging Machine

Cassette + desiccant + normal foil bag

Dimension

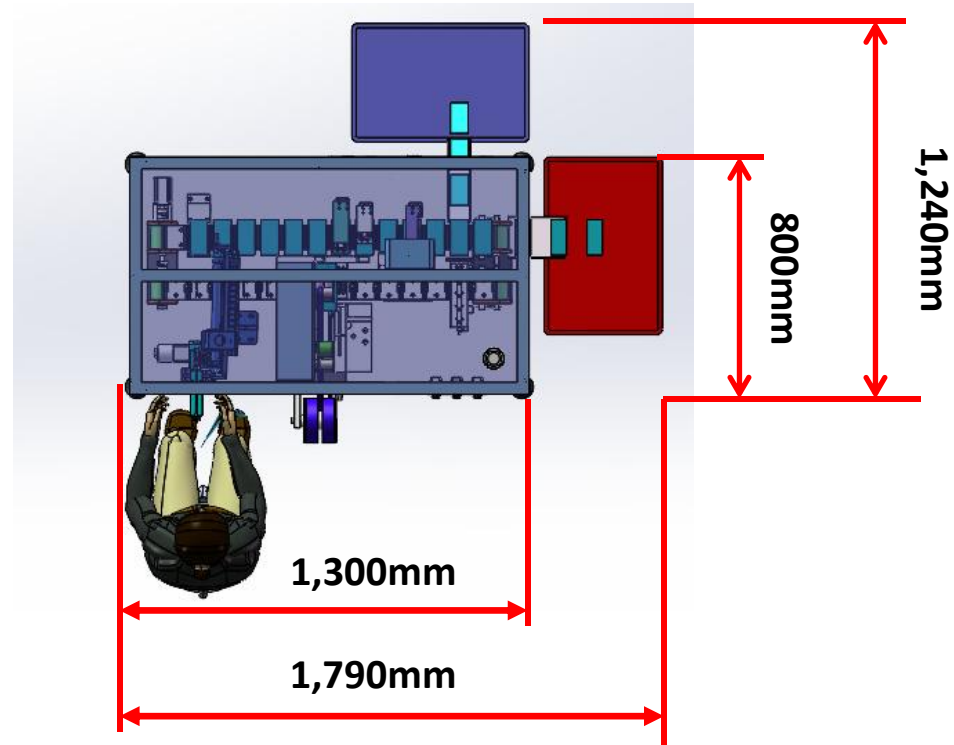

Rapid Test Strip Packaging Machine

Cassette + desiccant + normal foil bag

Workstations

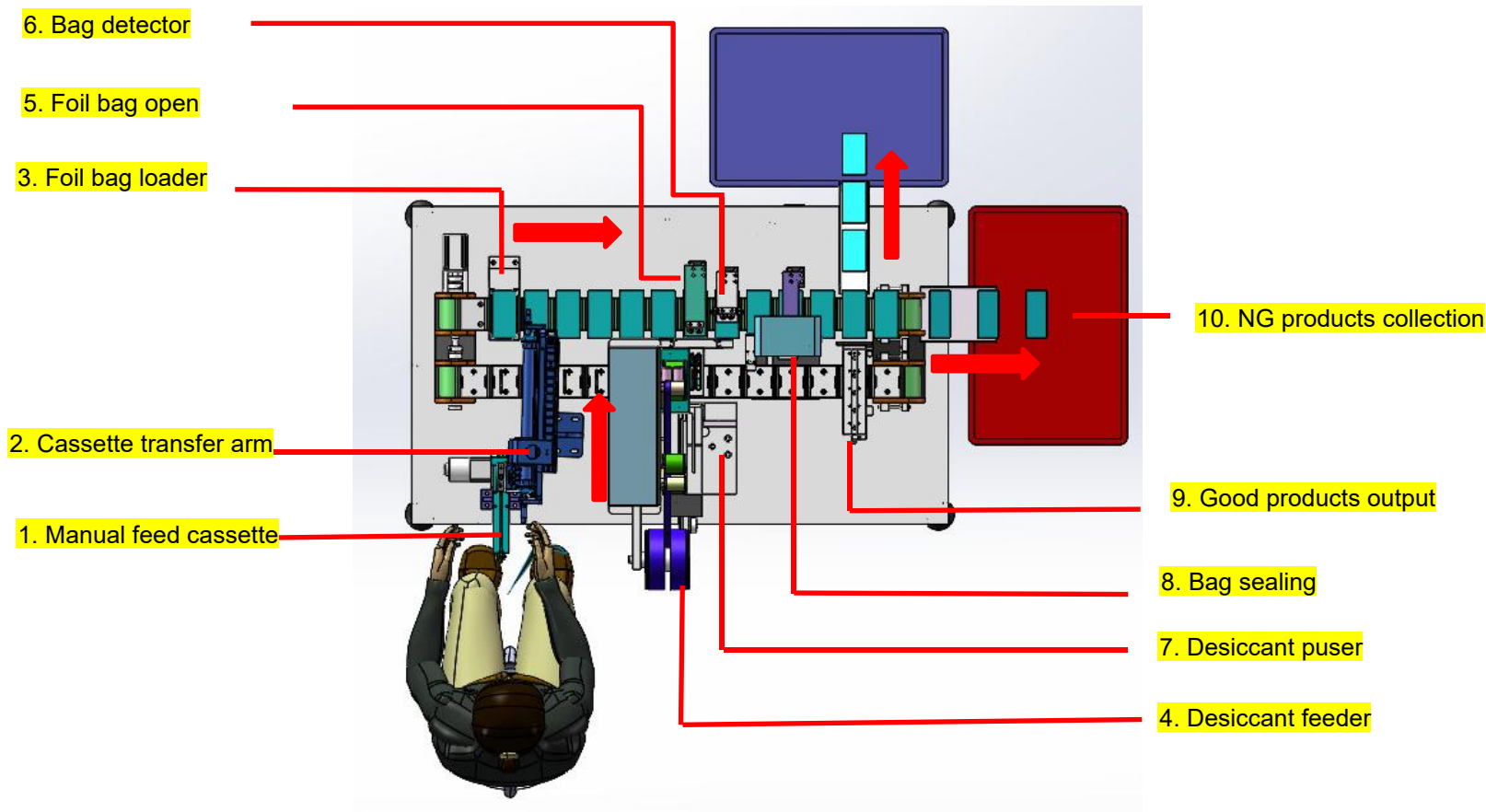

Rapid Test Strip Packaging Machine

Cassette + desiccant + normal foil bag

Manual cassette feeding

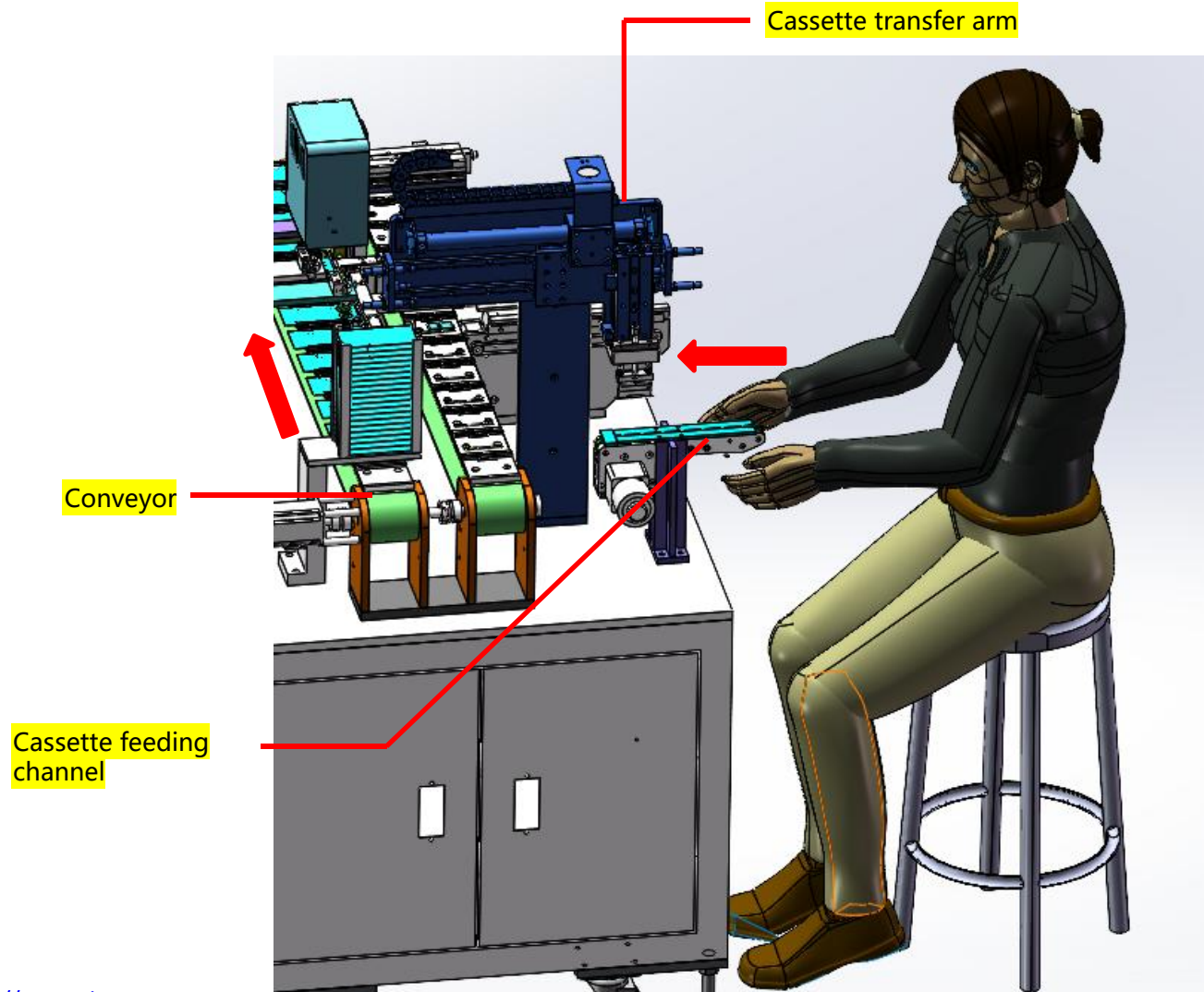

Rapid Test Strip Packaging Machine

Cassette + desiccant + normal foil bag

Foil bag feeding

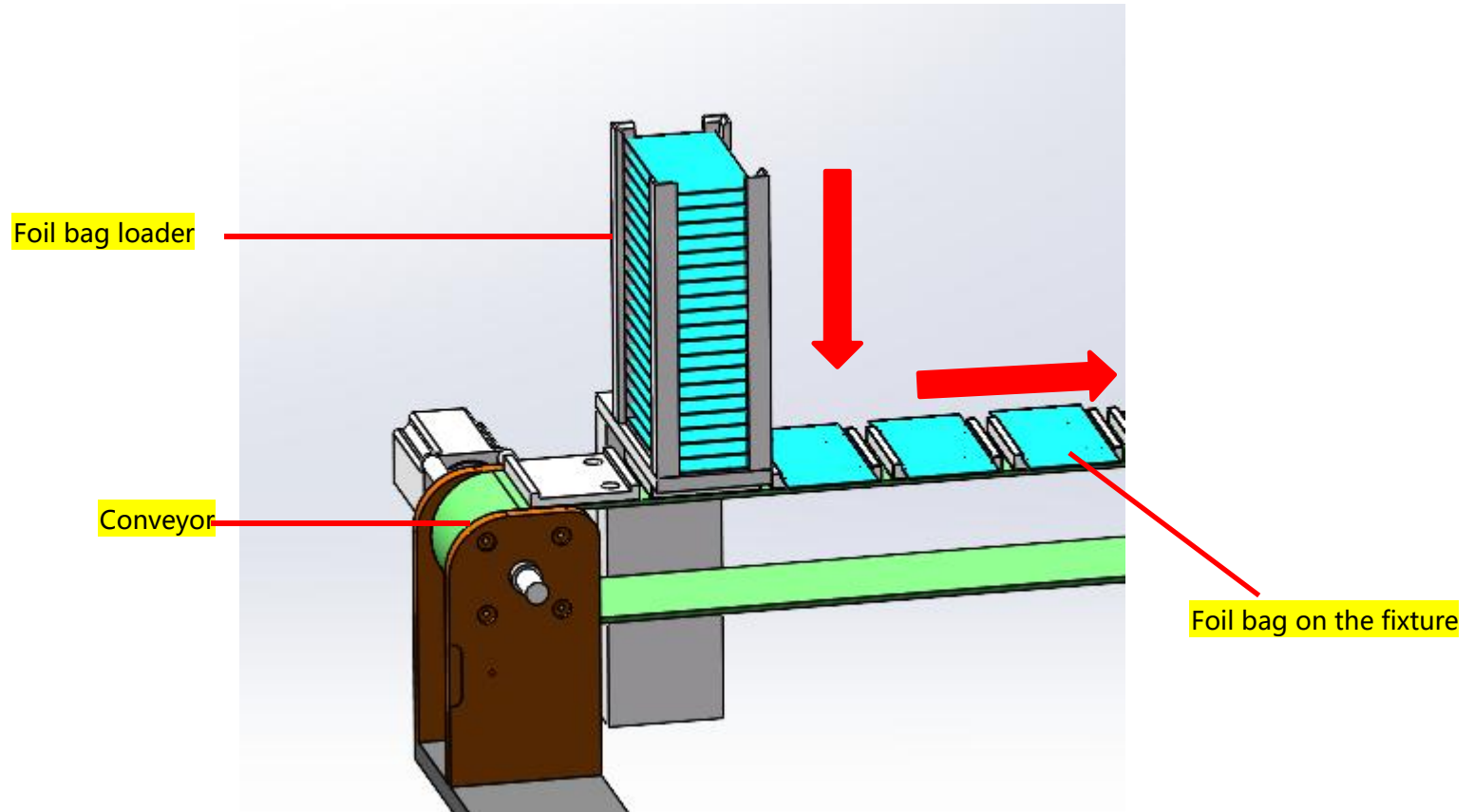

Rapid Test Strip Packaging Machine

Cassette + desiccant + normal foil bag

Desiccant feeder

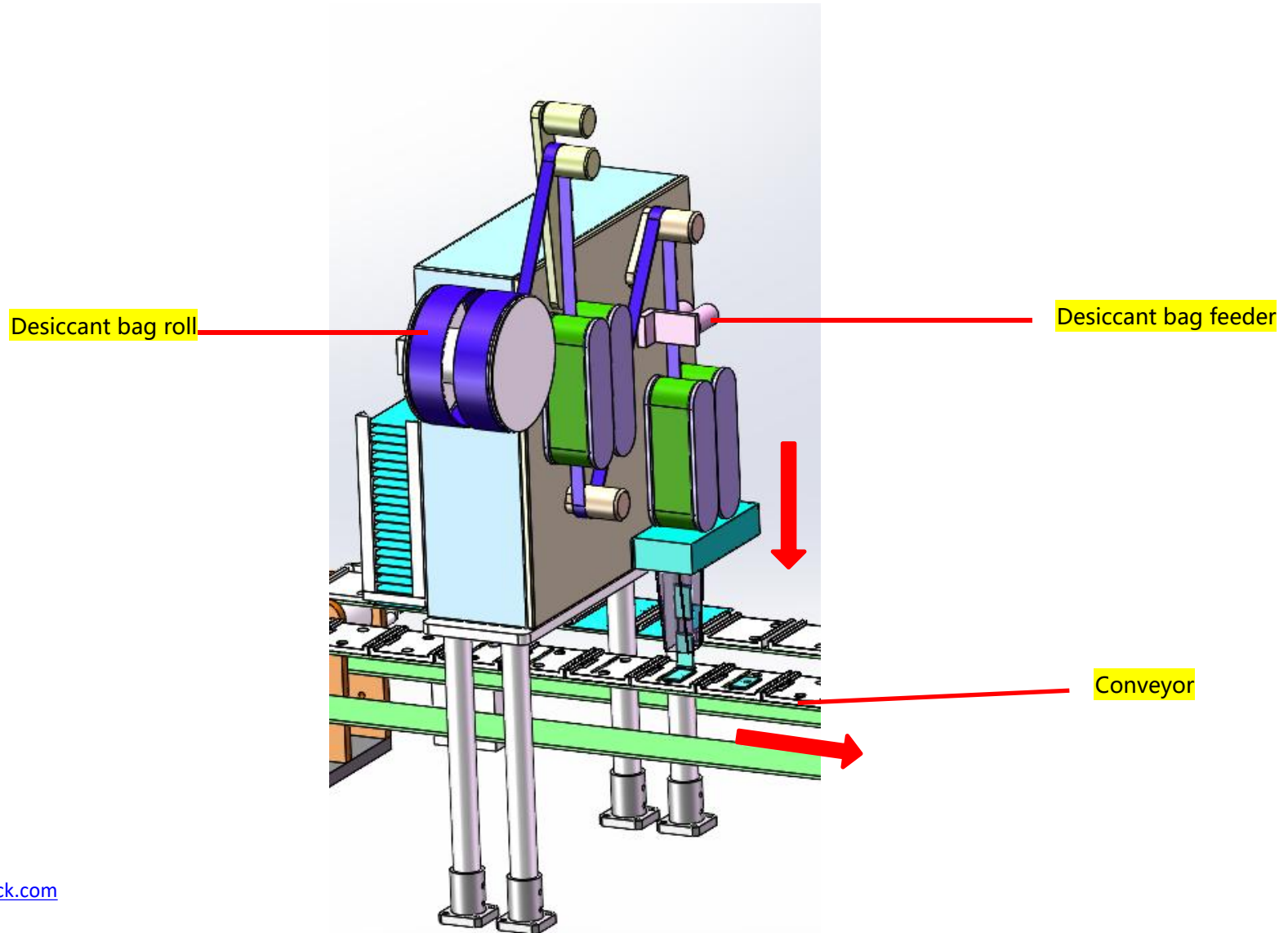

Rapid Test Strip Packaging Machine

Cassette + desiccant + normal foil bag

Desiccant insert into foil bag

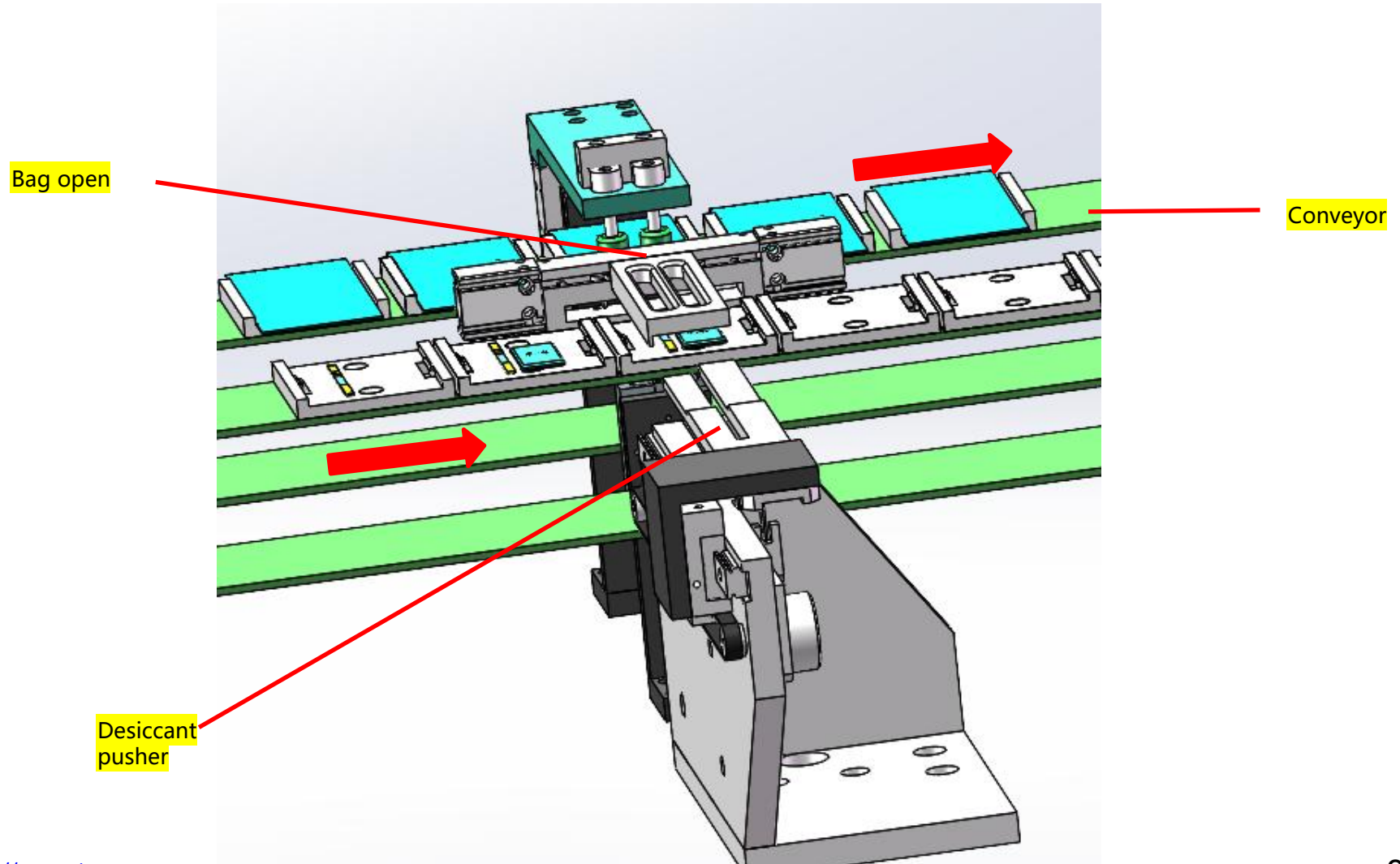

Rapid Test Strip Packaging Machine

Cassette + desiccant + normal foil bag

Foil bag sealing

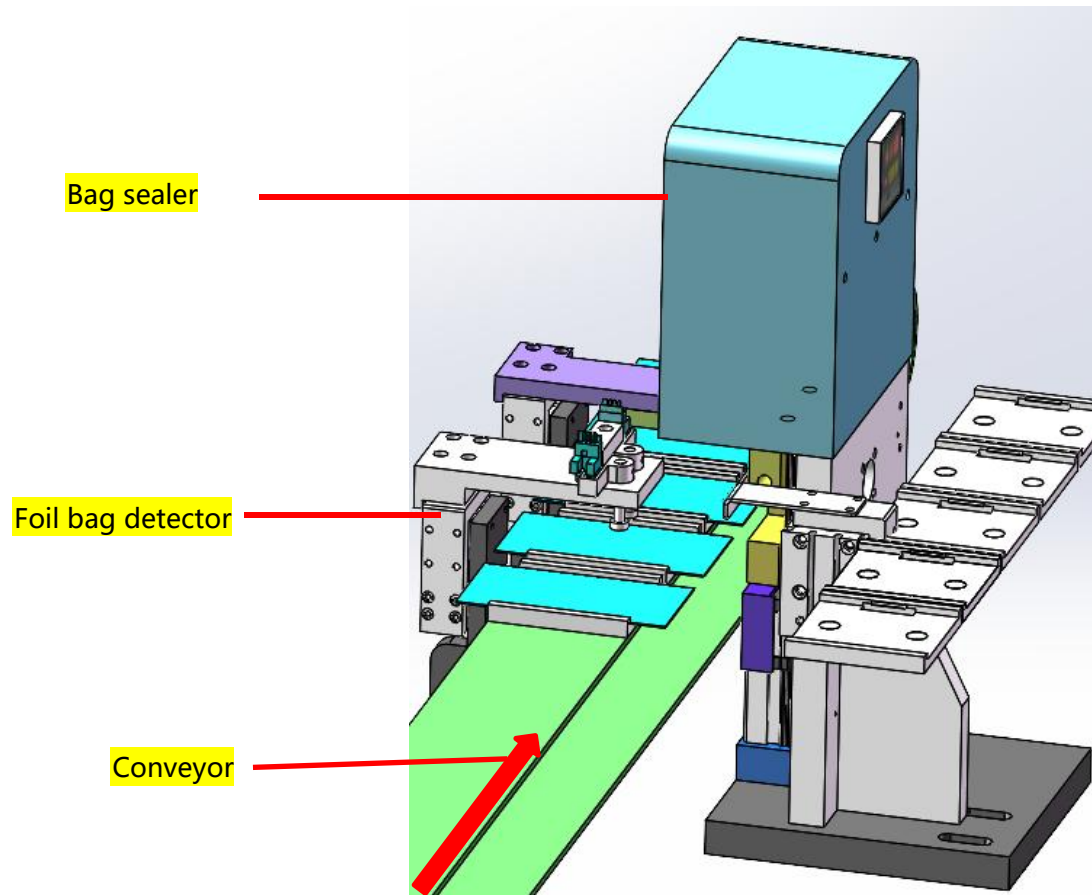

Rapid Test Strip Packaging Machine

Cassette + desiccant + normal foil bag

Output

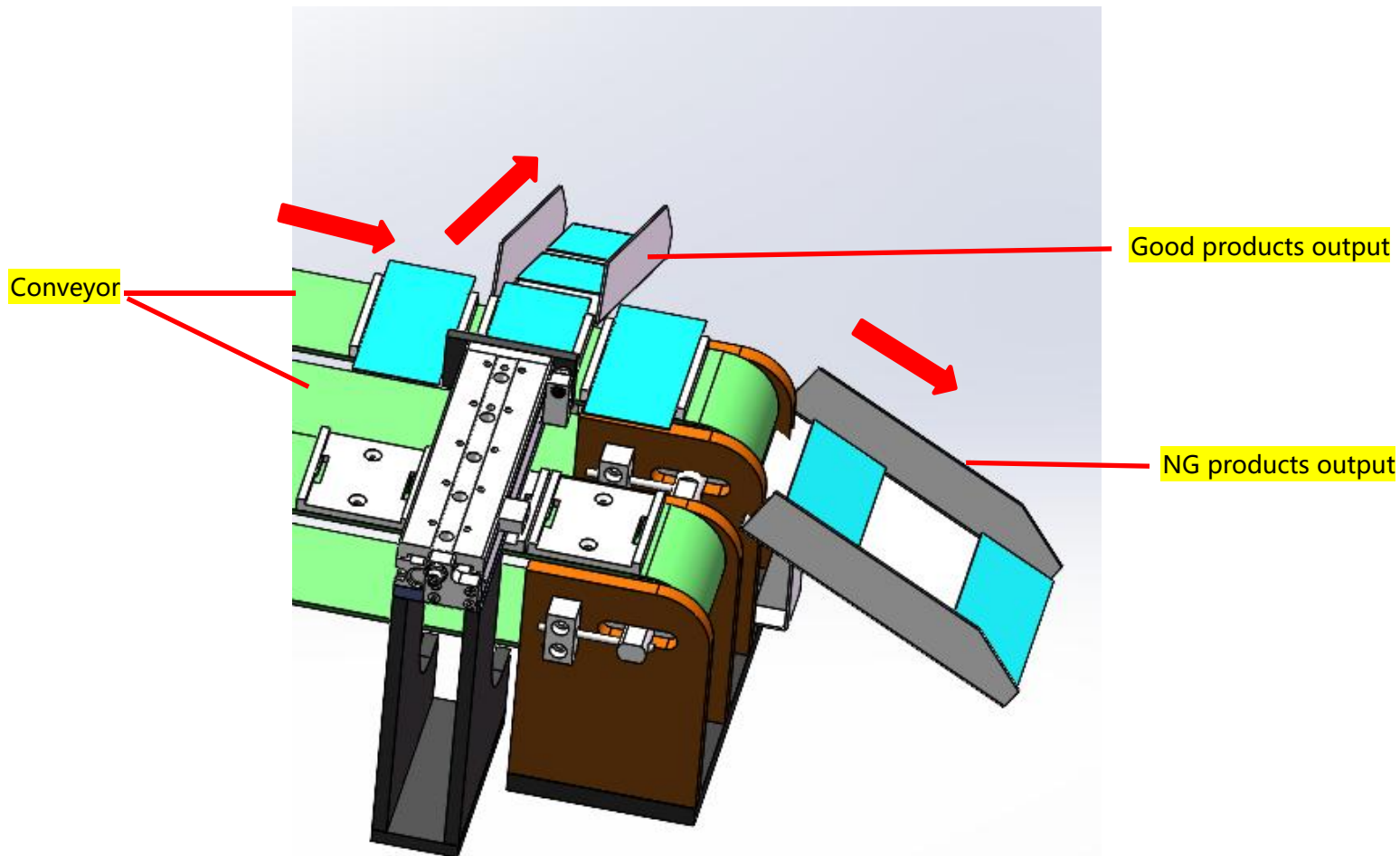

Rapid Test Strip Packaging Machine

Cassette + desiccant + normal foil bag

Features

1. English menu
2. Capacity: 1,500bags/hour
3. Easy for run and maintenance

Operation

1. Connect with power supply and air supply
2. Put foil bag into loader
3. Install desiccant bag roll
4. Start machine
5. Manual feed cassette
6. Keep running

Rapid Test Strip Packaging Machine

Cassette + desiccant + normal foil bag

Parameters	
Capacity	1,500pcs/Hour
Activation	90%
Air supply	0.5~0.8MPa
Power supply	AC220V/50Hz
Internal power	DC/24V
Power	13.0 KW
Weight	800kg
Dimension	L1.3 * W0.8 * H1.85m
Wooden packing	---

All data will be changable according to final design

Rapid Test Strip Packaging Machine

Cassette + desiccant + normal foil bag

Key components	
PLC	Mitsubishi/Panasonic/other
Operation system	ANTITECK
Servo	Inovance/KNK
Relay	Schneider/CHNT
Sensor	OMRON/Panasonic
Cylinder	SMC/AIRTAC
Solenoid valve	SMC/AIRTAC
Connector	SMC/AIRTAC

All data will be changable according to final design

What ANTITECK can do?

For automation product line

non-standard automatic machine

Communication

1. Customer provide details
2. Provide samples for machine design

Design

Start designing

Equipments manufacturing

In manufacturing process

Installation Commissioning

Deliver machine
Installation
Commissioning