

Rapid Test Kit Assembly Machine Multiple Strips In One Cassette

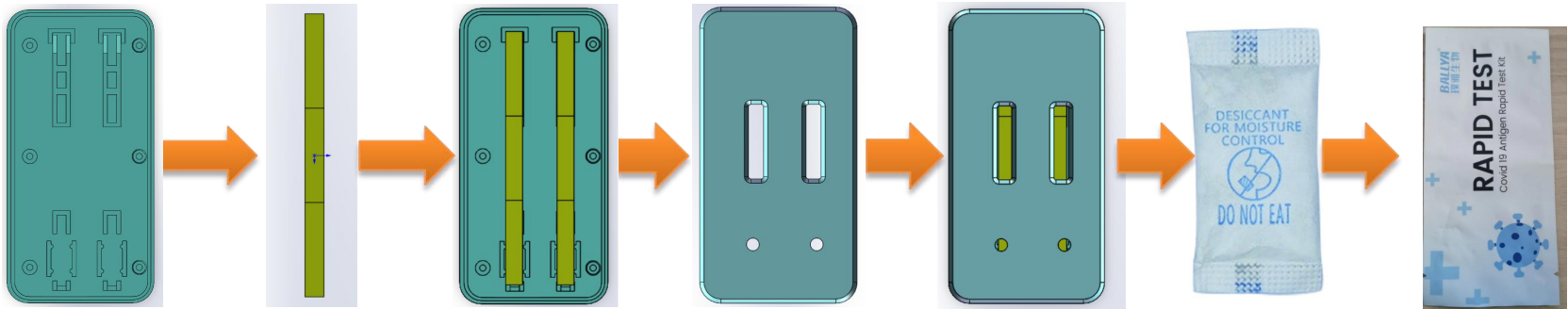

Work flow:

1. Cassette bottom feeding by conveyor (instead of bowl)
2. Cutter 1, remove NG strip, insert strip 1 into channel 1, CCD inspection
3. Cutter 2, remove NG strip, insert strip 2 into channel 2, CCD inspection
4. Cassette cover feeding by conveyor (instead of bowl)
5. Cassette pressing
6. Laser printing on cassette (text, logo, bar code, qr code, etc.)
7. Send to pouch packing machine
8. Foil bag feeding
9. Desiccant feeding (roll format)
10. Insert cassette and desiccant into foil bag
11. Sealing foil bag
12. Output

Rapid Test Kit Assembly Machine Multiple Strips In One Cassette

Uncut sheet & strip

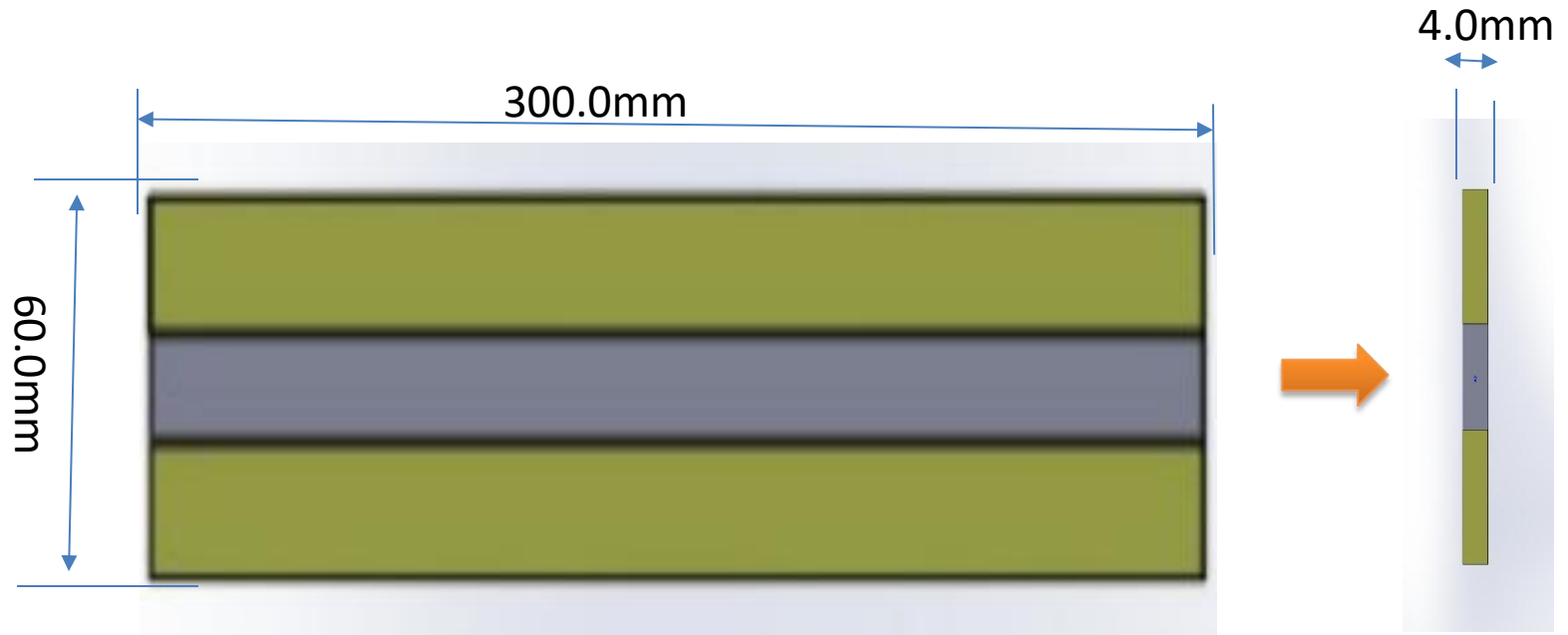

Rapid Test Kit Assembly Machine Multiple Strips In One Cassette

Dimension

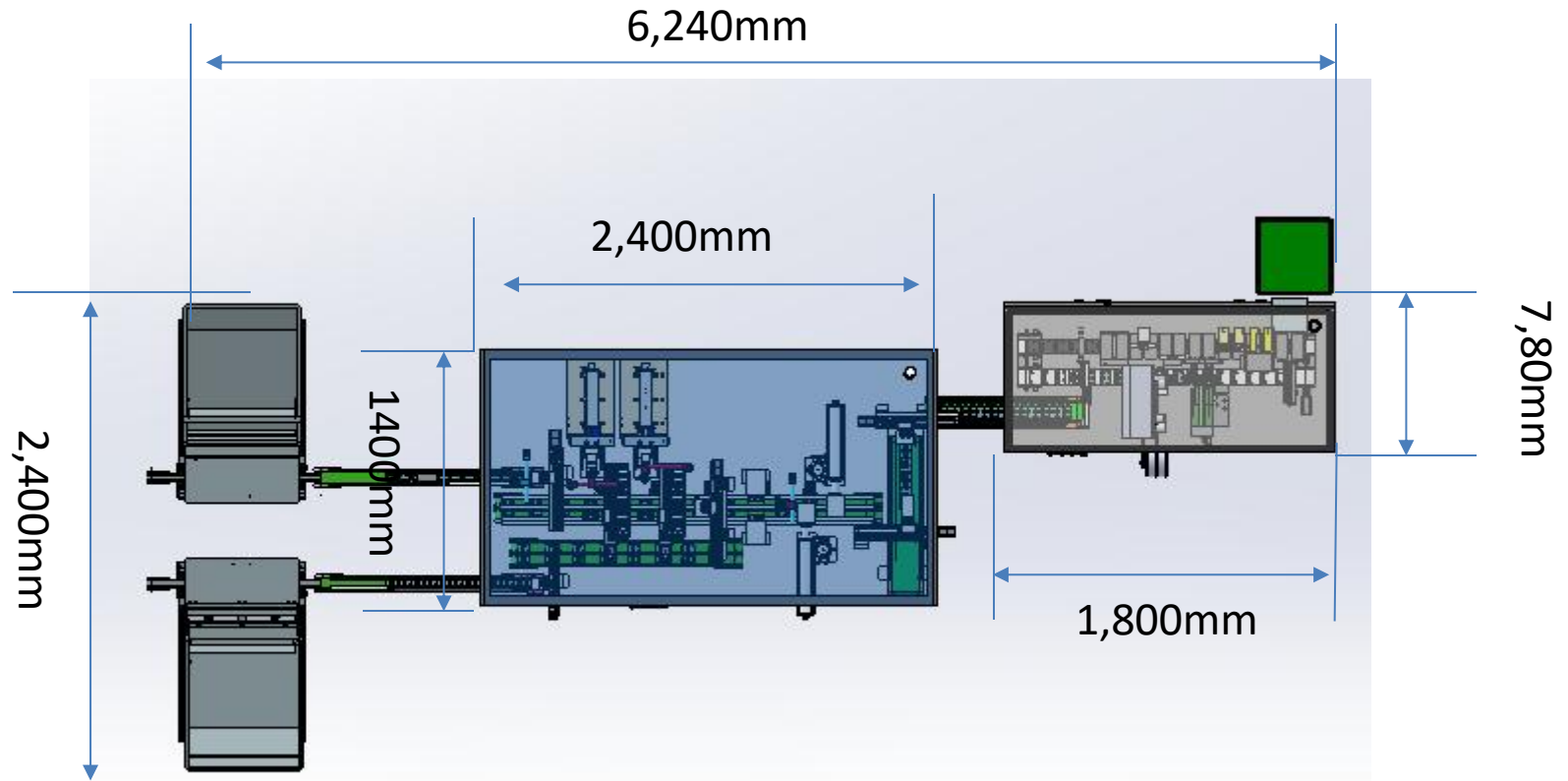

All data maybe changed according to final design

Rapid Test Kit Assembly Machine

Multiple Strips In One Cassette

Overview

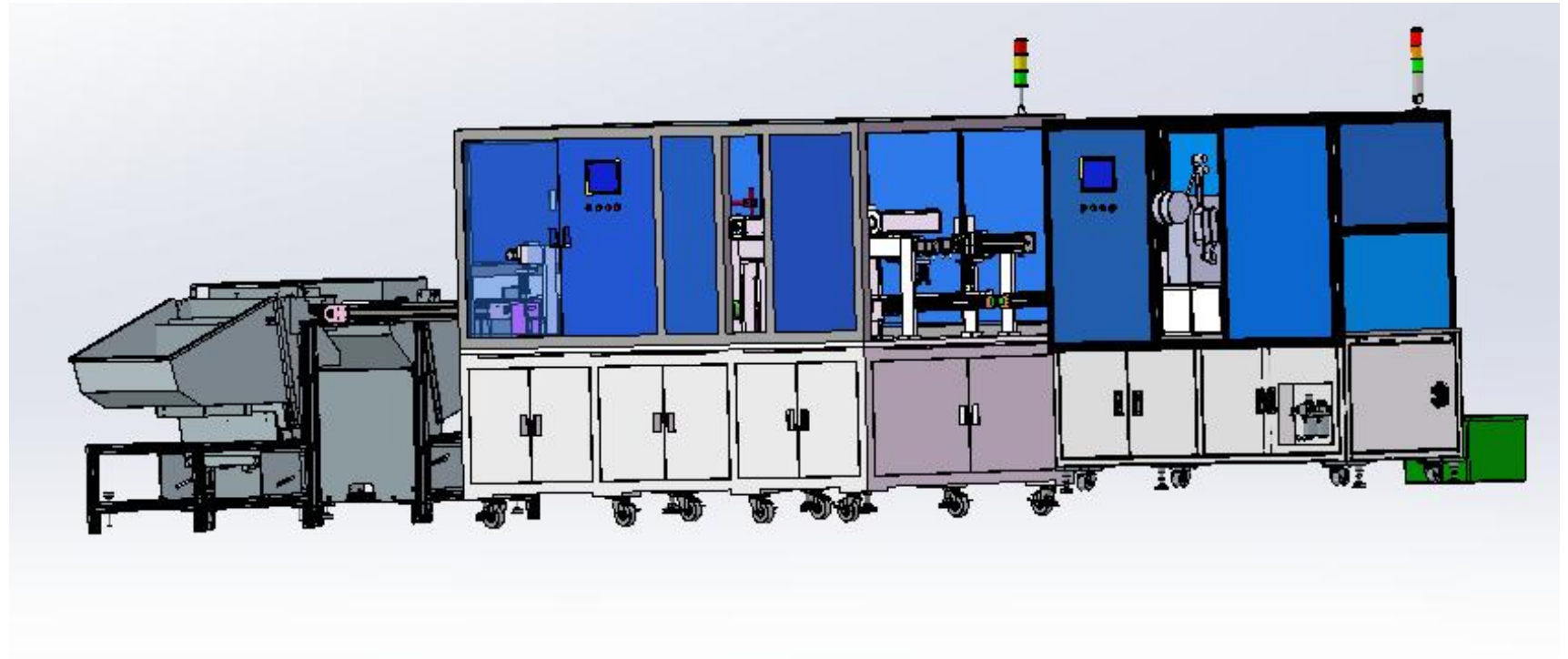

Rapid Test Kit Assembly Machine

Multiple Strips In One Cassette

Overview

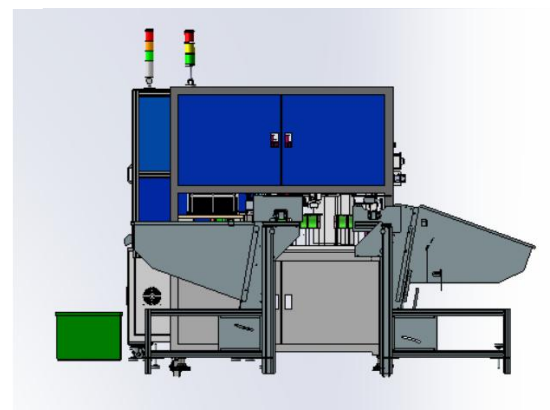
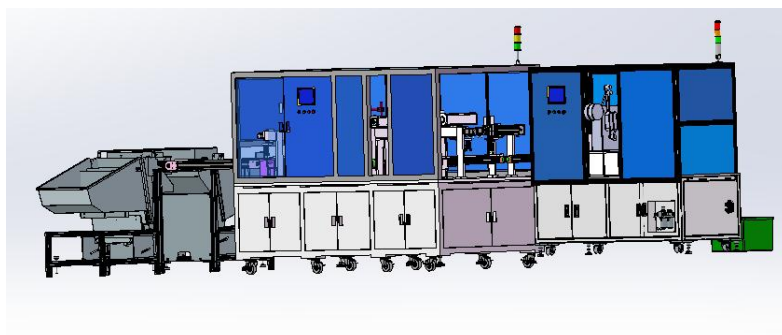
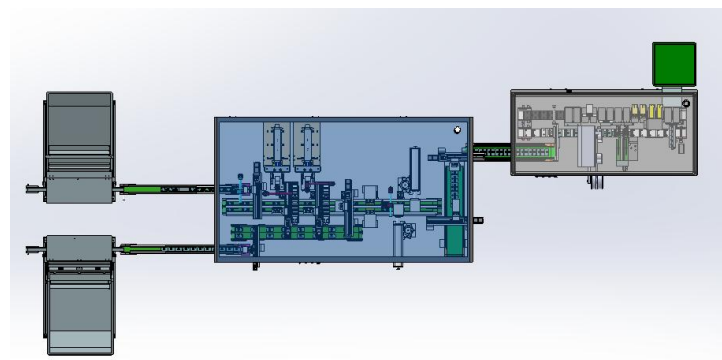
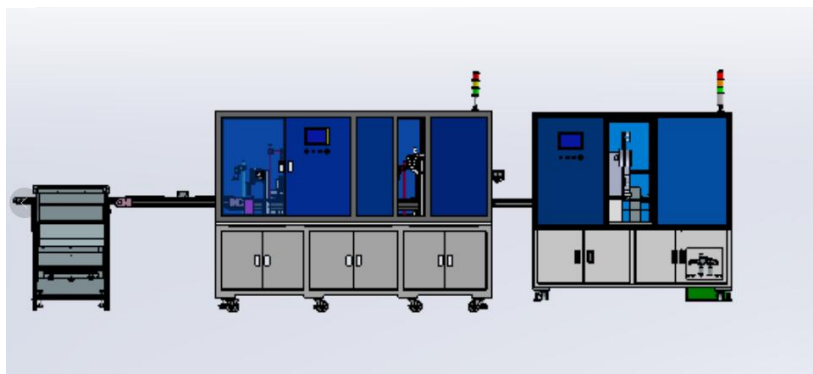

Rapid Test Kit Assembly Machine

Multiple Strips In One Cassette

Rapid Test Assembly Machine

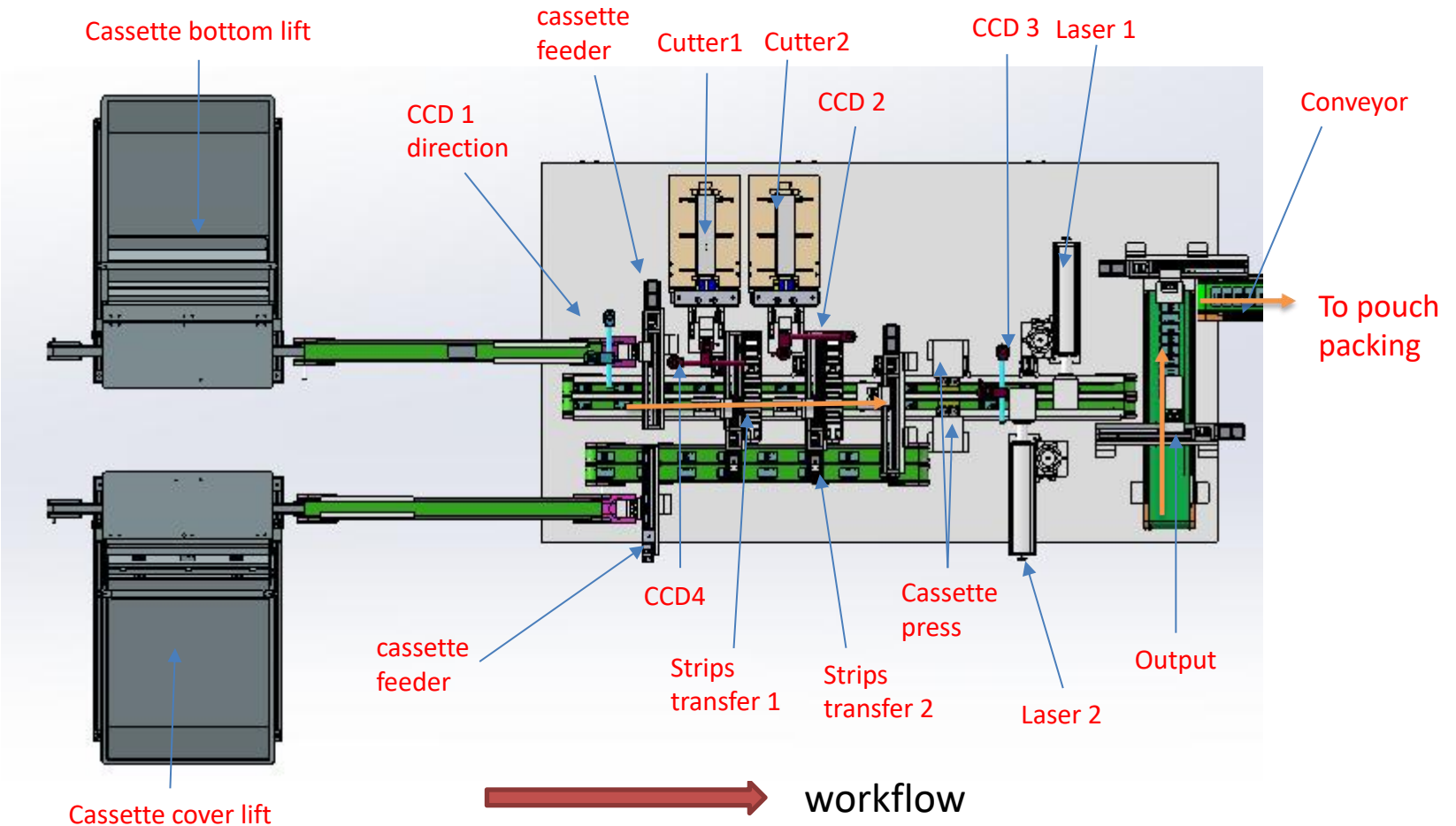

Rapid Test Kit Assembly Machine

Multiple Strips In One Cassette

Pouch packing machine

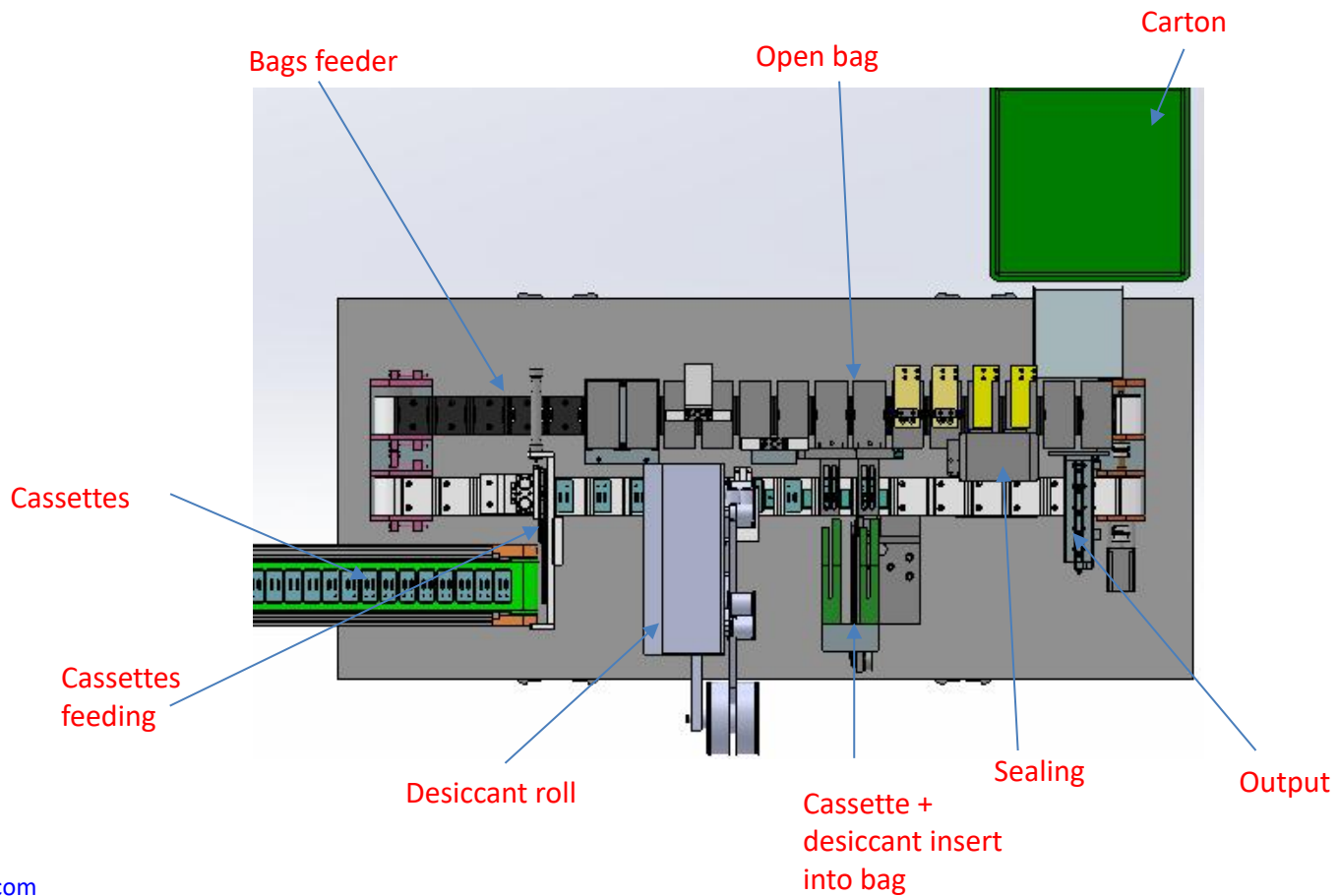

Rapid Test Kit Assembly Machine

Multiple Strips In One Cassette

Cassette feeding

Cassette bottom lift

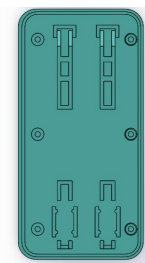
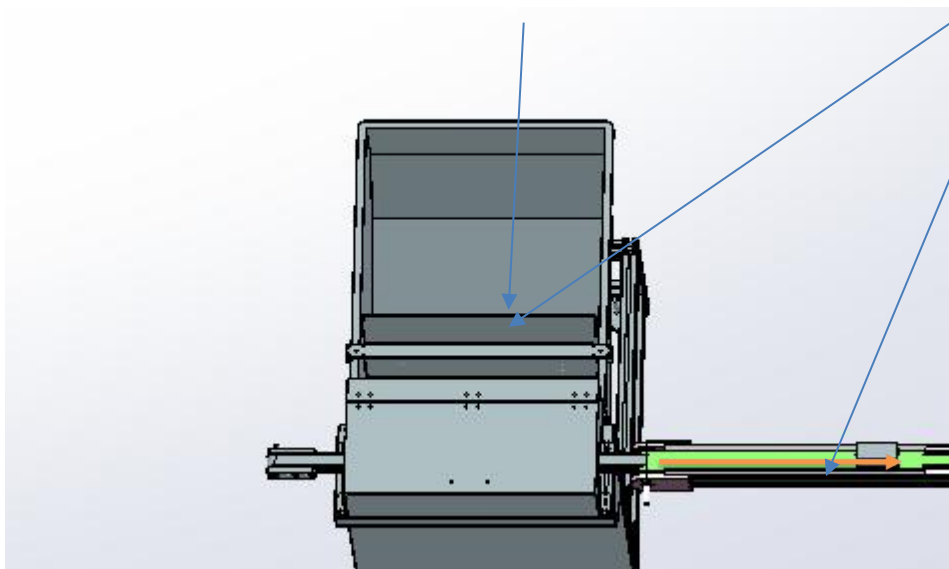

Conveyor

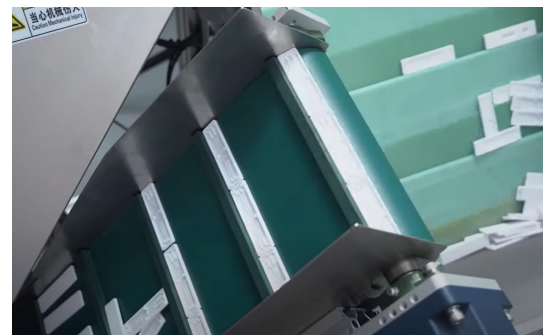

Rapid Test Kit Assembly Machine Multiple Strips In One Cassette

Cassette feeding

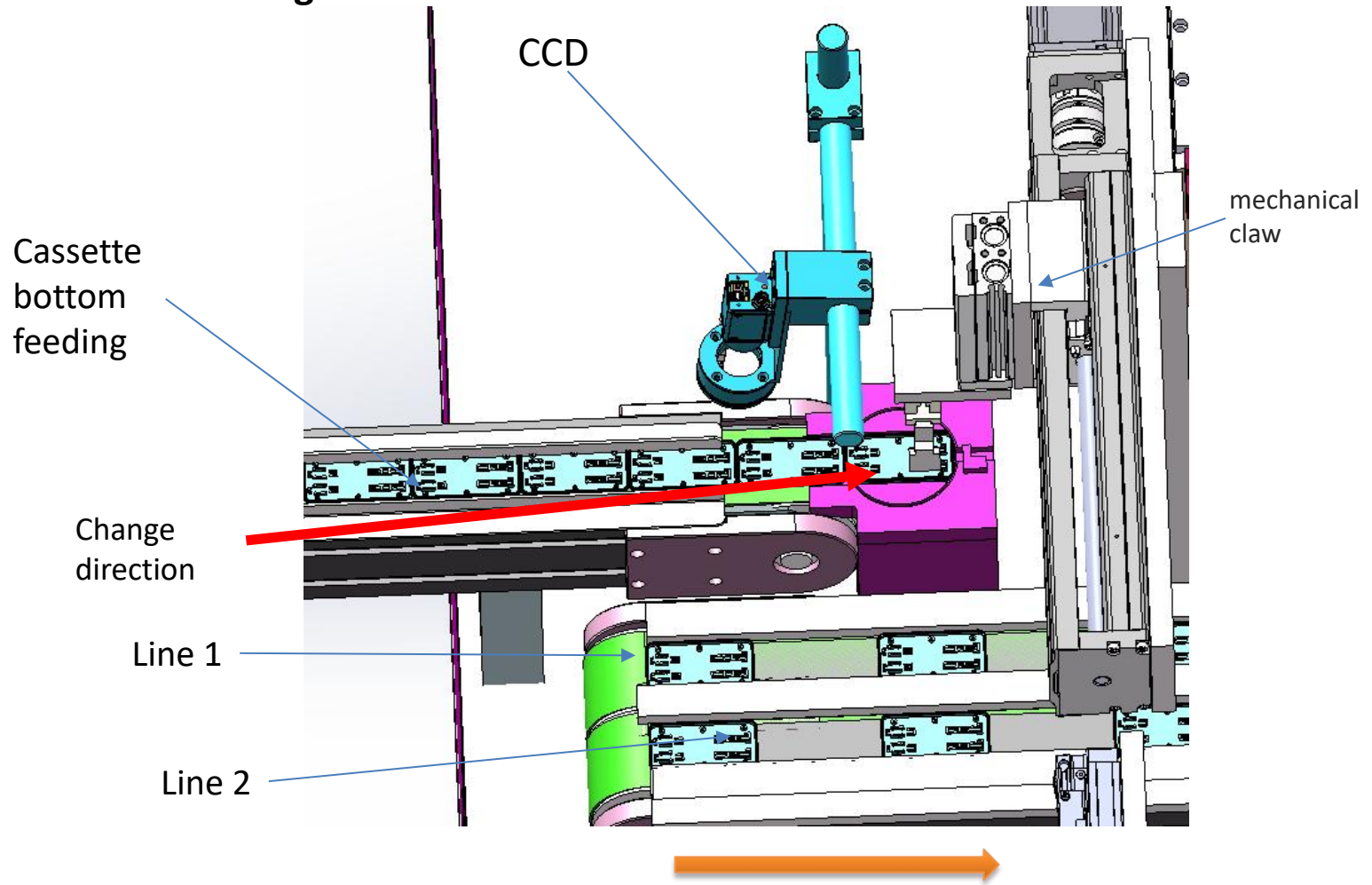

Rapid Test Kit Assembly Machine

Multiple Strips In One Cassette

Cutter 1

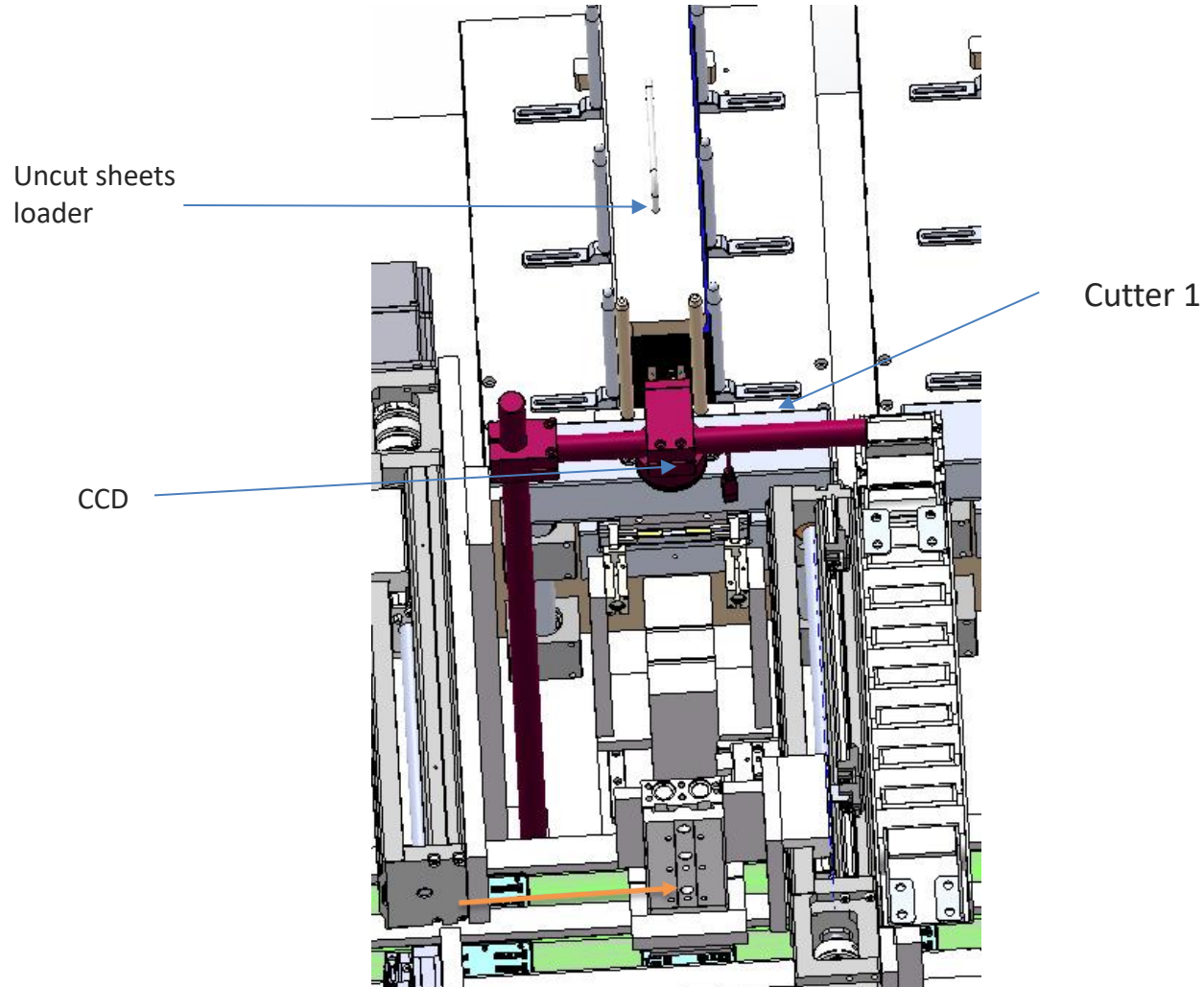

Rapid Test Kit Assembly Machine Multiple Strips In One Cassette

Cutter 2

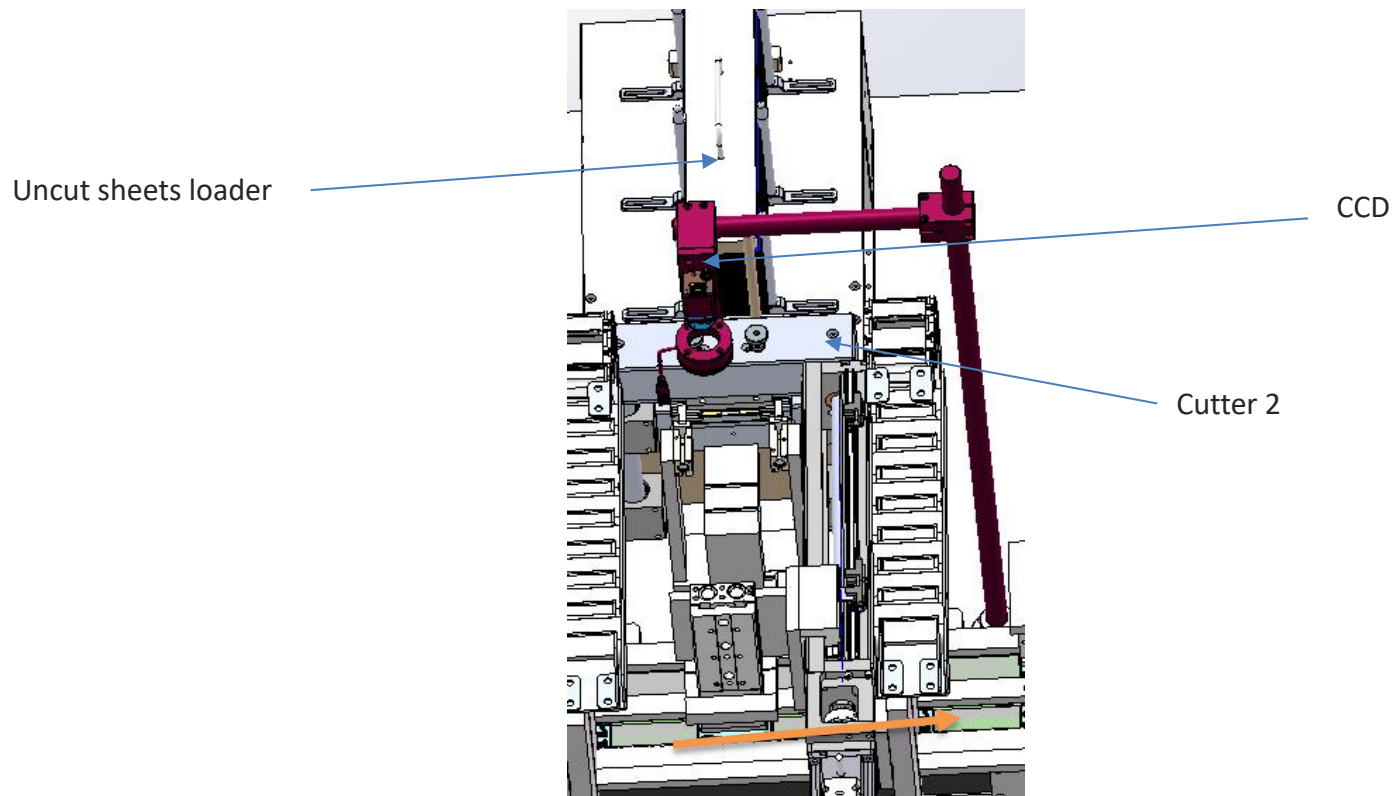

Rapid Test Kit Assembly Machine Multiple Strips In One Cassette

Cassette feeding

Cassette bottom lift

Conveyor

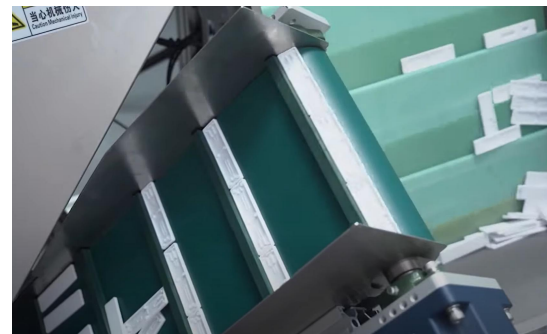
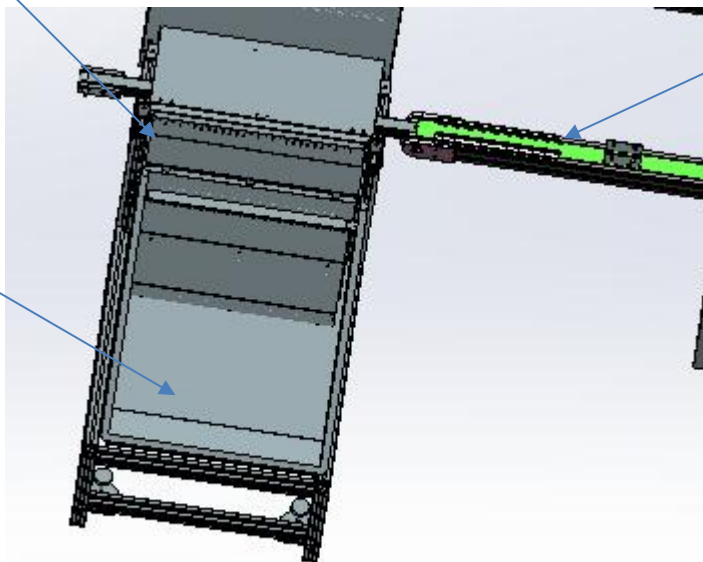
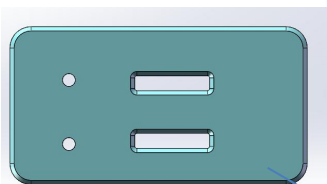

Rapid Test Kit Assembly Machine Multiple Strips In One Cassette

Cassette feeding

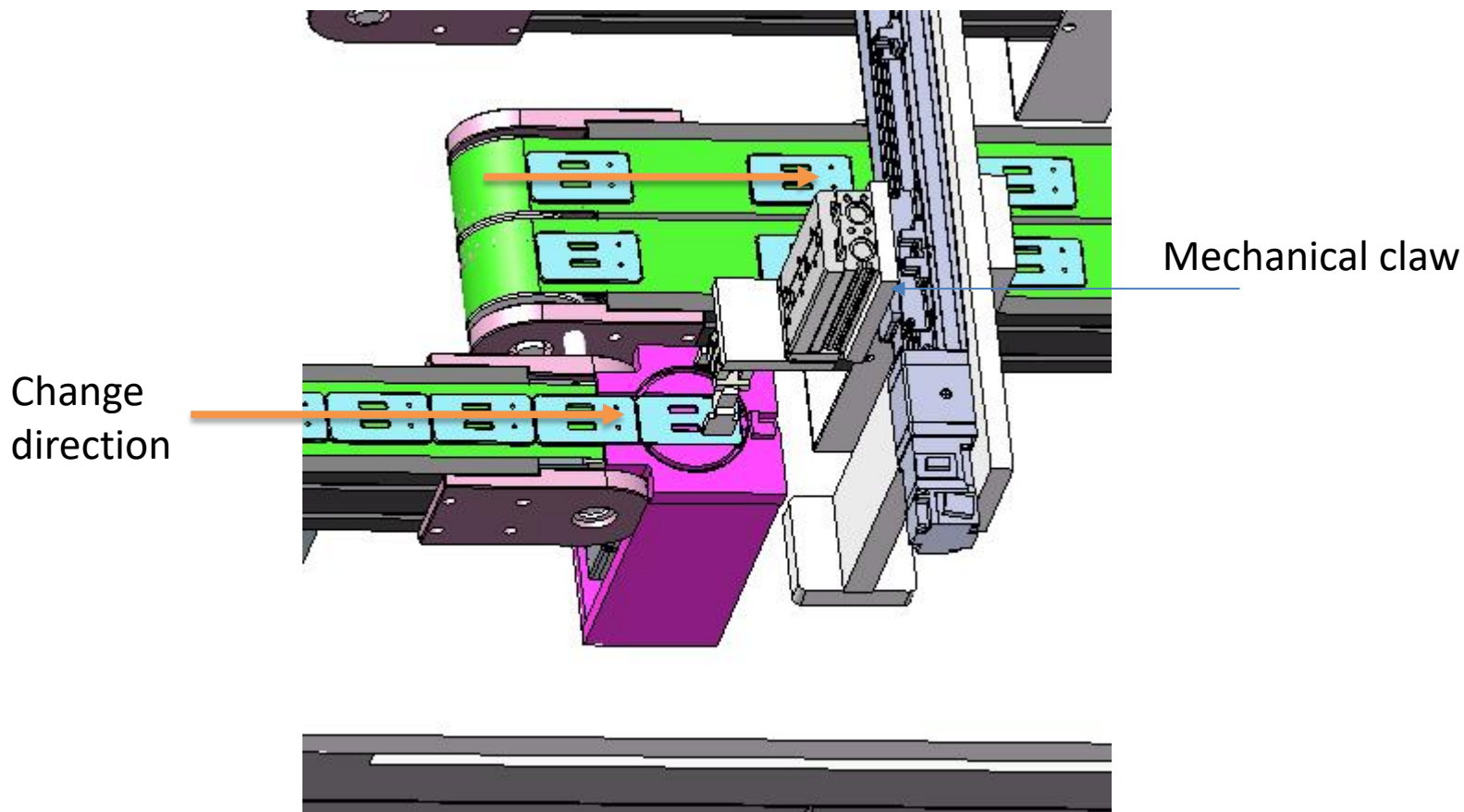

Rapid Test Kit Assembly Machine Multiple Strips In One Cassette

Cassettes pressing

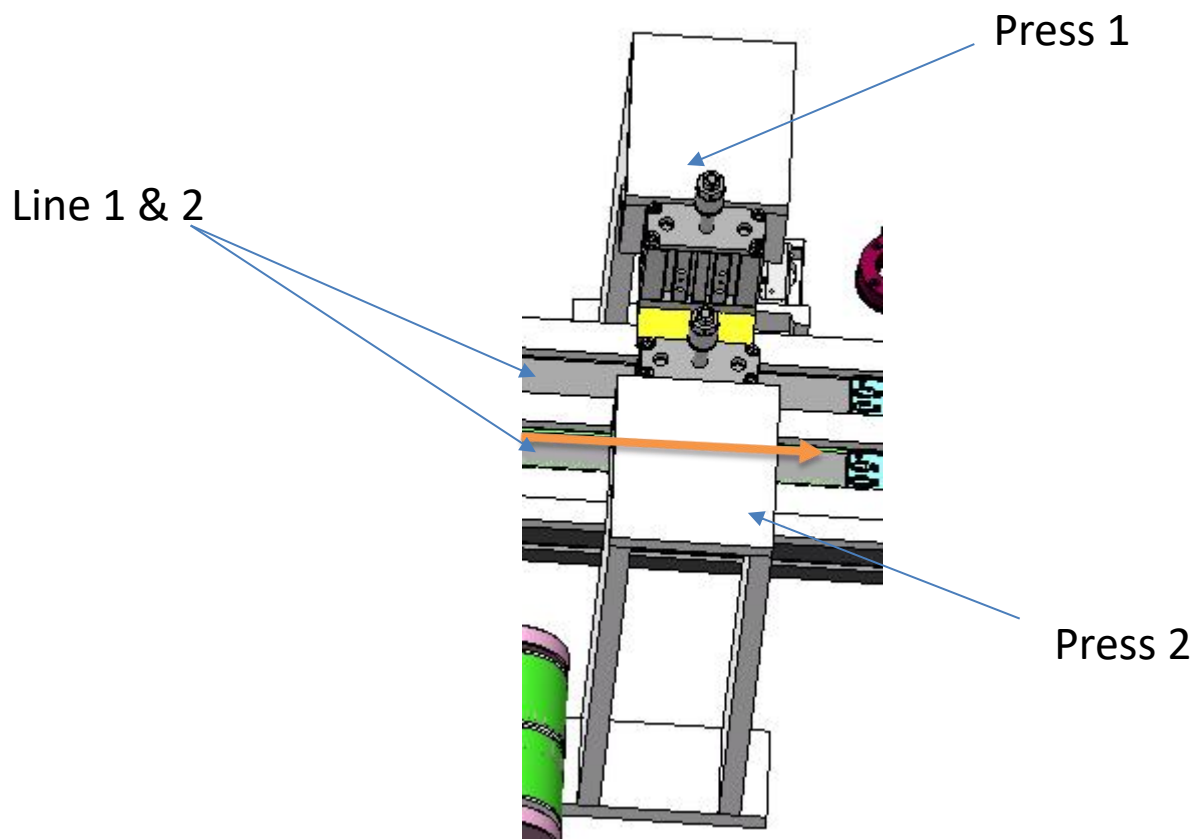

Rapid Test Kit Assembly Machine Multiple Strips In One Cassette

Laser printing

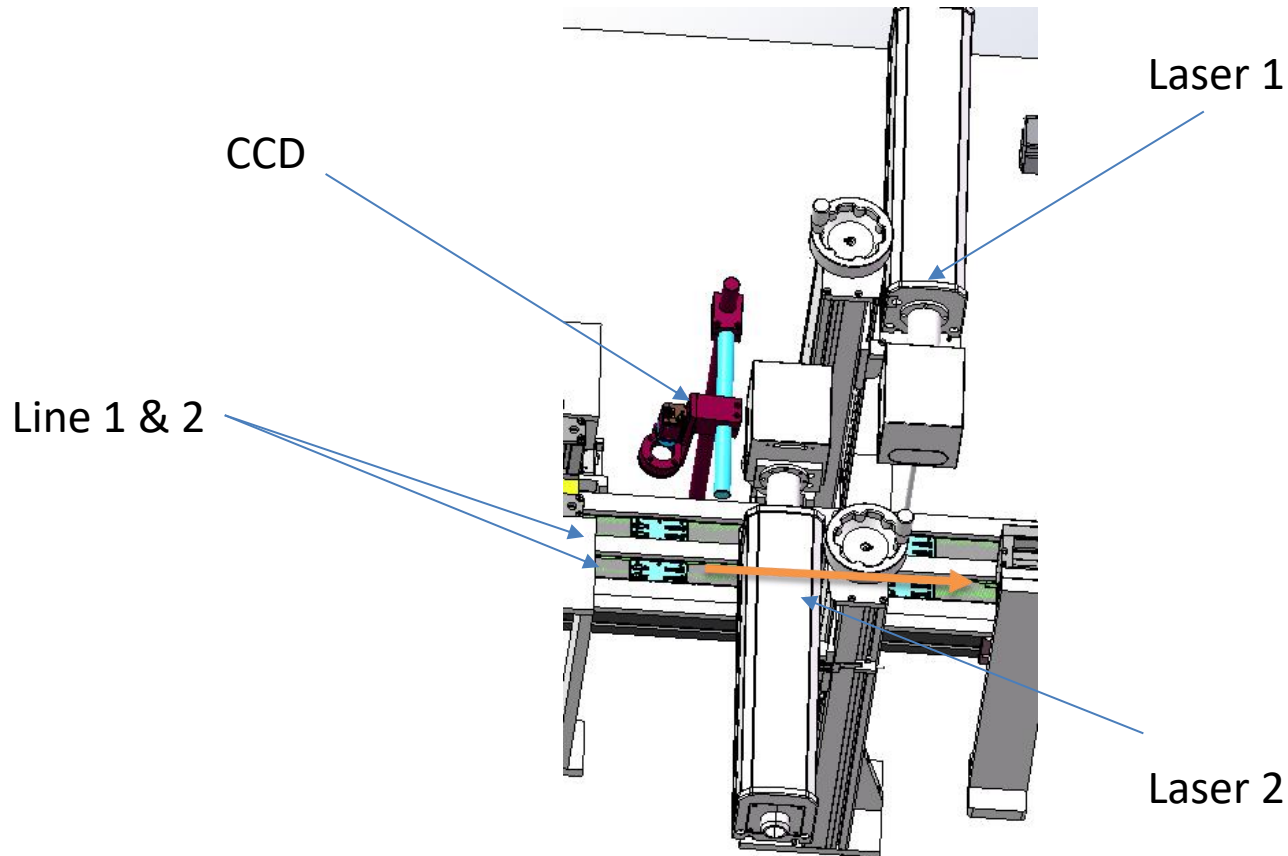

Rapid Test Kit Assembly Machine Multiple Strips In One Cassette

Output

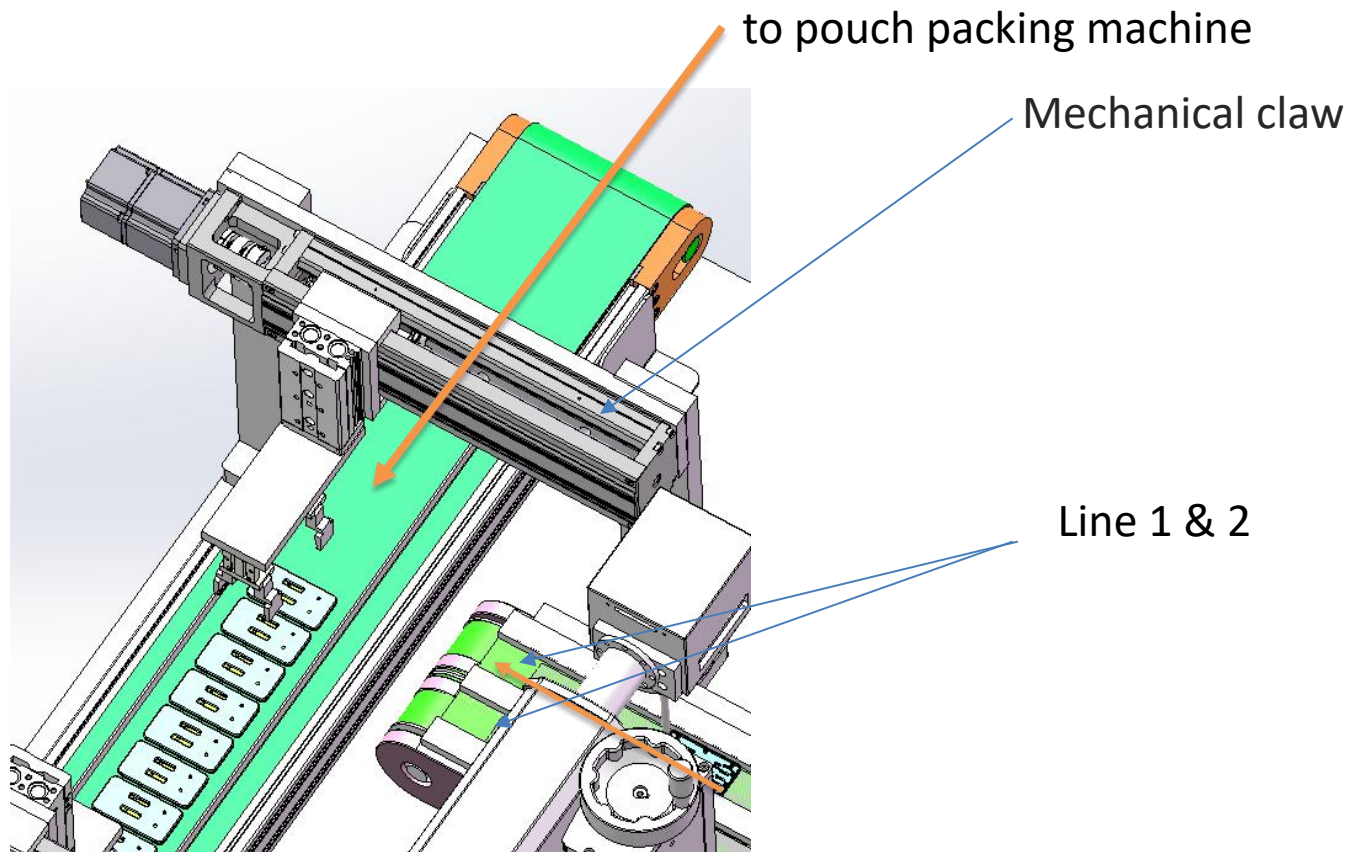

Rapid Test Kit Assembly Machine Multiple Strips In One Cassette

Output

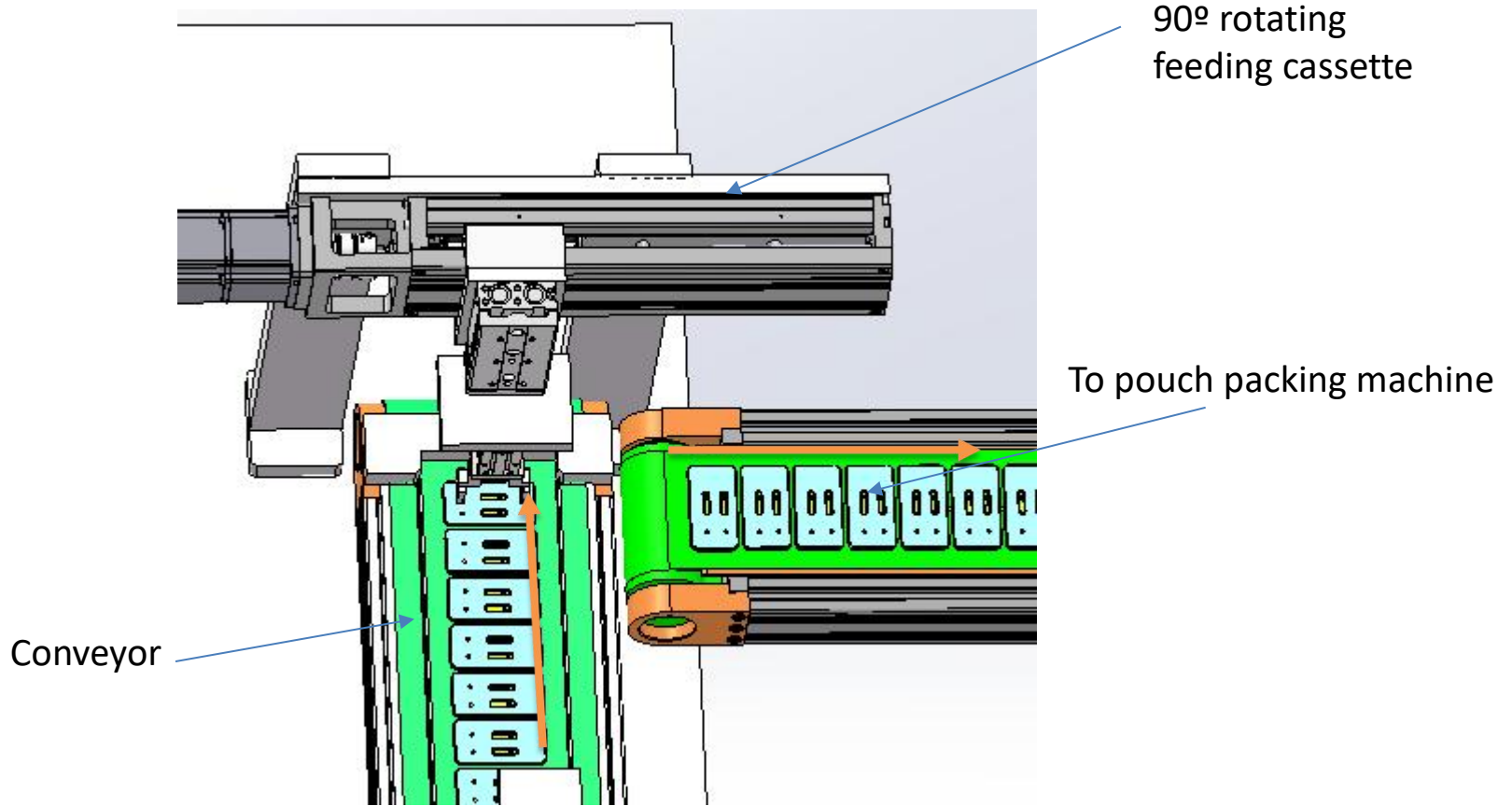

Rapid Test Kit Assembly Machine Multiple Strips In One Cassette

Pouch packing machine

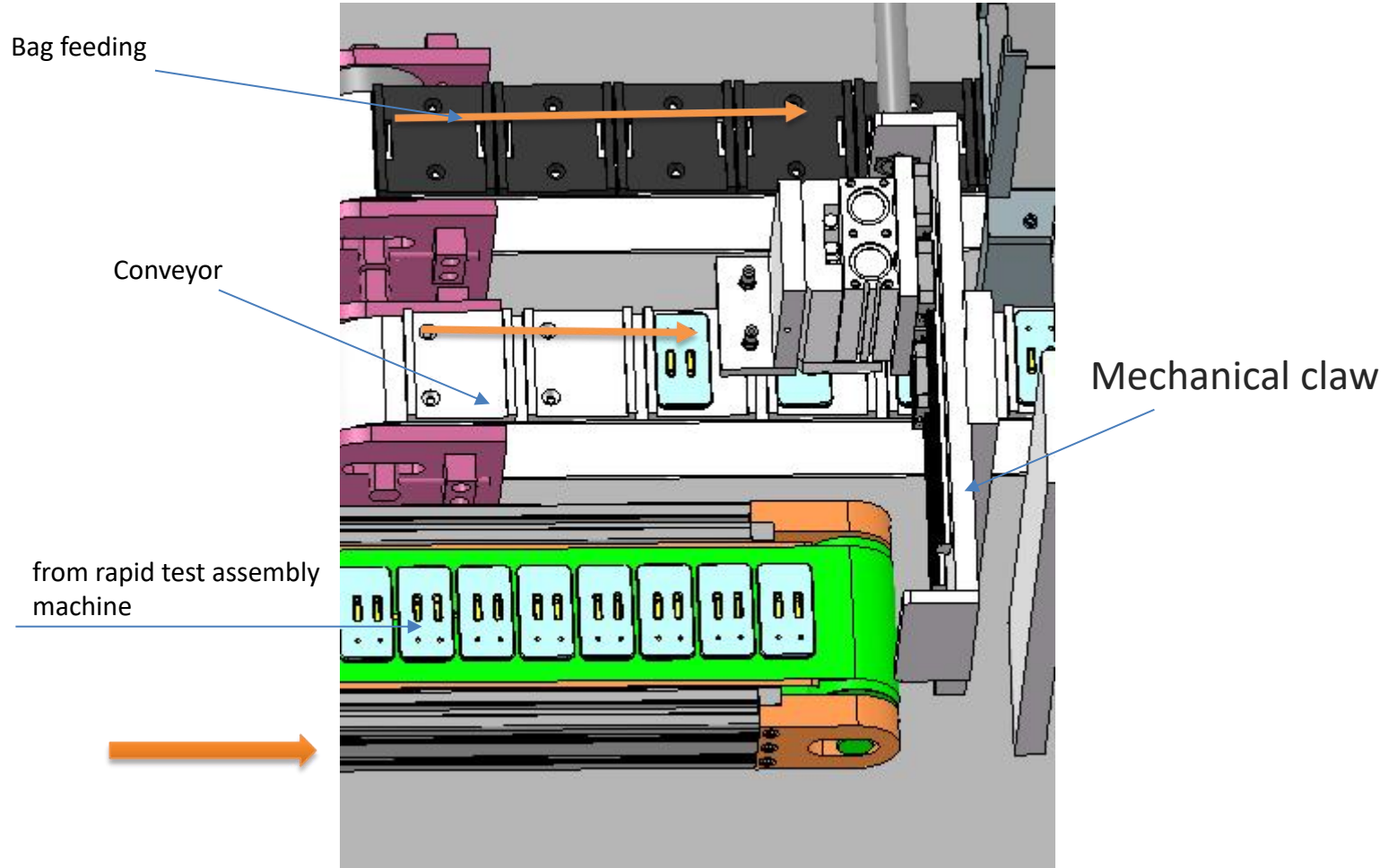

Rapid Test Kit Assembly Machine Multiple Strips In One Cassette

Bag loader

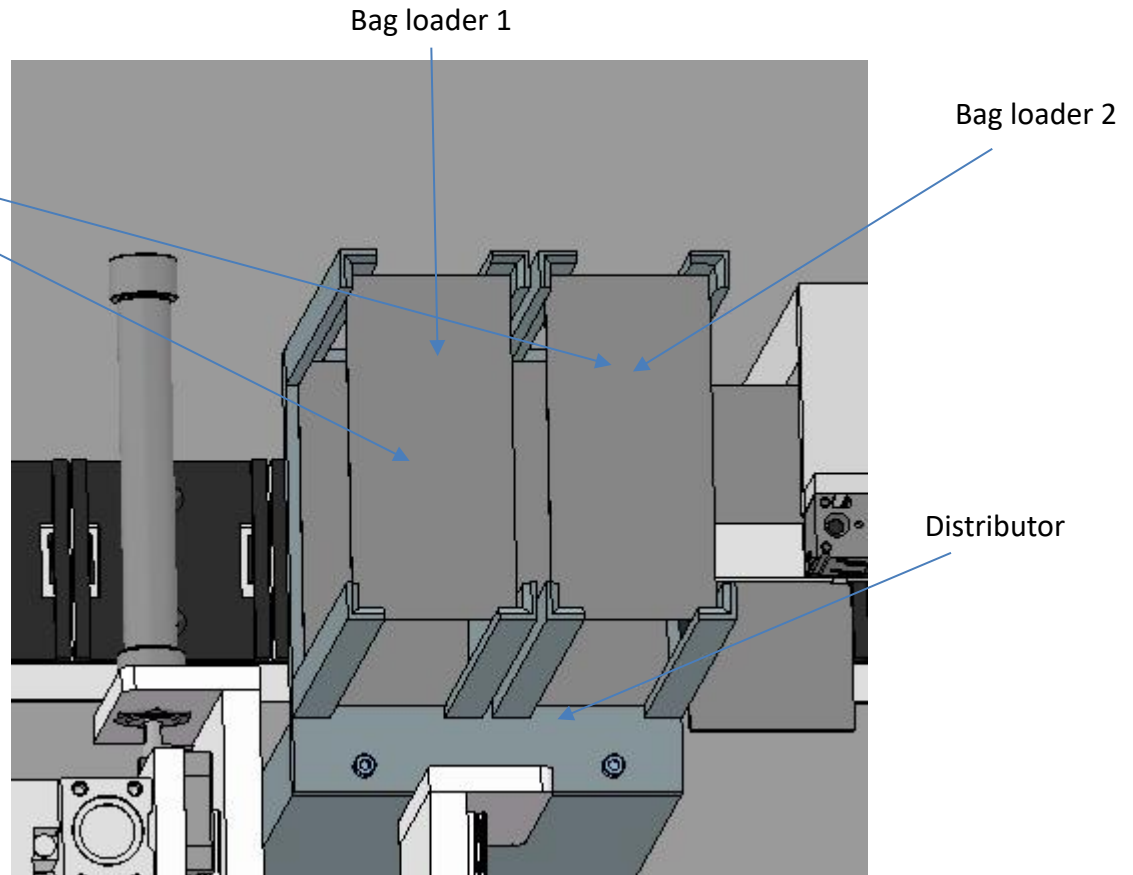

Rapid Test Kit Assembly Machine Multiple Strips In One Cassette

Desiccant roll

Desiccant roll

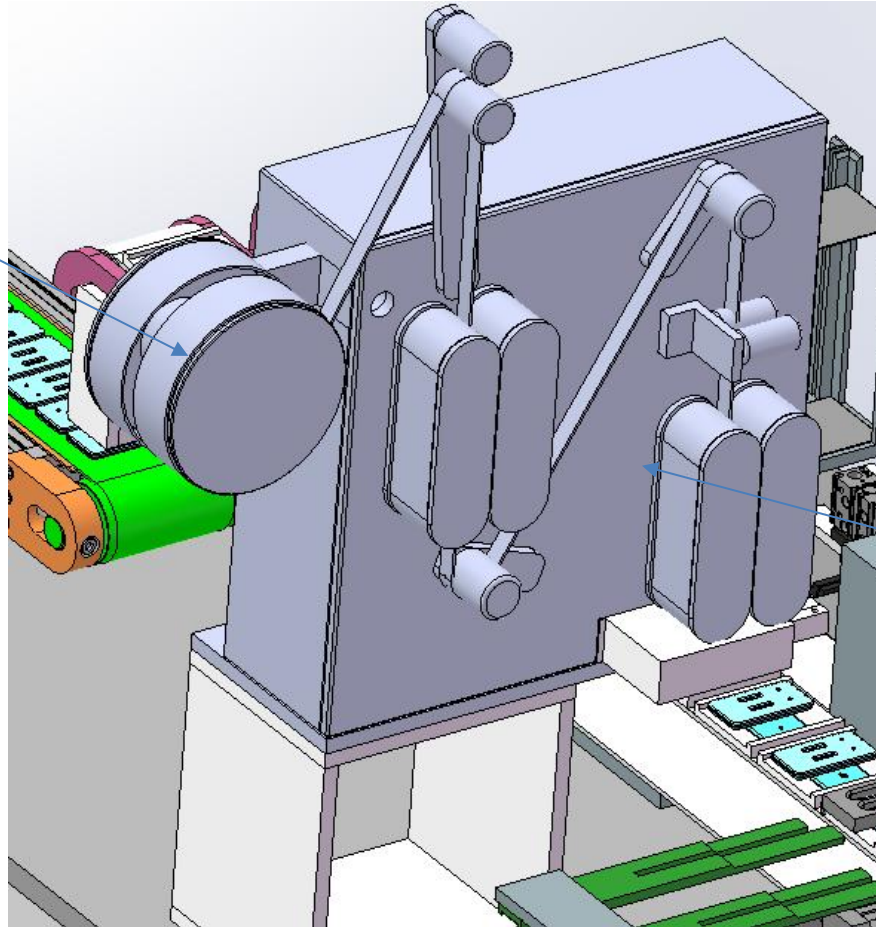

Cutter

Rapid Test Kit Assembly Machine Multiple Strips In One Cassette

Bag press

Bag press

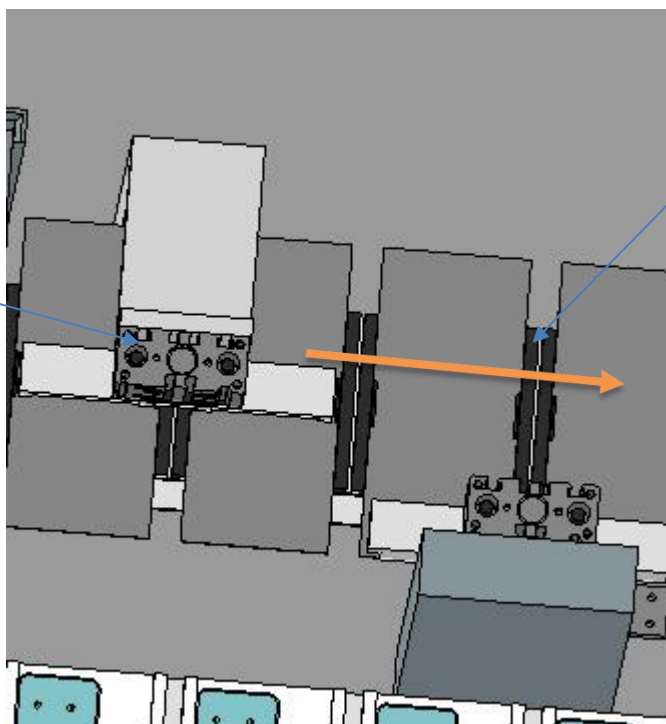

Conveyor

Rapid Test Kit Assembly Machine Multiple Strips In One Cassette

Bag open

Bag open 1

Bag open 2

Pusher



Rapid Test Kit Assembly Machine Multiple Strips In One Cassette

Bag press

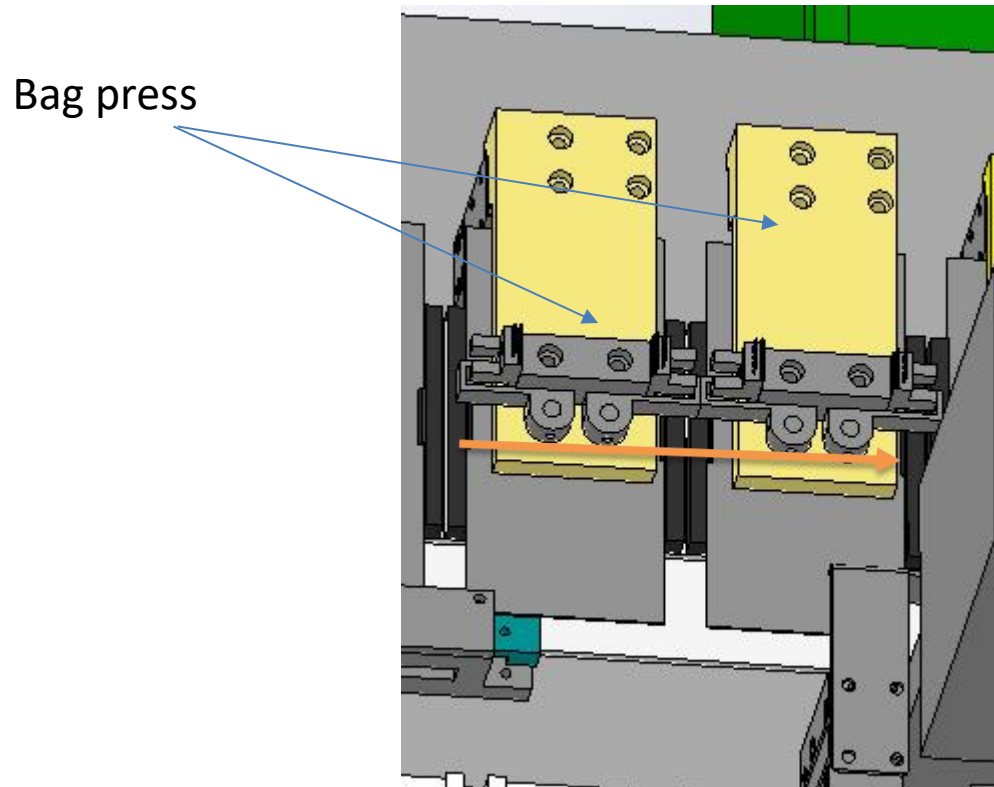

Rapid Test Kit Assembly Machine Multiple Strips In One Cassette

Bag seal

Heat & seal

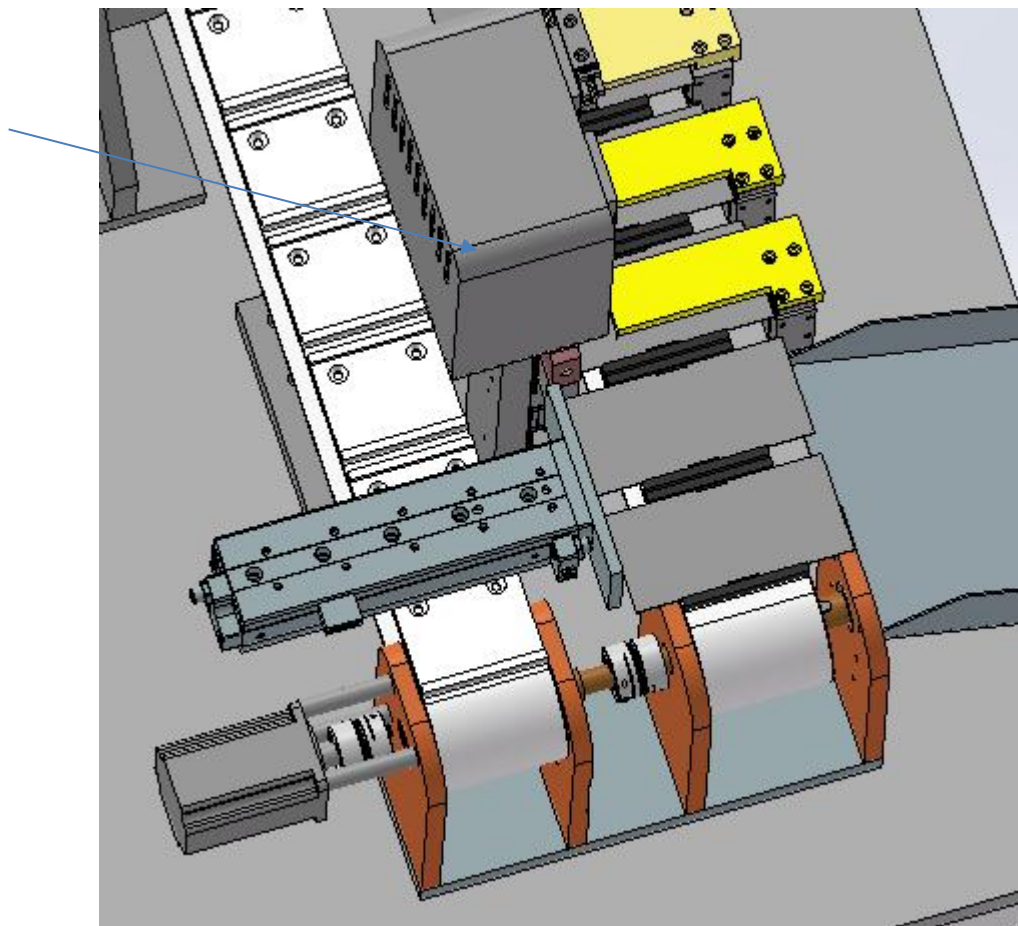

Rapid Test Kit Assembly Machine Multiple Strips In One Cassette

Output

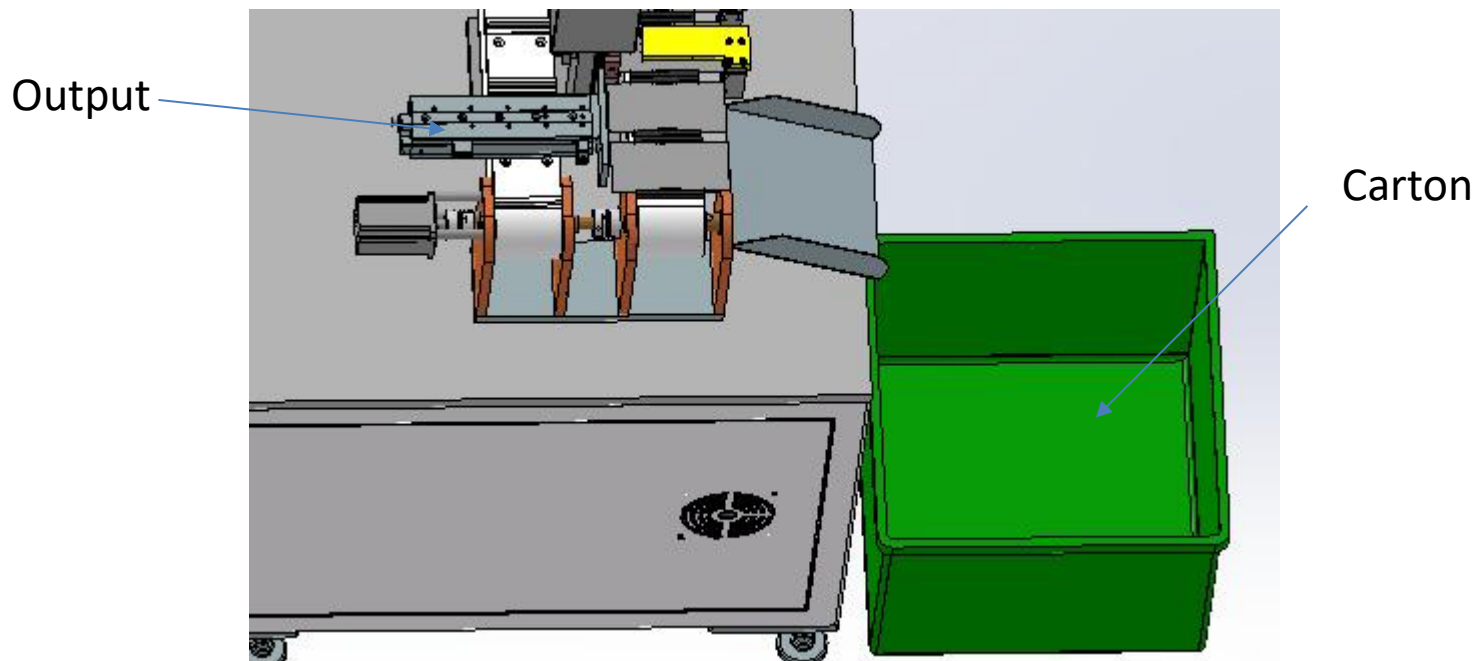

Rapid Test Kit Assembly Machine

Multiple Strips In One Cassette

Features:

1. Touch screen
2. Capacity: 2,000 bottles/hour
3. Fully automated assembly
4. Easy to use

Operation:

1. Connect power supply and air supply
2. Place cassette bottom into lift
3. Place cassette cover into lift
4. Place uncut sheets to loader
5. Install desiccant roll
6. Place foil bag into loader
7. Start running

Rapid Test Kit Assembly Machine

Multiple Strips In One Cassette

Parameters	
Capacity	2,000 bottles/H
Activation	90%
Air supply	0.5~0.8MPa
Power supply	AC220V/50Hz
Internal power	DC/24V
Power	23.0 KW
Weight	1500kg
Dimension	L6.24 * W2.4 * H1.8m
Wooden packing	---

Rapid Test Kit Assembly Machine

Multiple Strips In One Cassette

Key components	
PLC	Mitsubishi/Panasonic/other
Operation system	ANTITECK
Servo	Inovance/KNK
Relay	Schneider/CHNT
Sensor	OMRON/Panasonic
Cylinder	SMC/AIRTAC
Solenoid valve	SMC/AIRTAC
Connector	SMC/AIRTAC