

## Rapid Test Kit Packing Machine + Automated Boxing Machine

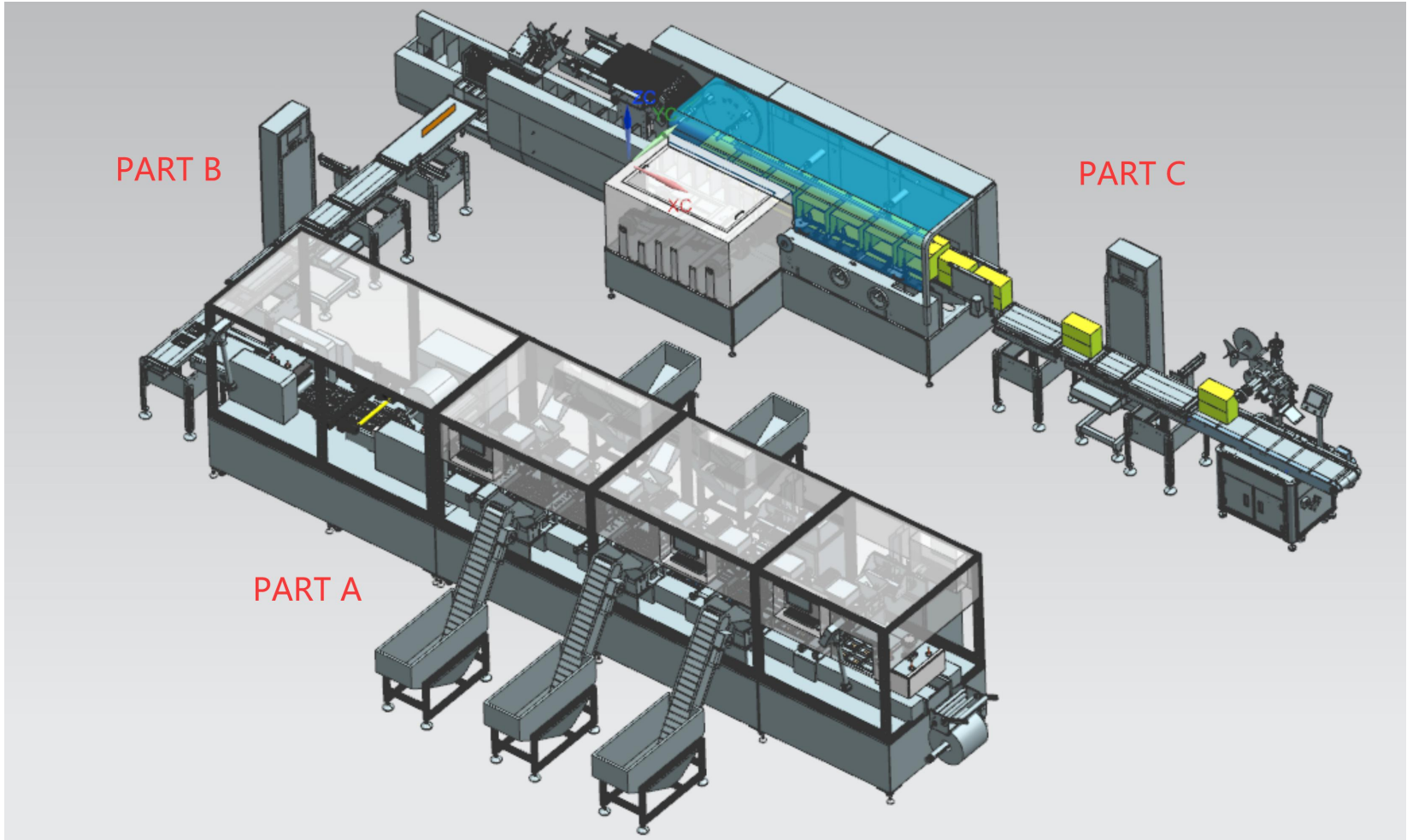

## Rapid Test Kit Packing Machine + Automated Boxing Machine

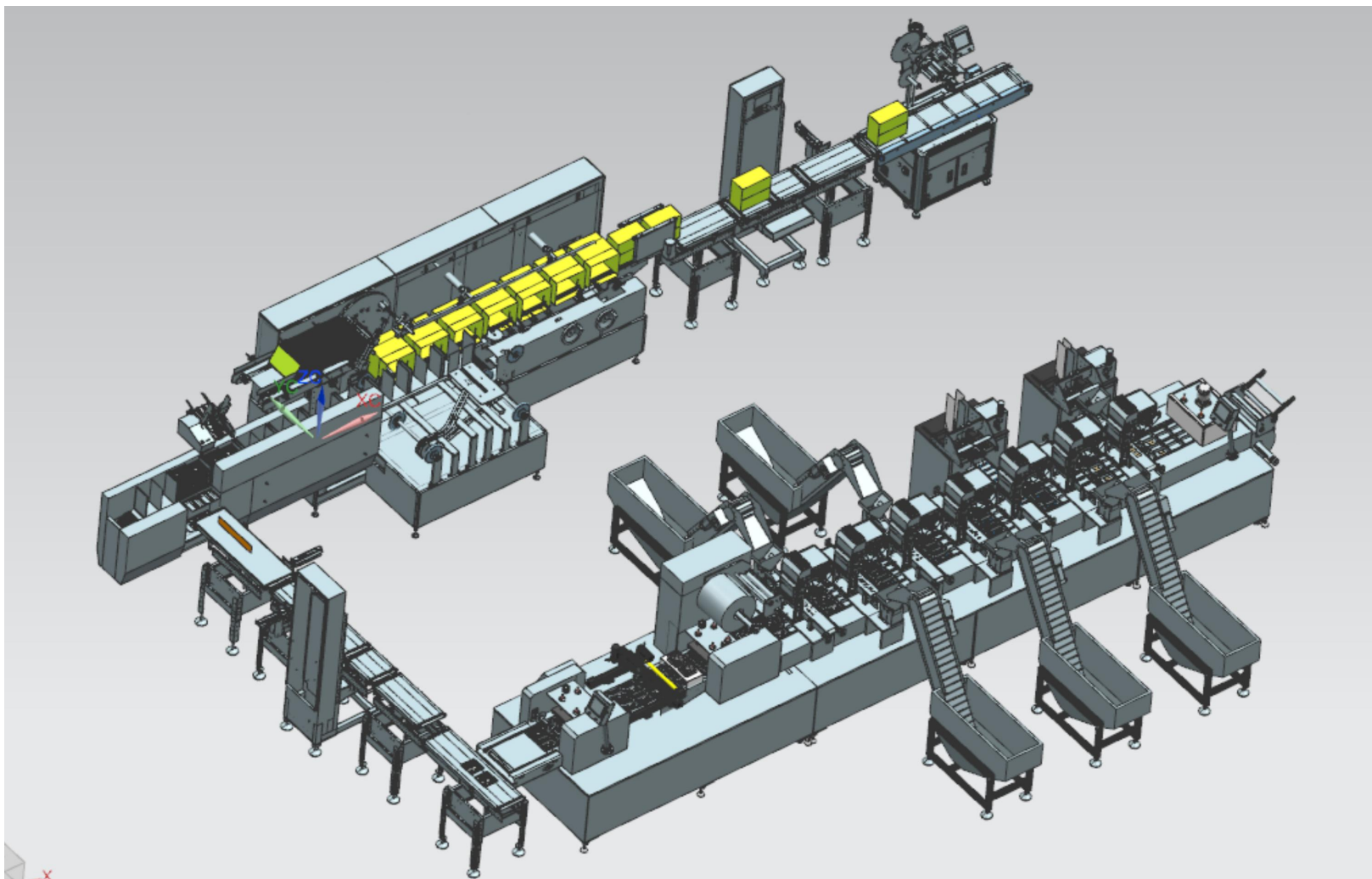

# Rapid Test Kit Packing Machine + Automated Boxing Machine

## Overview

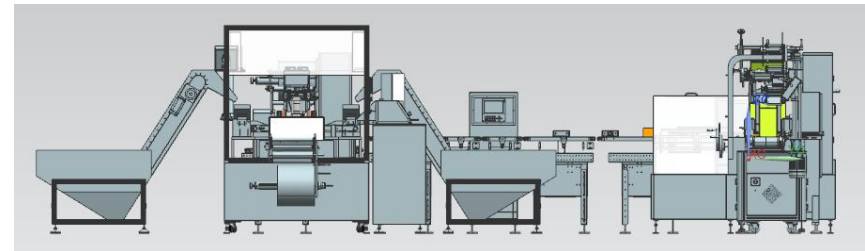
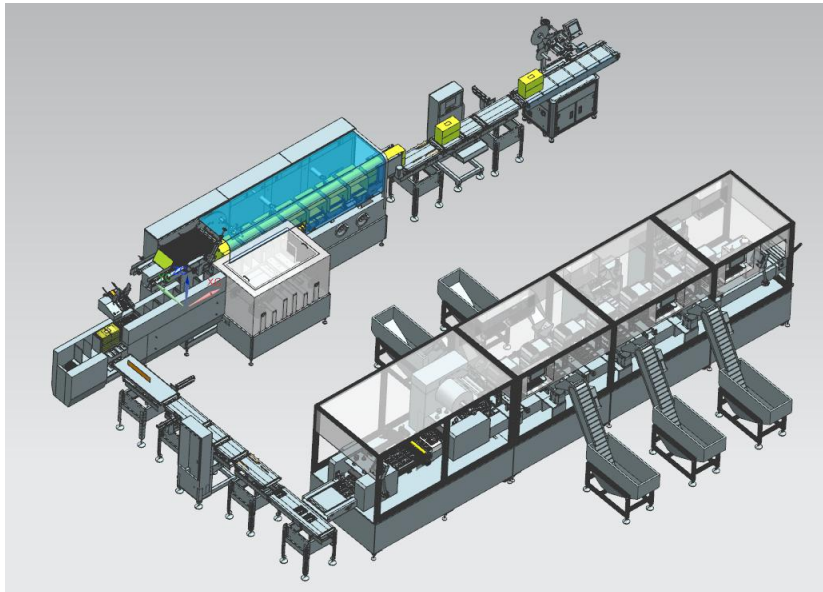
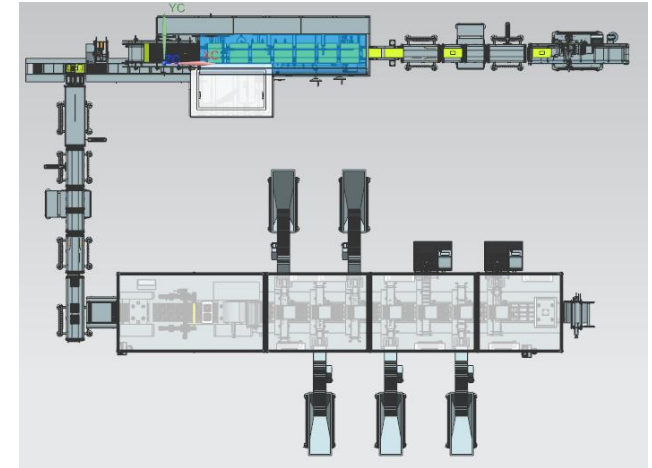
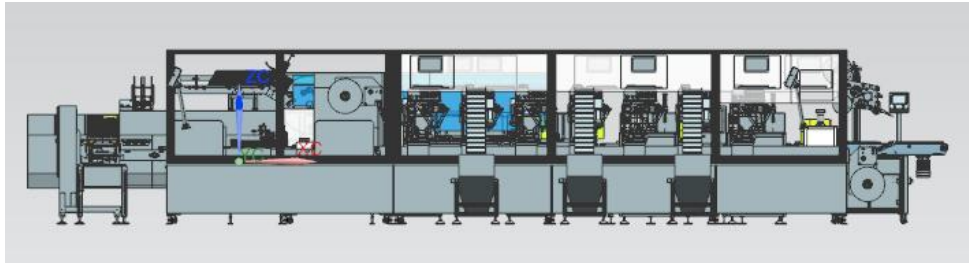

## Rapid Test Kit Packing Machine + Automated Boxing Machine

### Layout

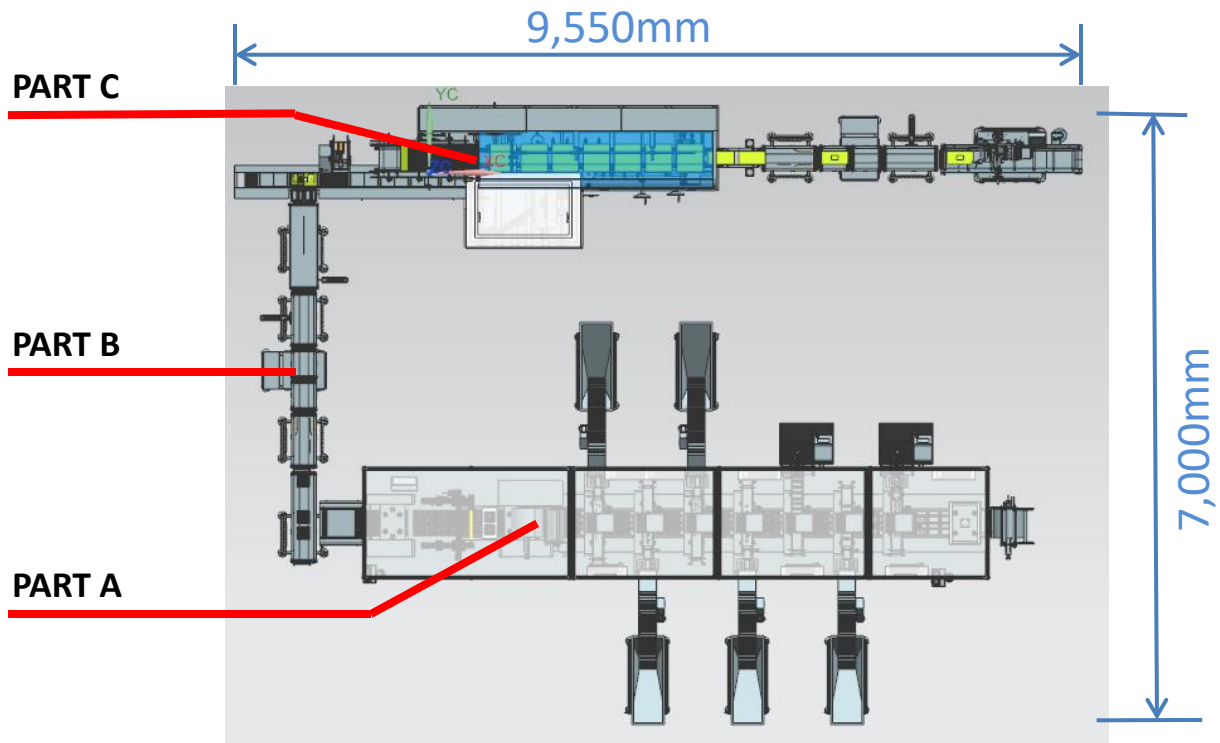

**L9,550\*W7,000\*H1,800mm**

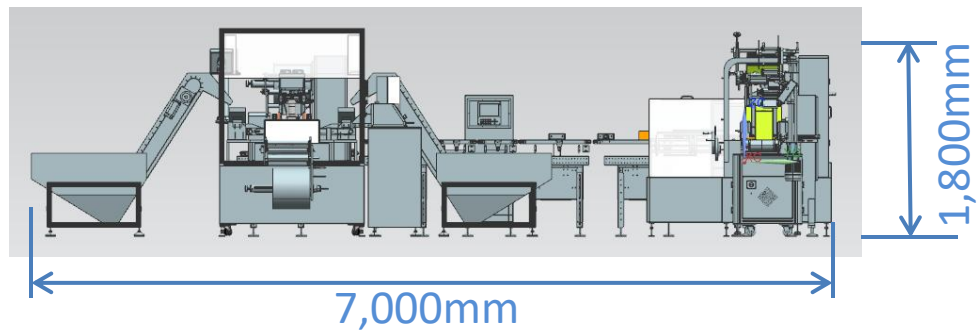

## PART A Rapid Test Kit Packing Machine

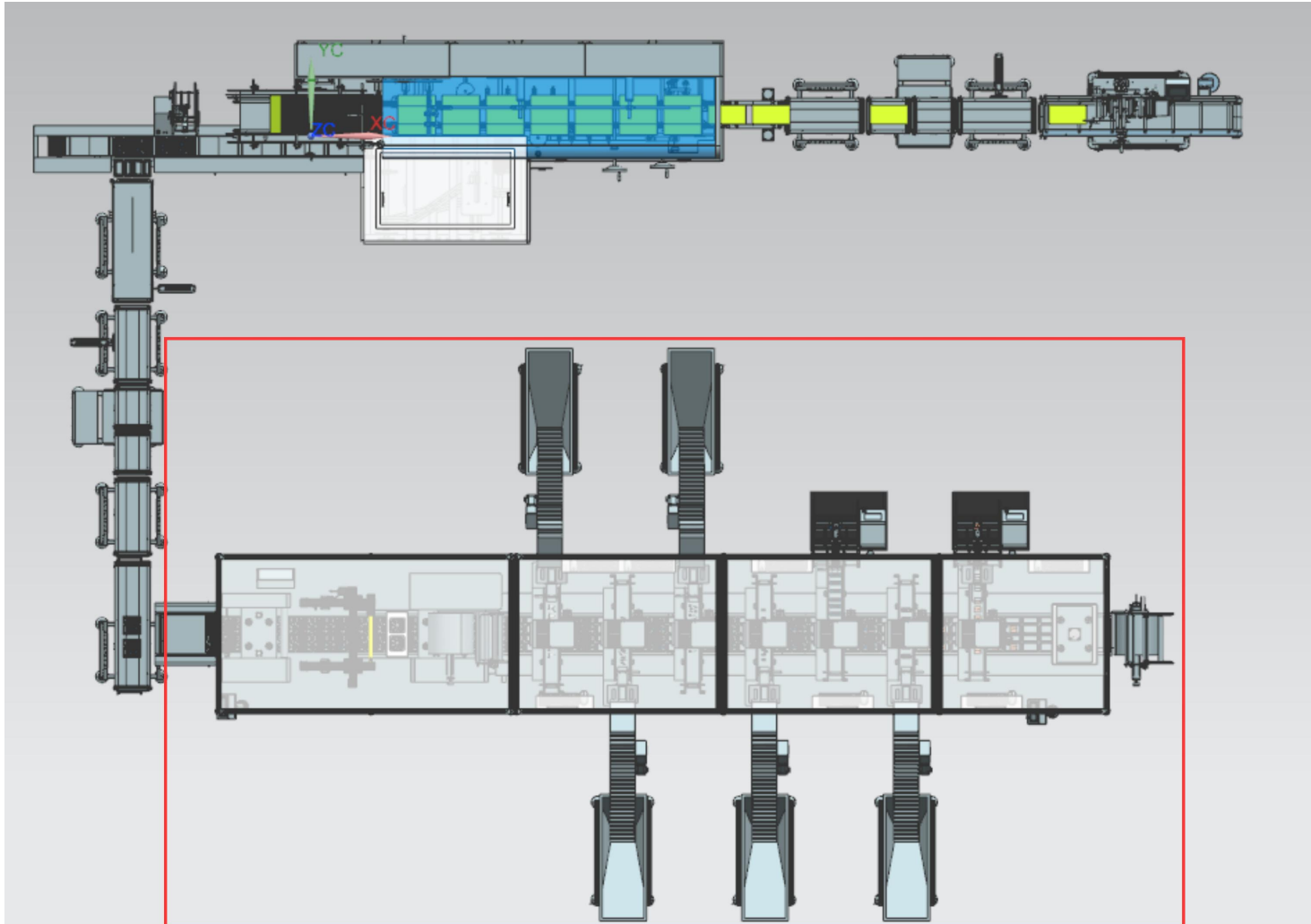



## PART A

### Rapid Test Kit Packing Machine

#### Packing Requirement



## PART A

### Rapid Test Kit Packing Machine

#### Packing Requirement



# PART A

## Rapid Test Kit Packing Machine

### Pouch Size

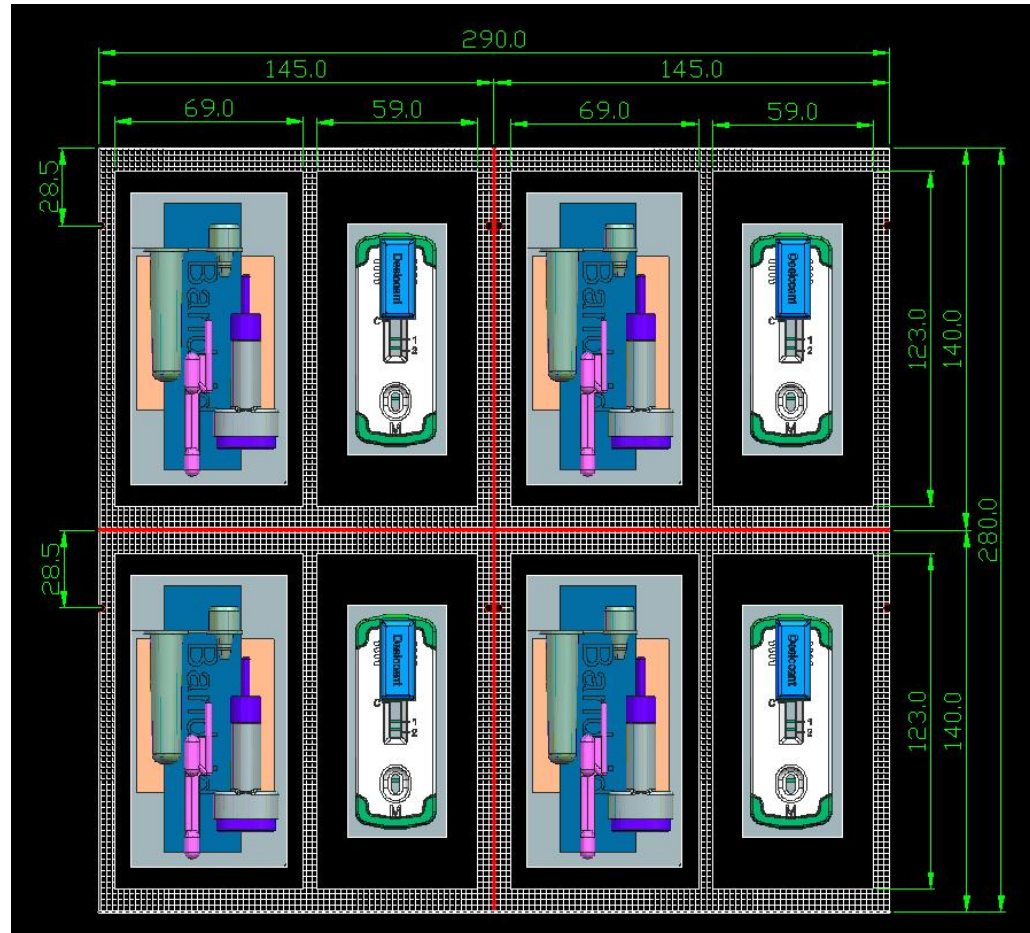



## PART A Rapid Test Kit Packing Machine

### Foil Film

Cover film, 0.08mm thickness, 305.0mm width, 300m length



Film waste recycle  
8.0mm each side

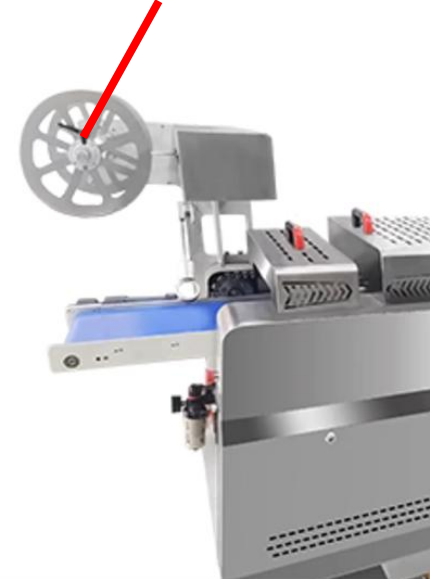

Back film, 0.10mm thickness,  
320.0mm width, 300m length

## PART A Rapid Test Kit Packing Machine

### Overview

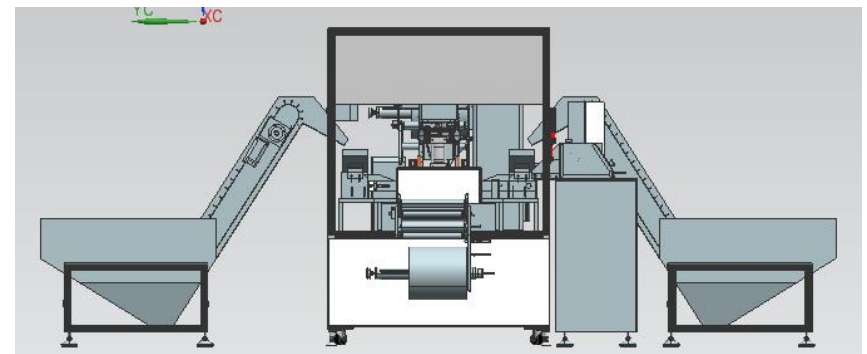
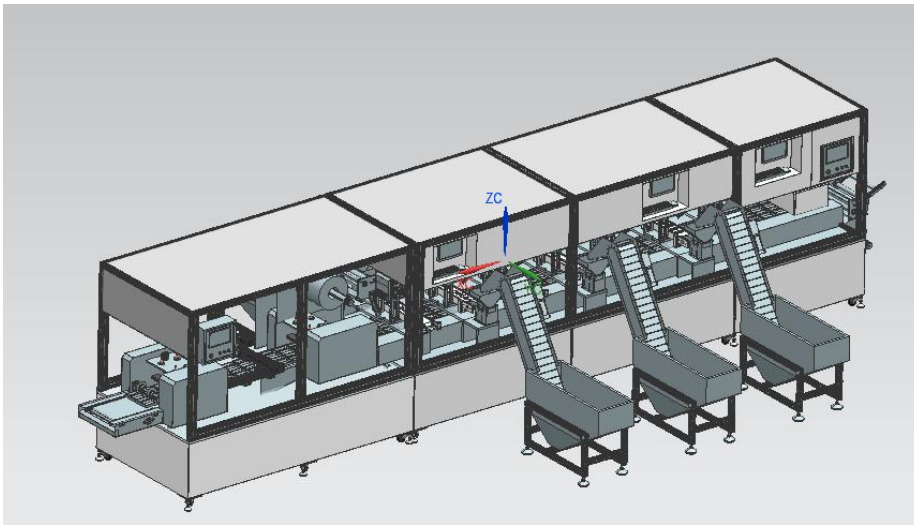
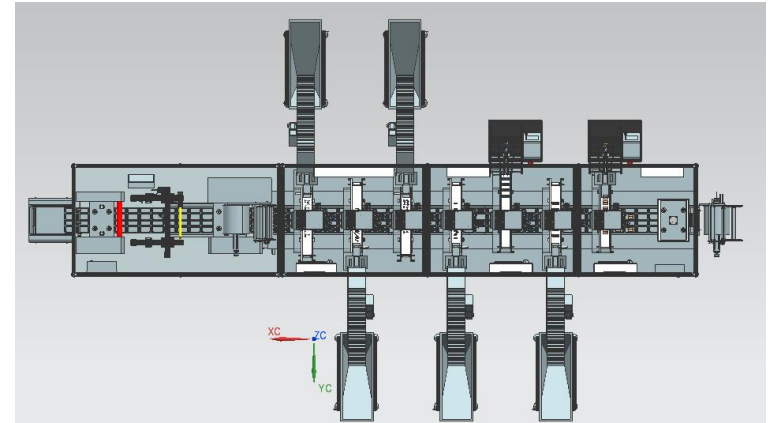
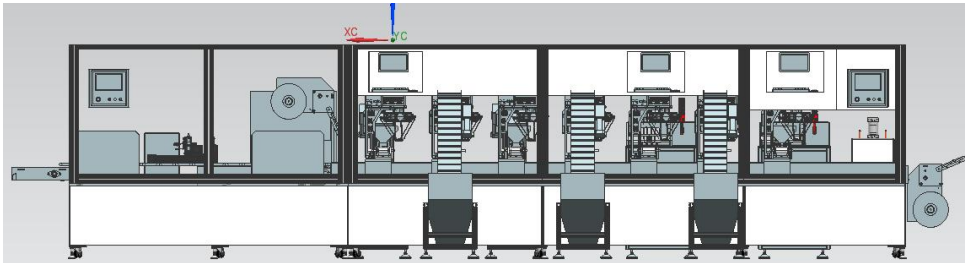

## PART A Rapid Test Kit Packing Machine

Dimension

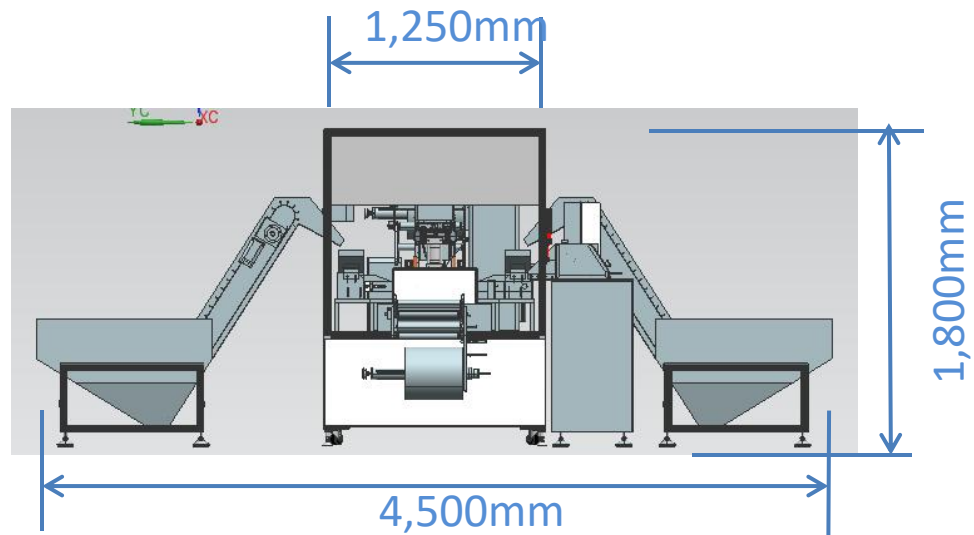
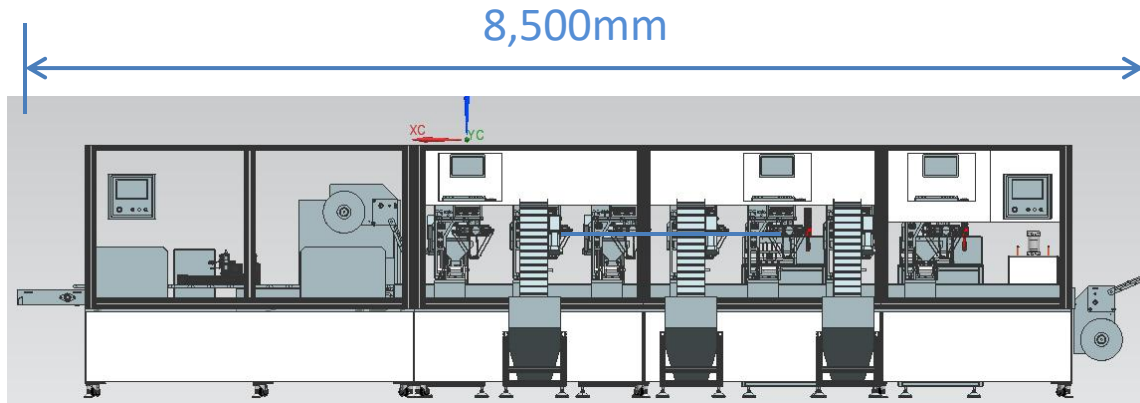

**8,500\*4,500\*1,800mm**  
L \* W \* H

## PART A Rapid Test Kit Packing Machine

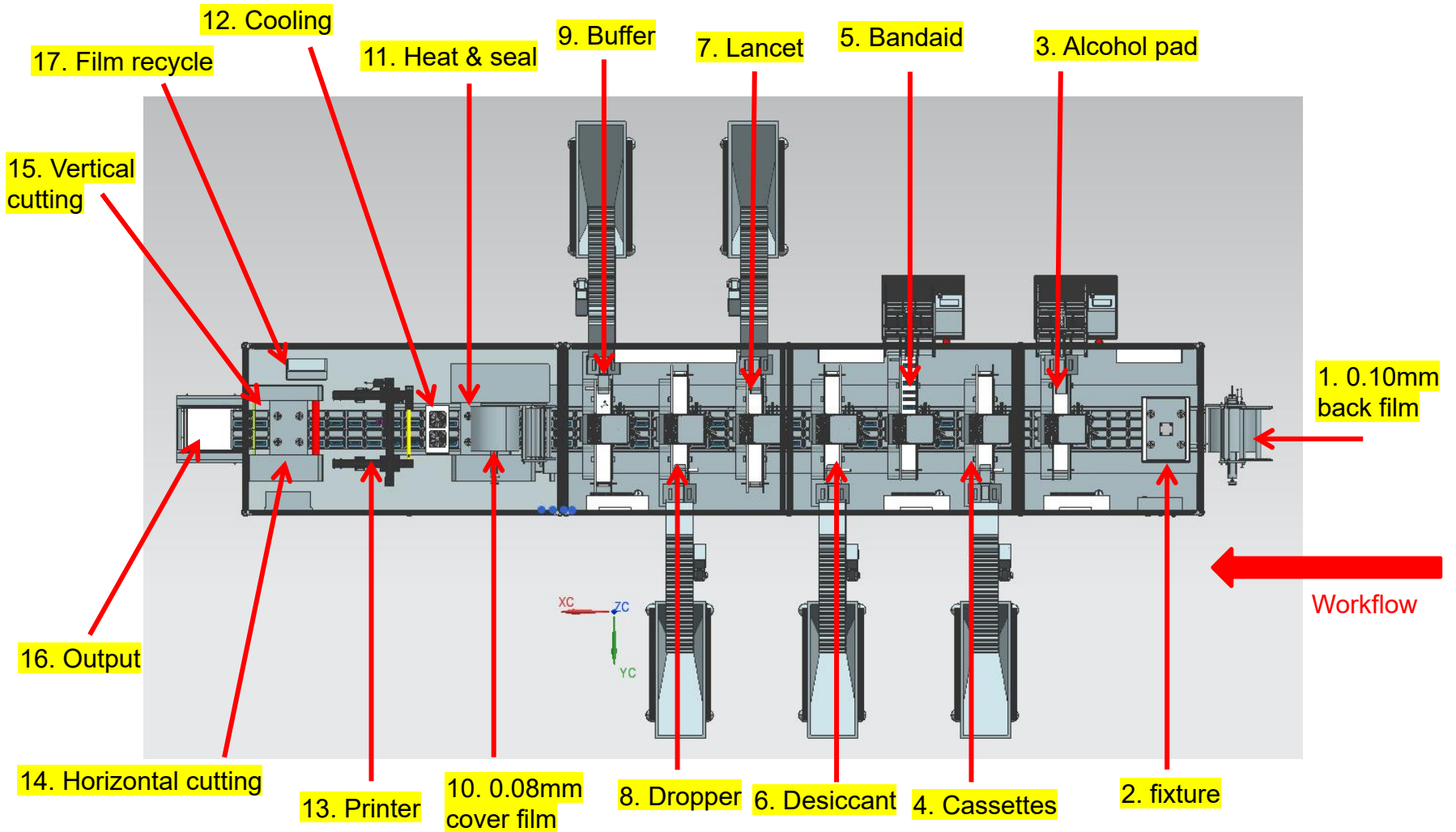

## PART A Rapid Test Kit Packing Machine

### Fixture

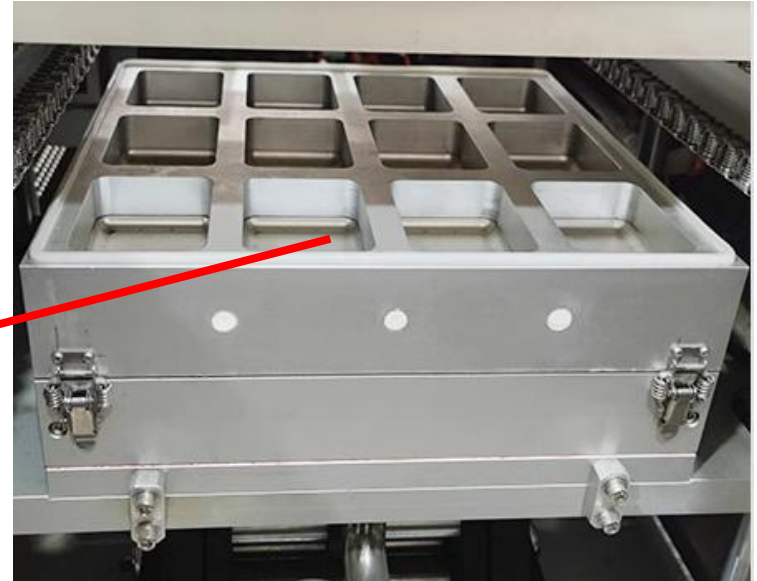
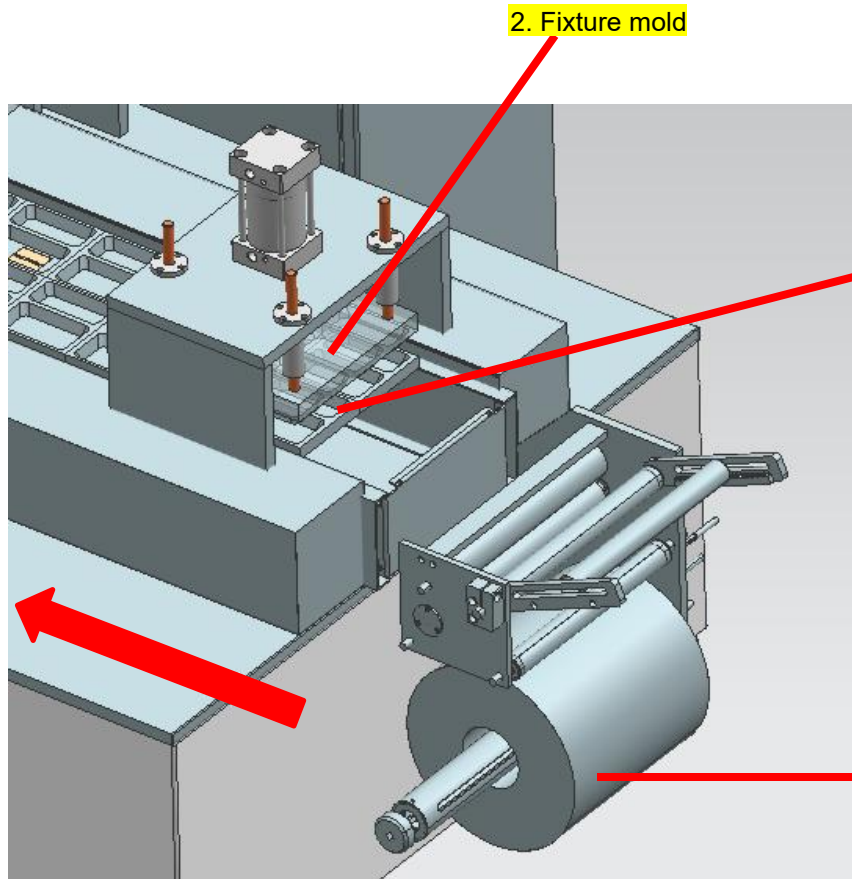

*Similar one, maybe will change according to design*

**1. 0.10mm thickness, 322mm width, 300 meter per roll**



## PART A Rapid Test Kit Packing Machine

### Alcohol Pad Feeding

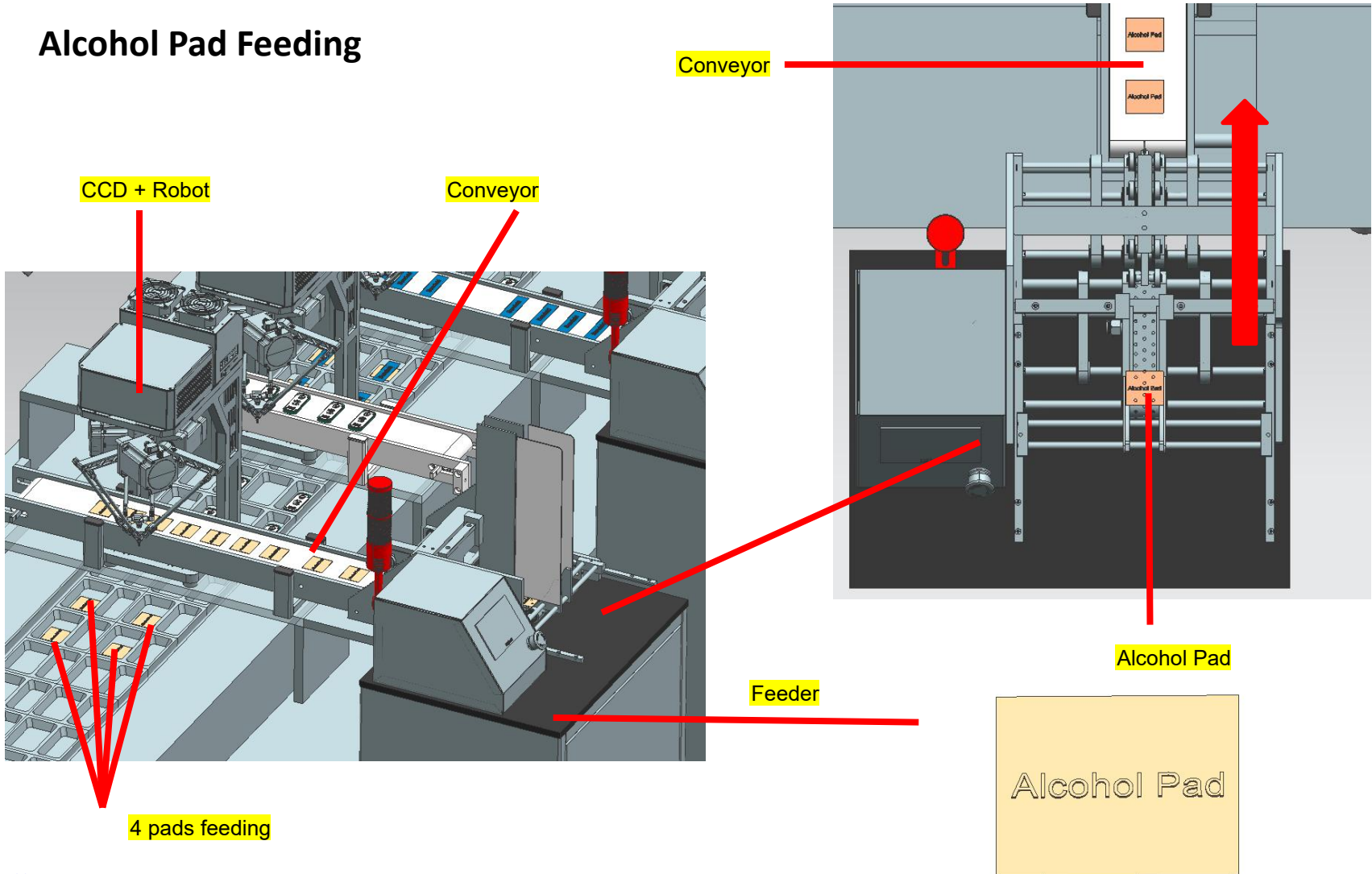

## PART A Rapid Test Kit Packing Machine

### Cassettes Feeding

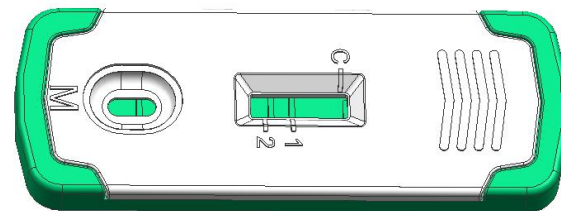
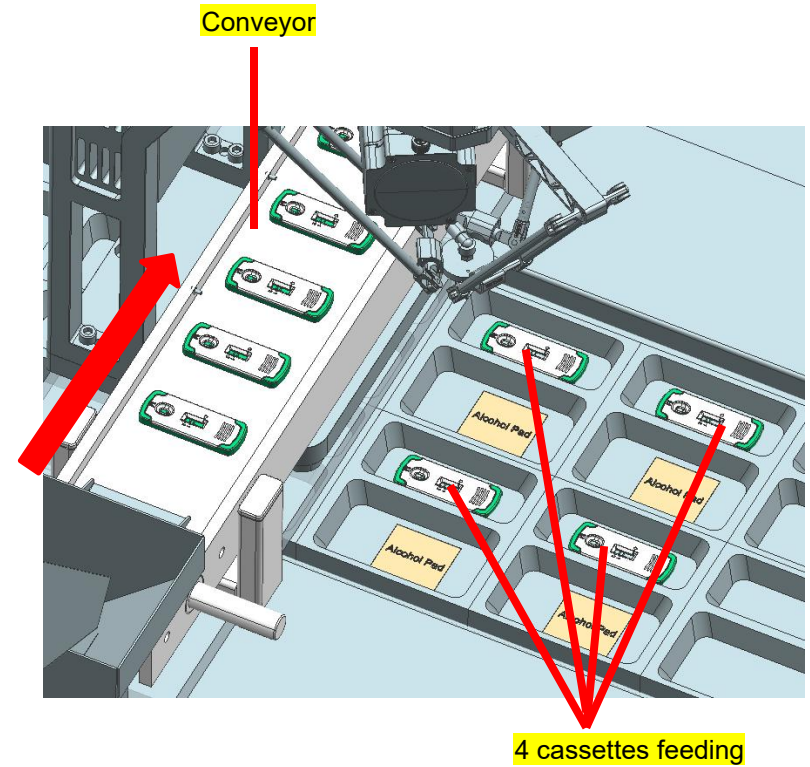
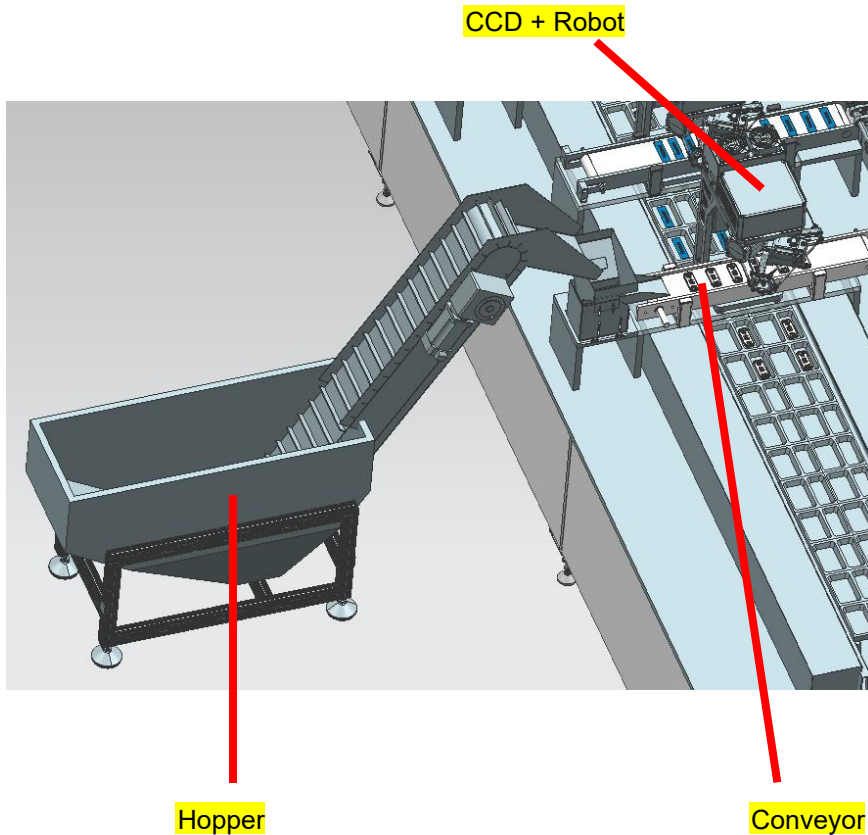

## PART A Rapid Test Kit Packing Machine

### Bandaïd Feeding

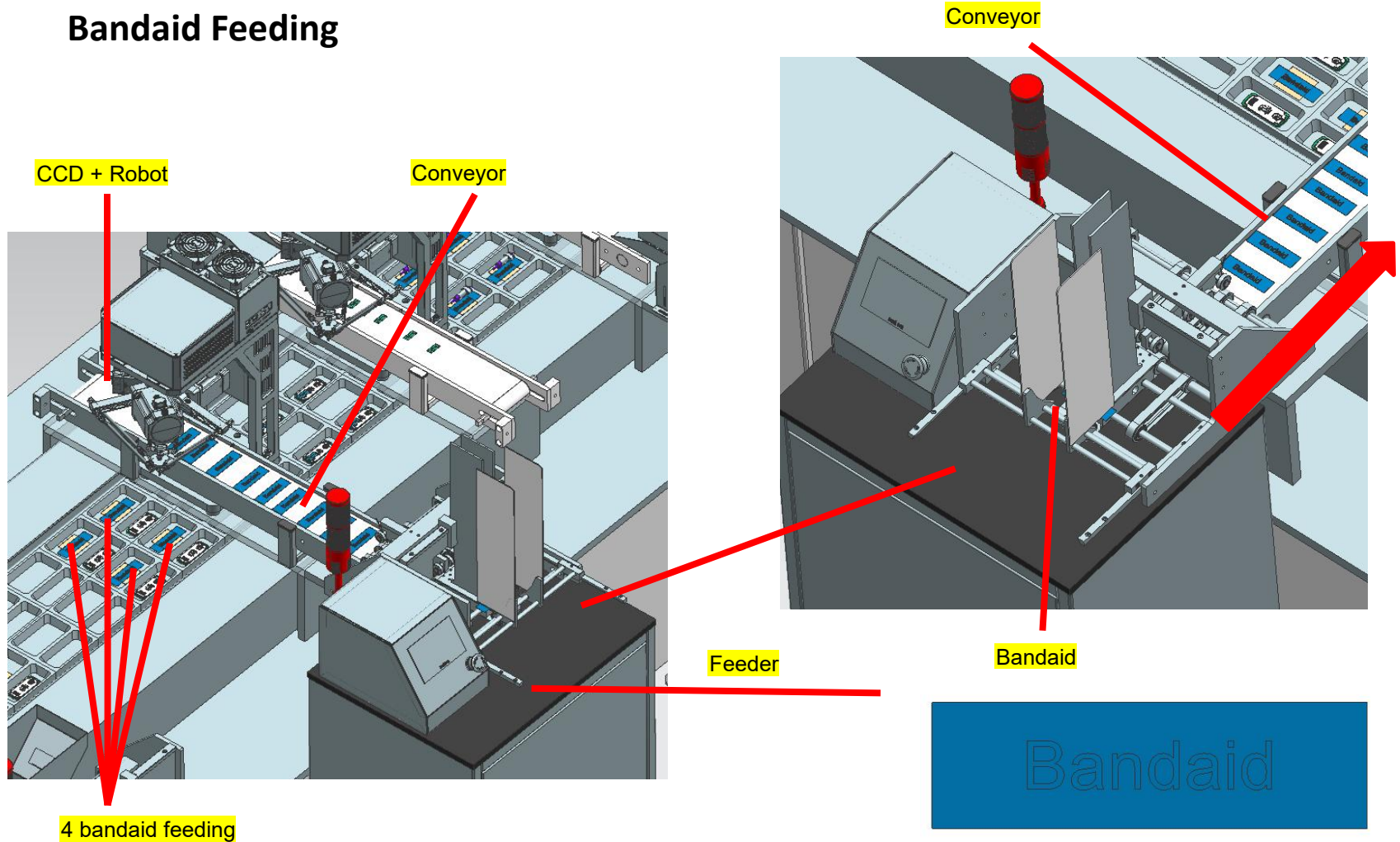



## PART A Rapid Test Kit Packing Machine

### Desiccant Feeding

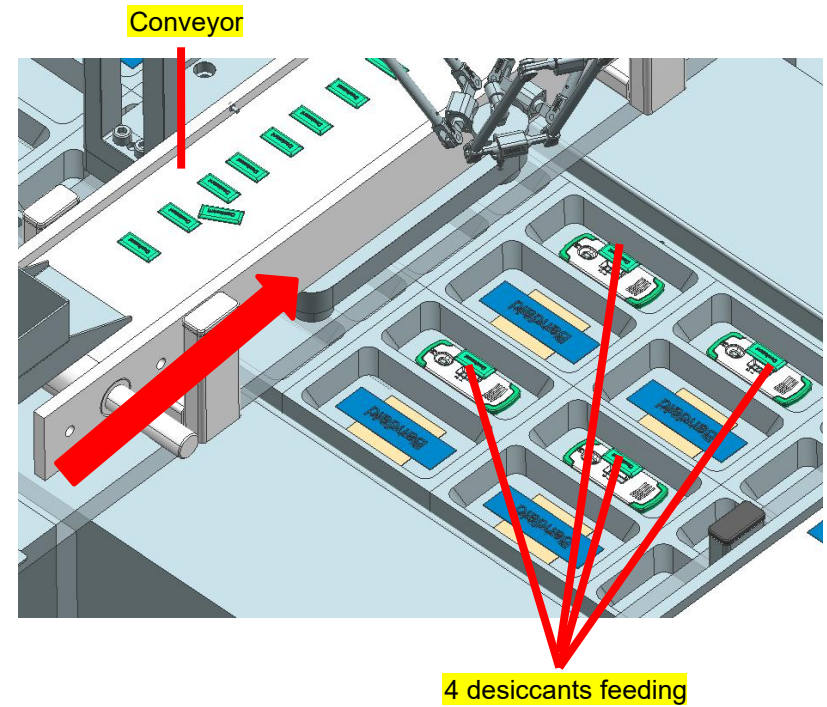
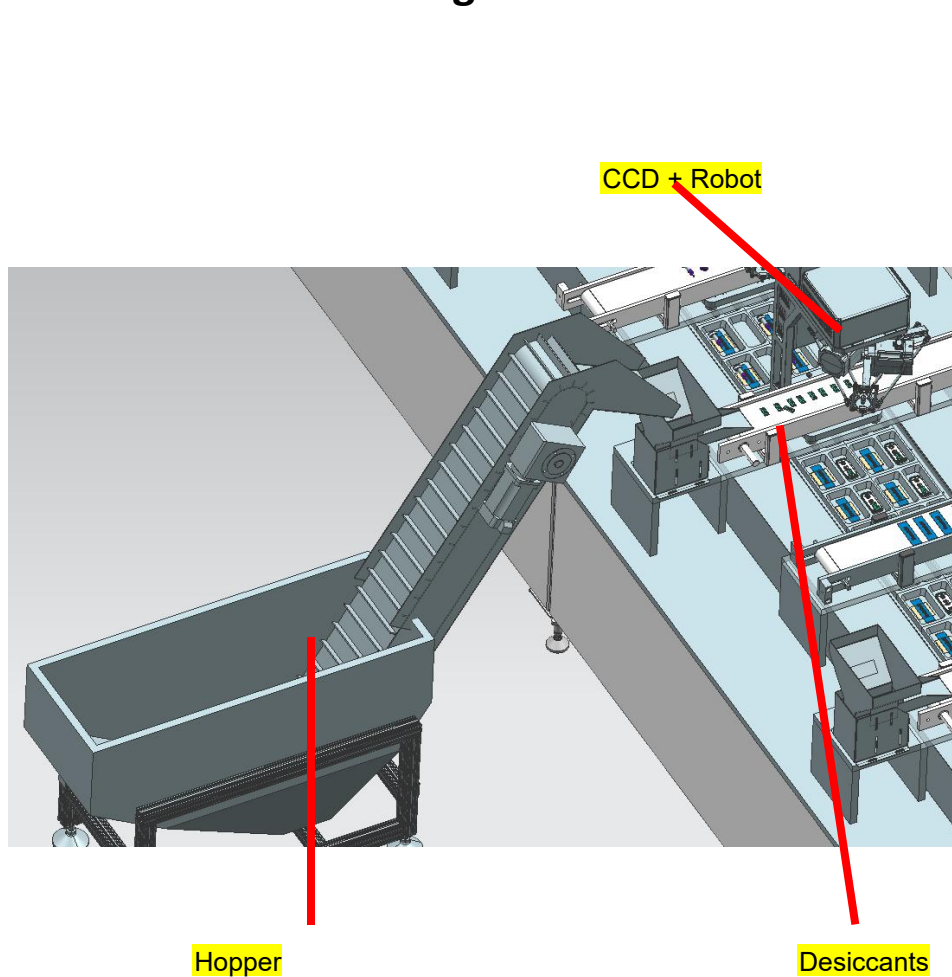

## PART A Rapid Test Kit Packing Machine

### Lancet Feeding

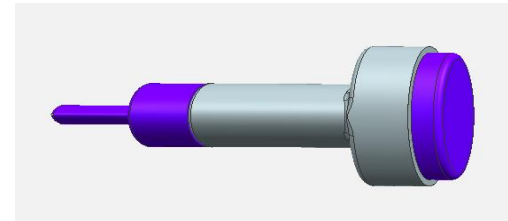
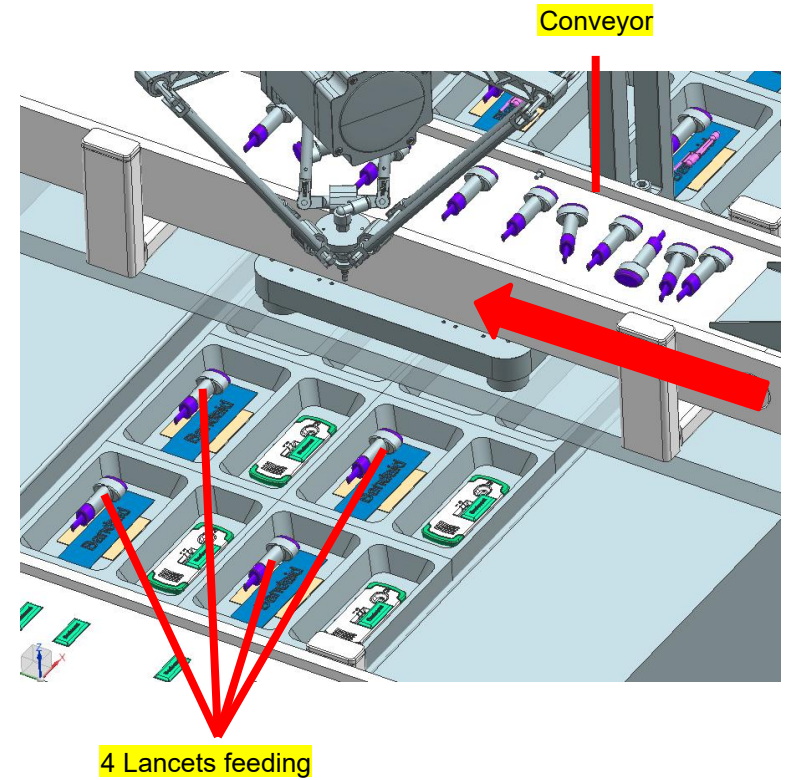
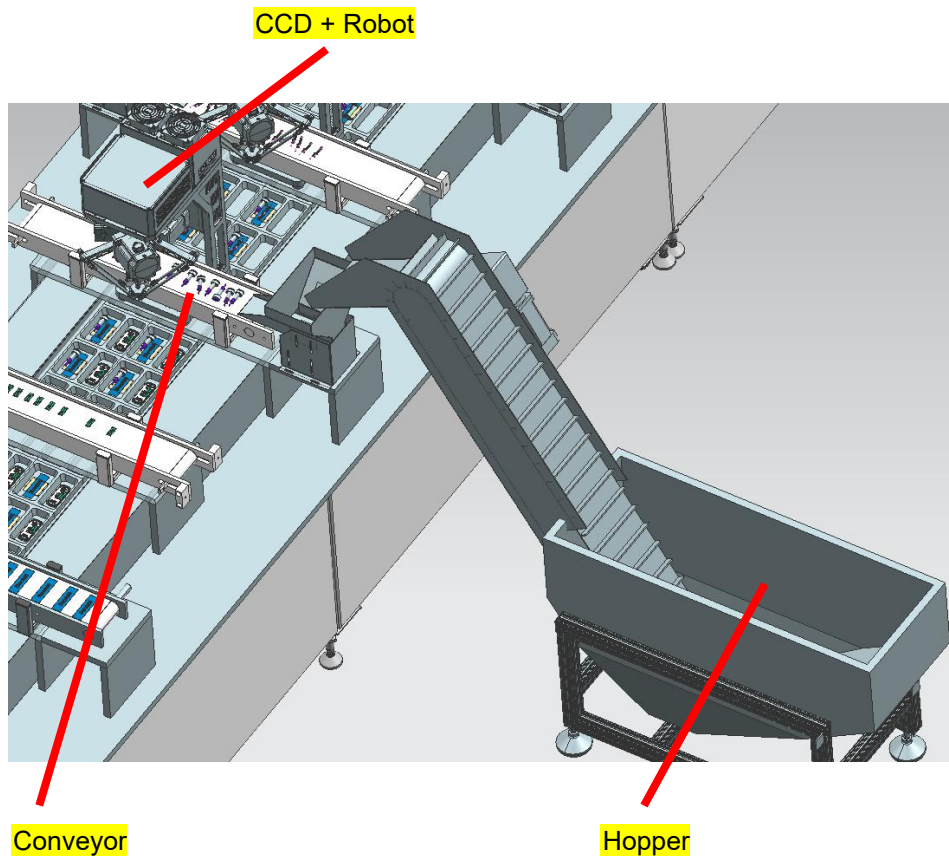



## PART A Rapid Test Kit Packing Machine

### Dropper Feeding

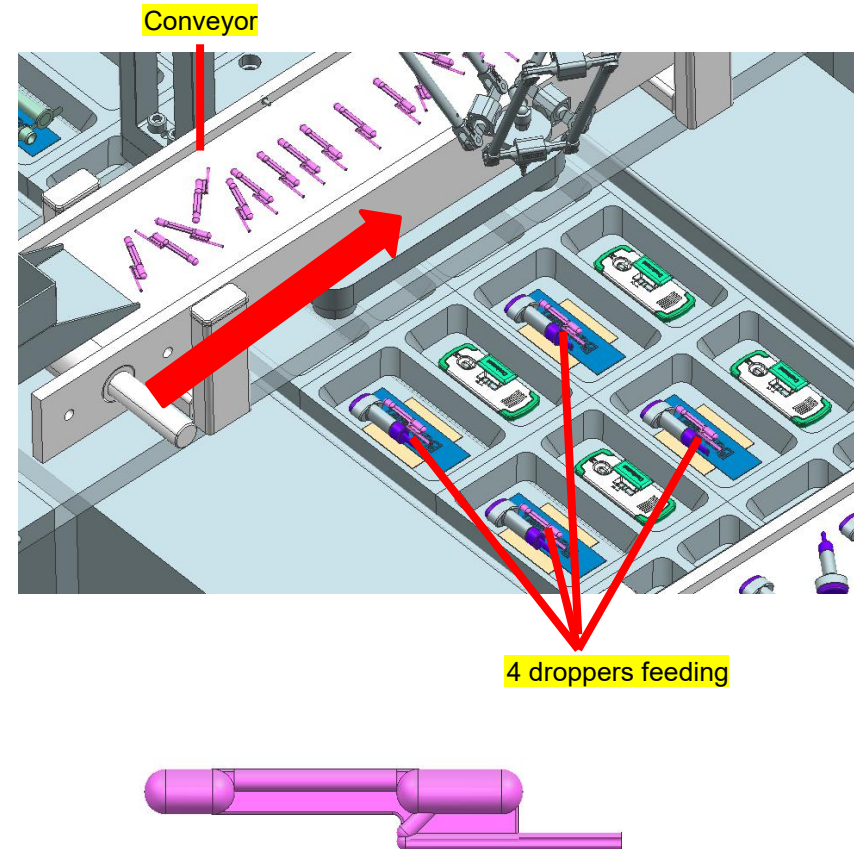
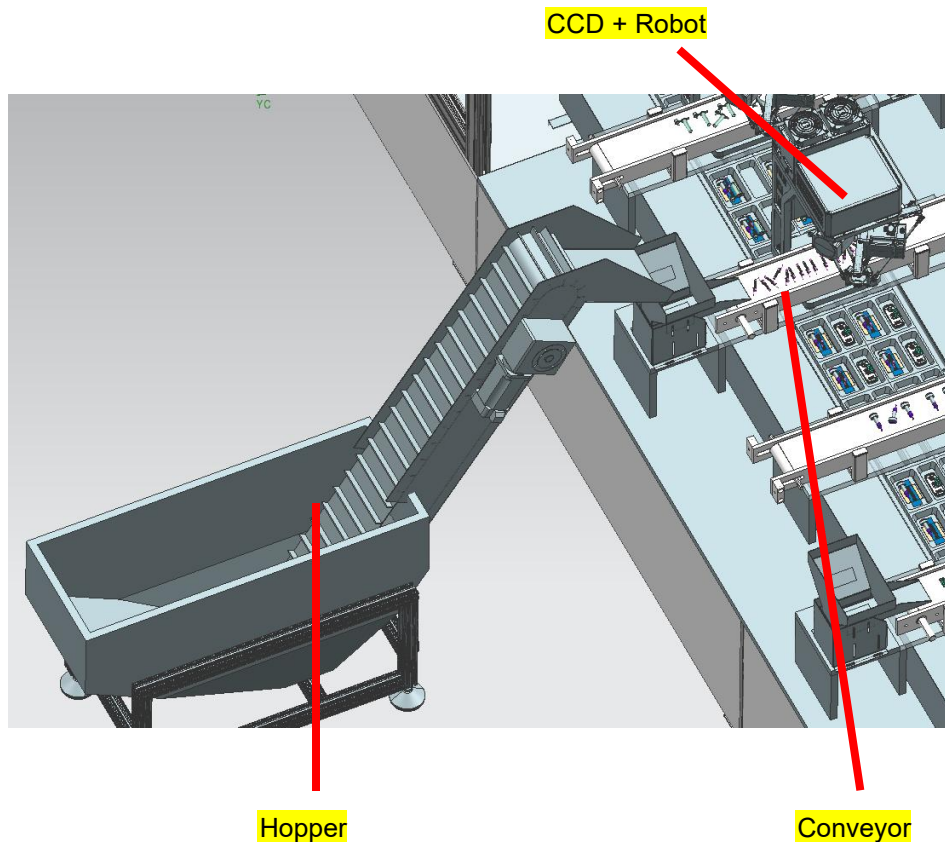

## PART A Rapid Test Kit Packing Machine

### Buffer Feeding

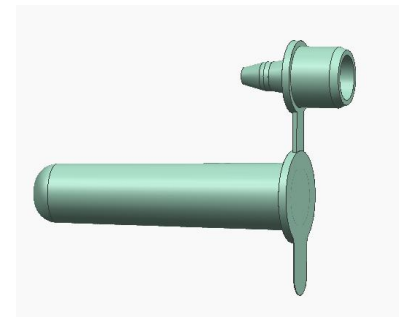
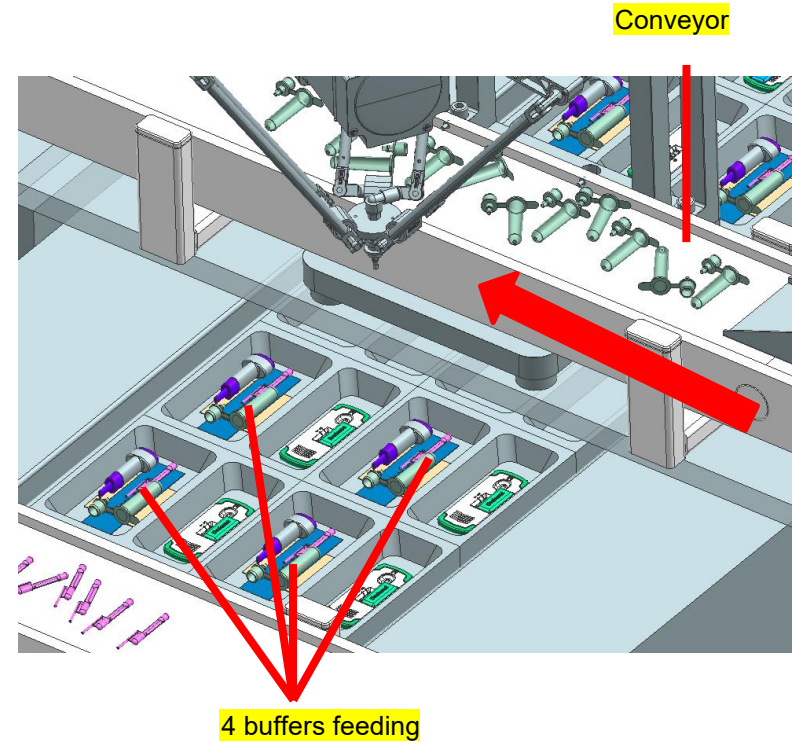
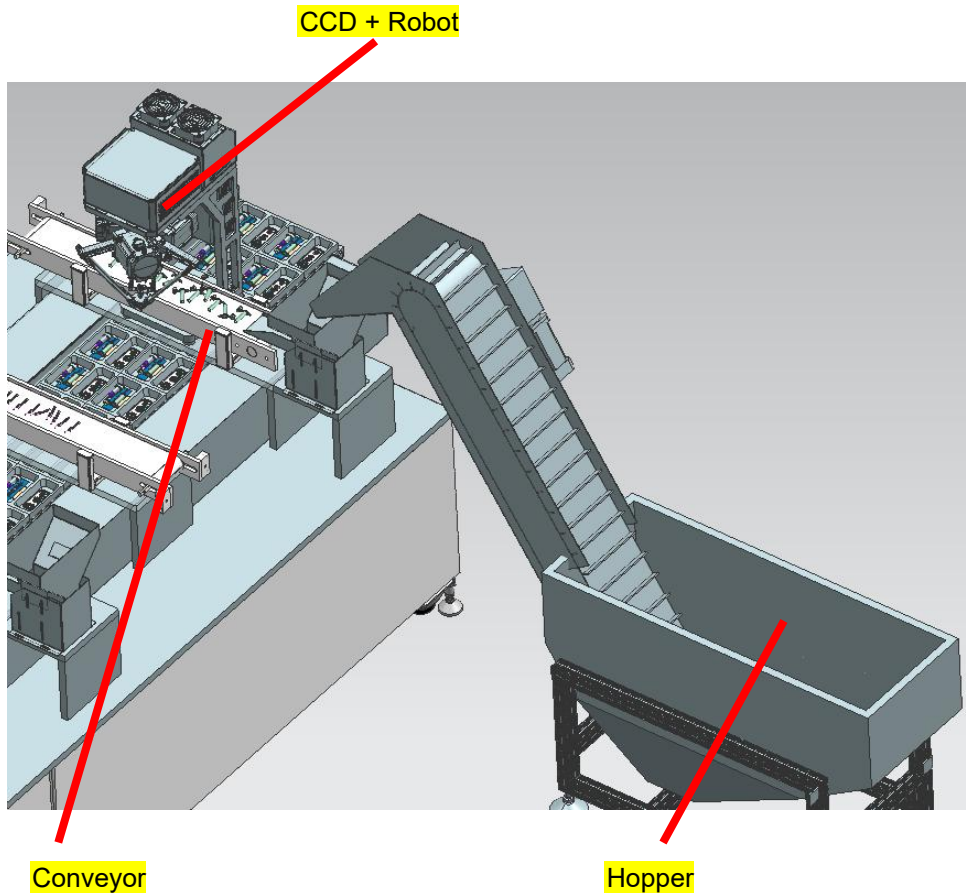

## PART A Rapid Test Kit Packing Machine

### Heat & Seal

Heat & seal

Cover film

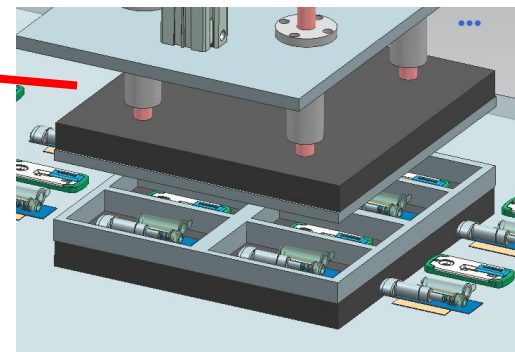
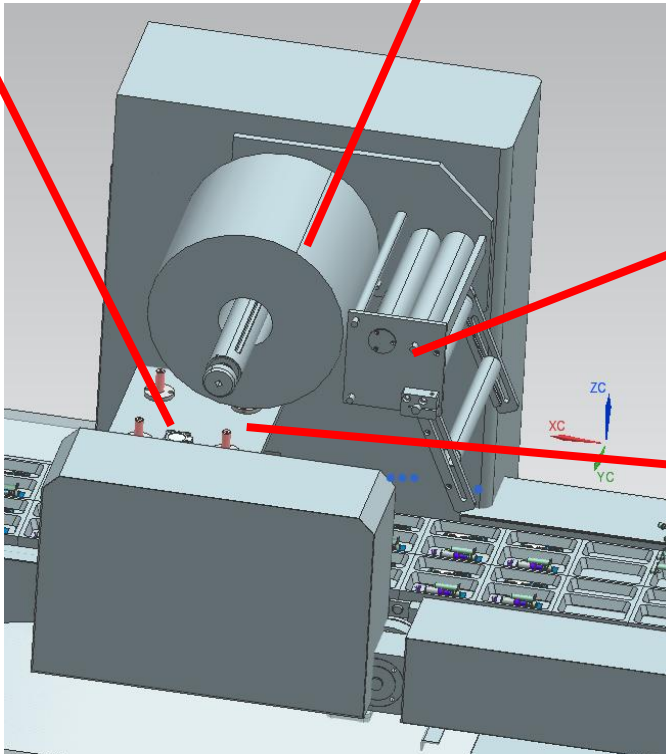



## PART A Rapid Test Kit Packing Machine

### Heat & Seal

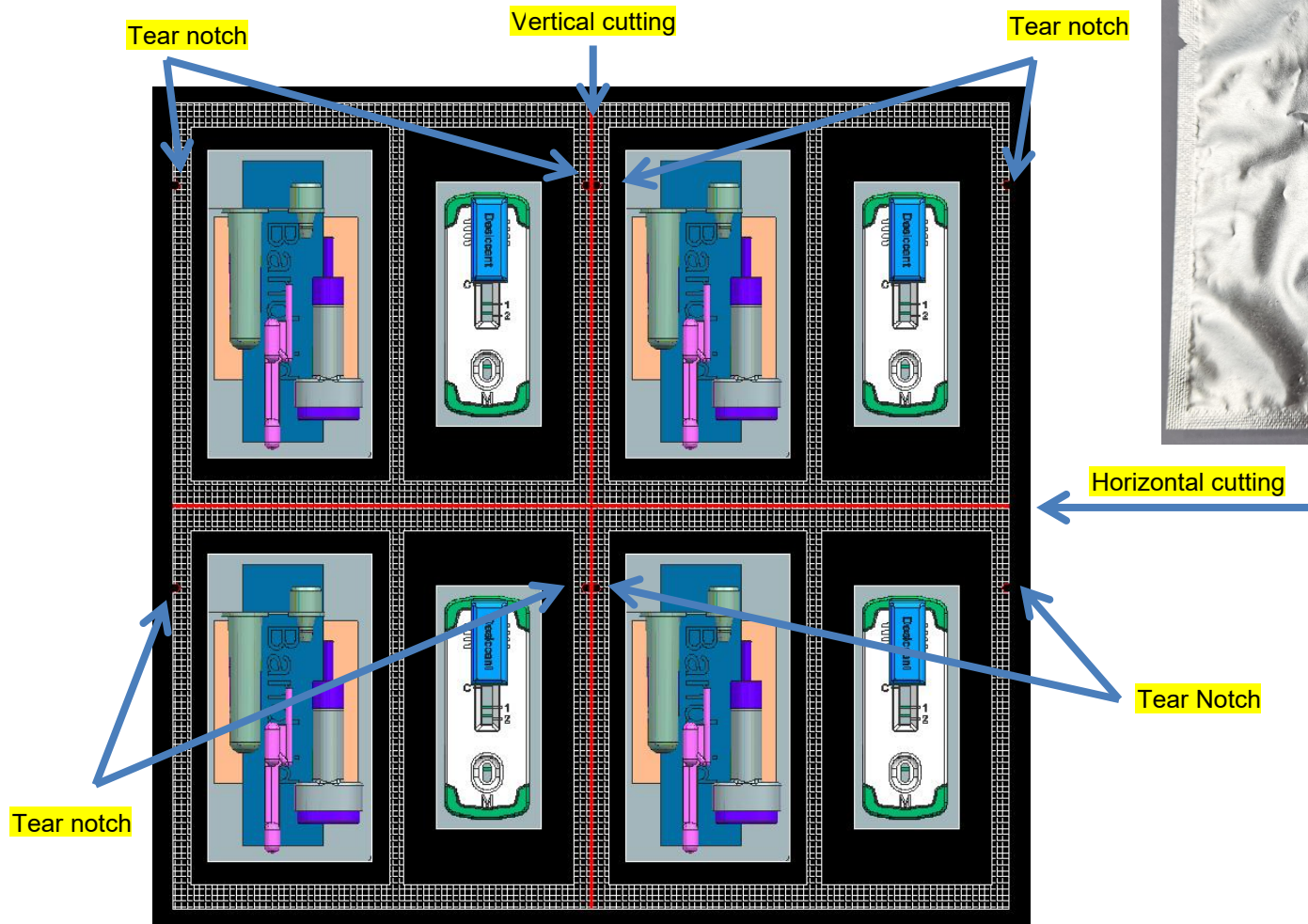

## PART A Rapid Test Kit Packing Machine

### Cooling

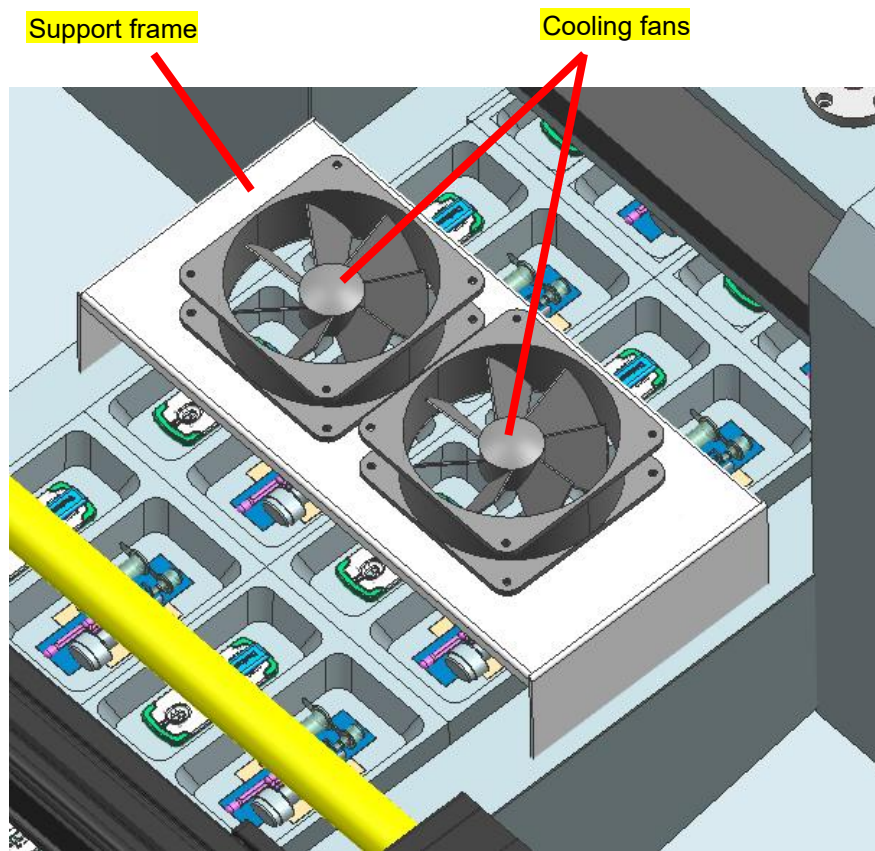



## PART A Rapid Test Kit Packing Machine

### Printer

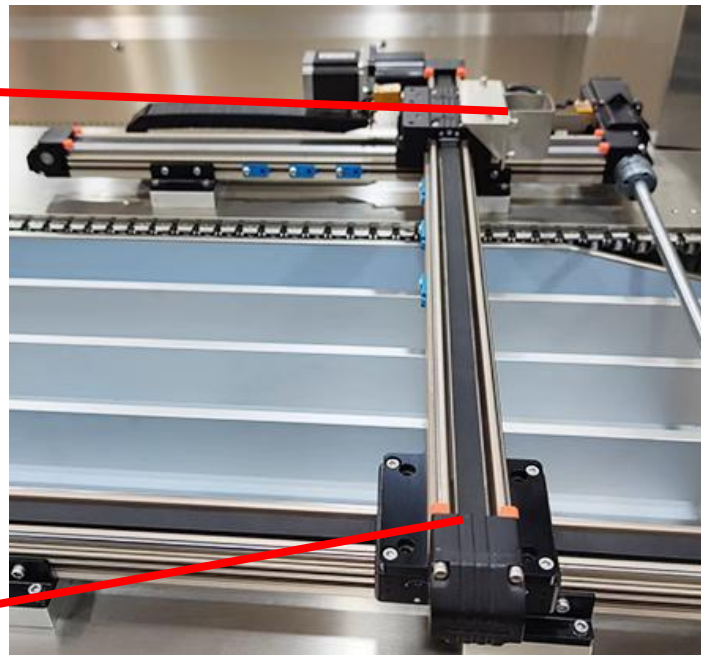
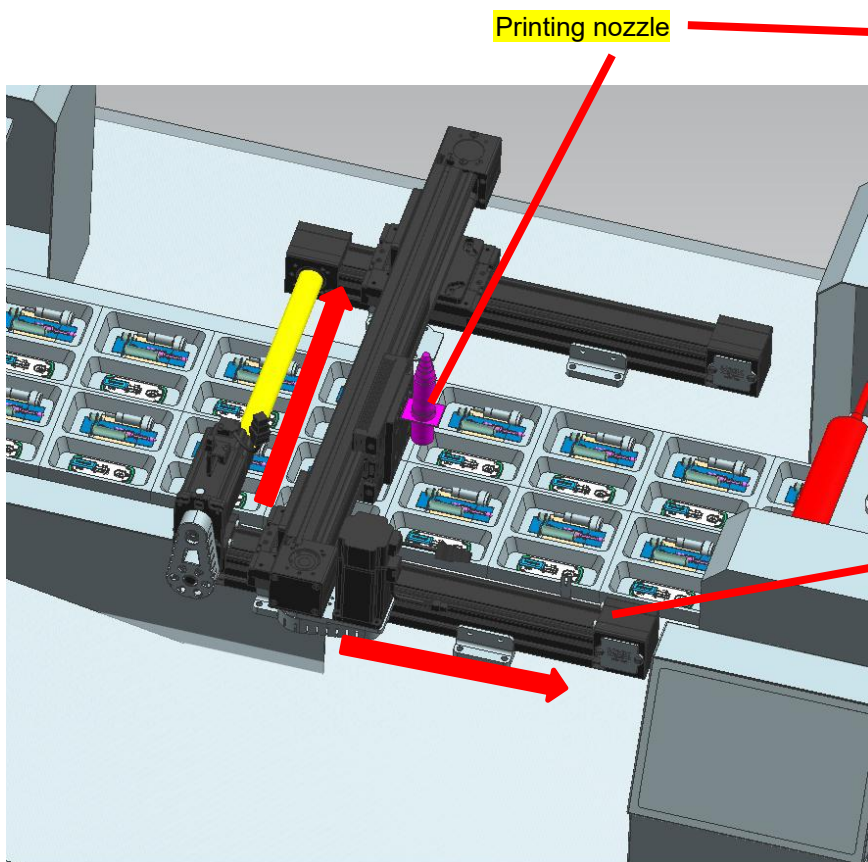

# PART A Rapid Test Kit Packing Machine

## Horizontal cutting

Horizontal & tear notch cutting

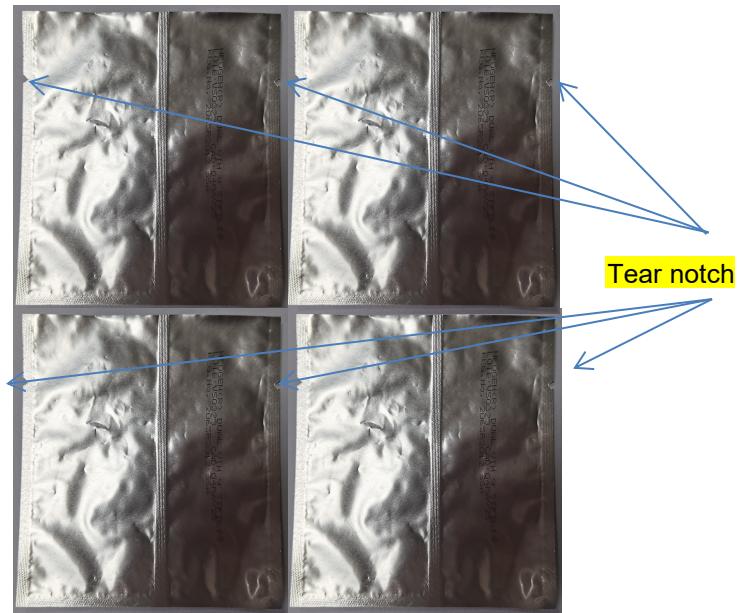
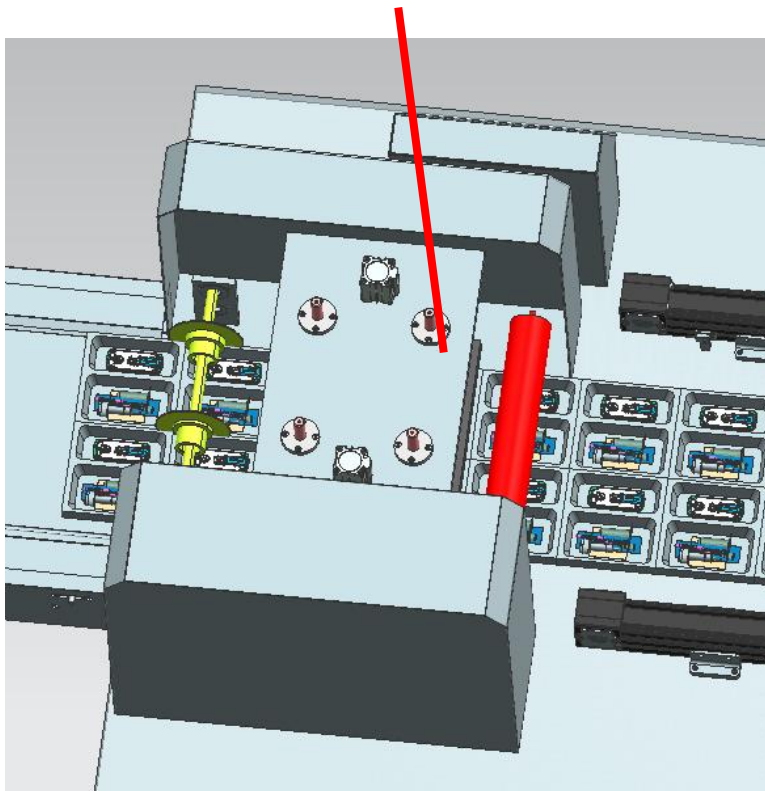

Horizontal cutting

Horizontal cutting

Horizontal cutting

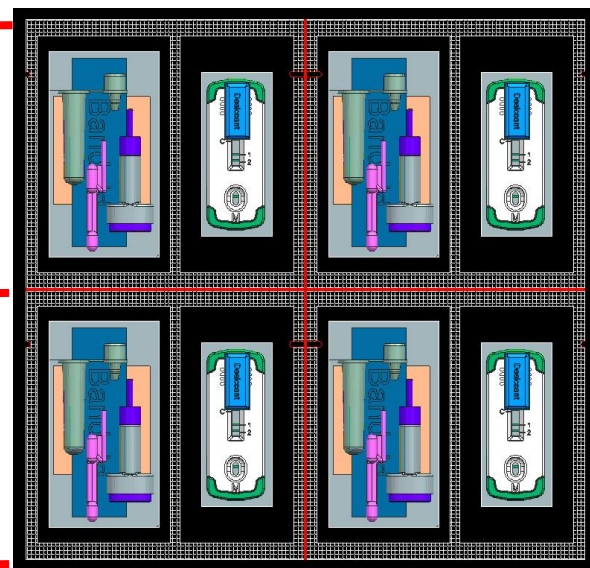

## PART A Rapid Test Kit Packing Machine

### Vertical cutting

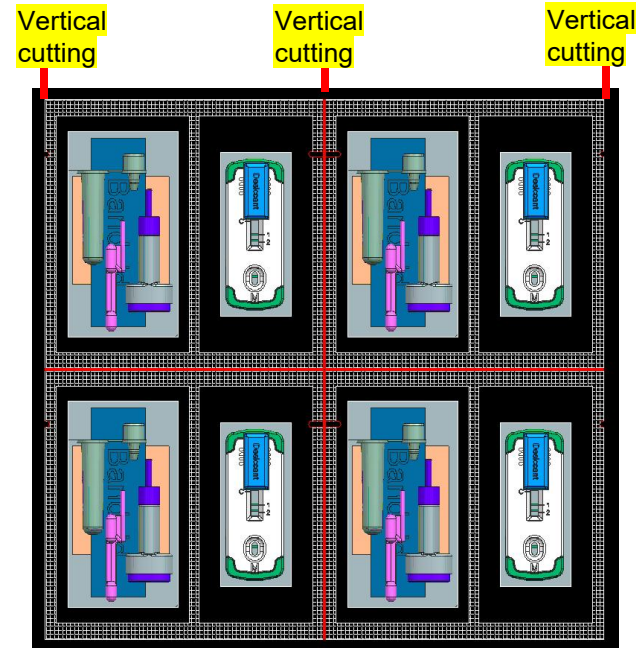
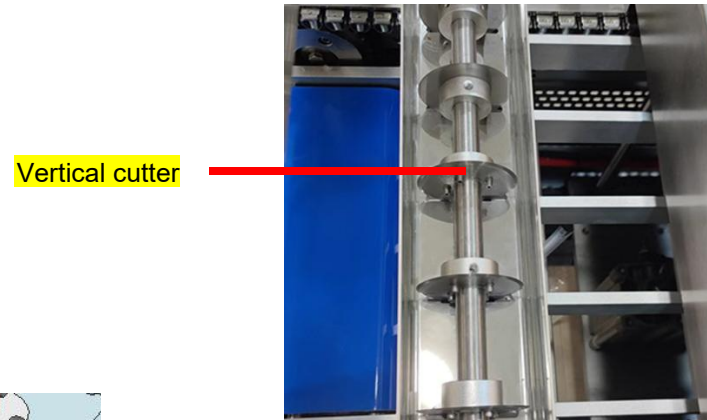
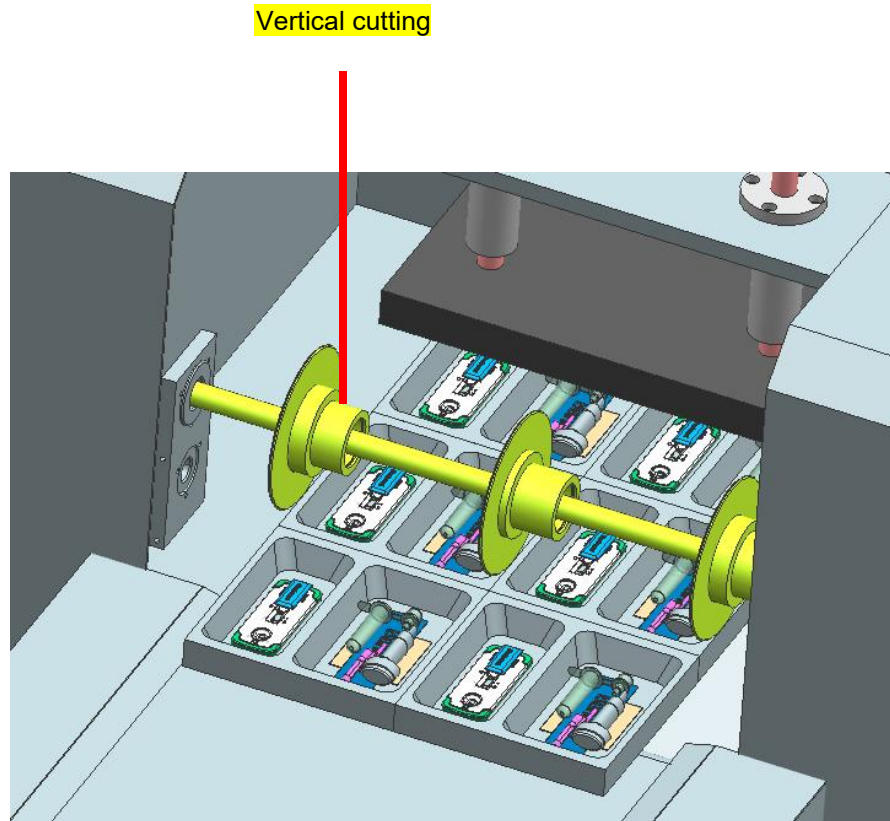



## PART A Rapid Test Kit Packing Machine

### Output

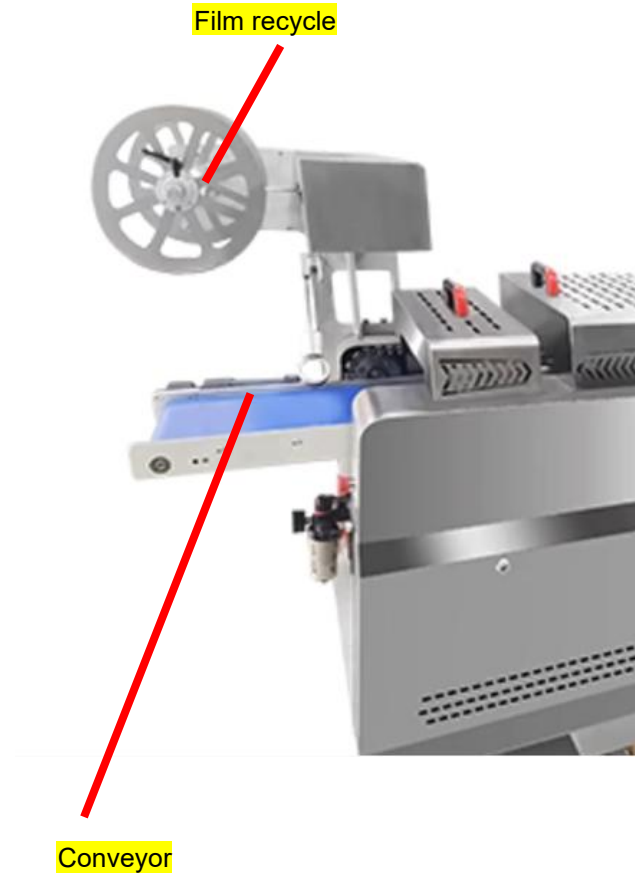
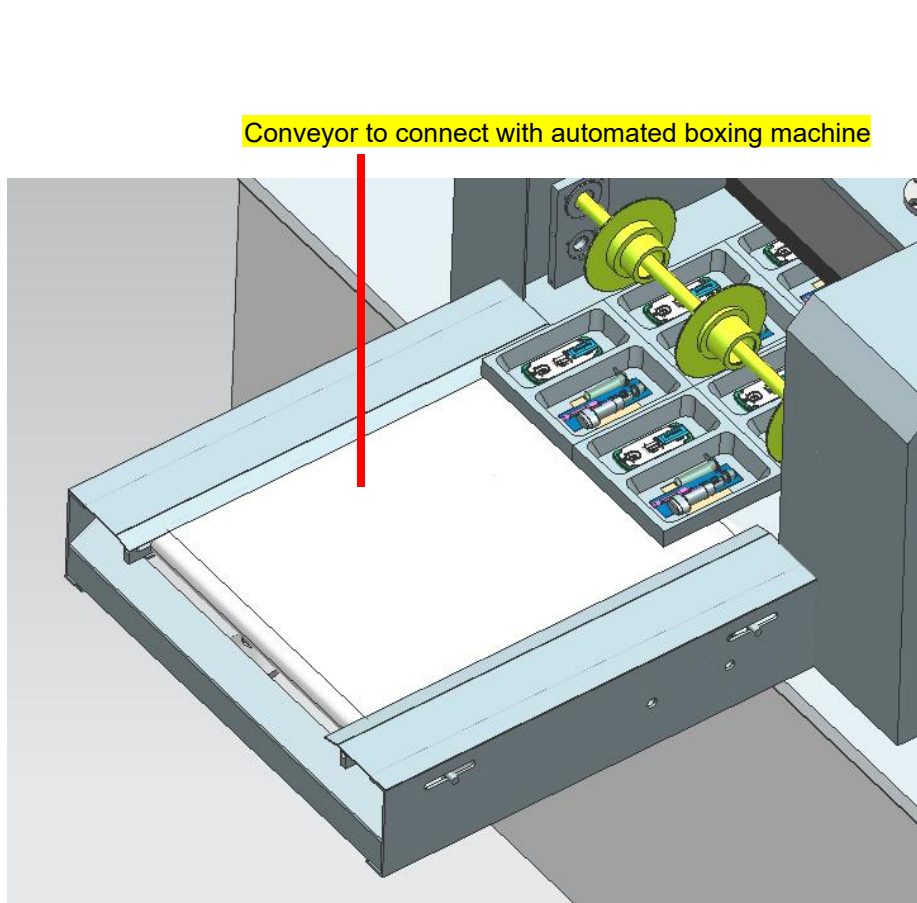

## PART B

### Conveyor for packing machine & boxing machine

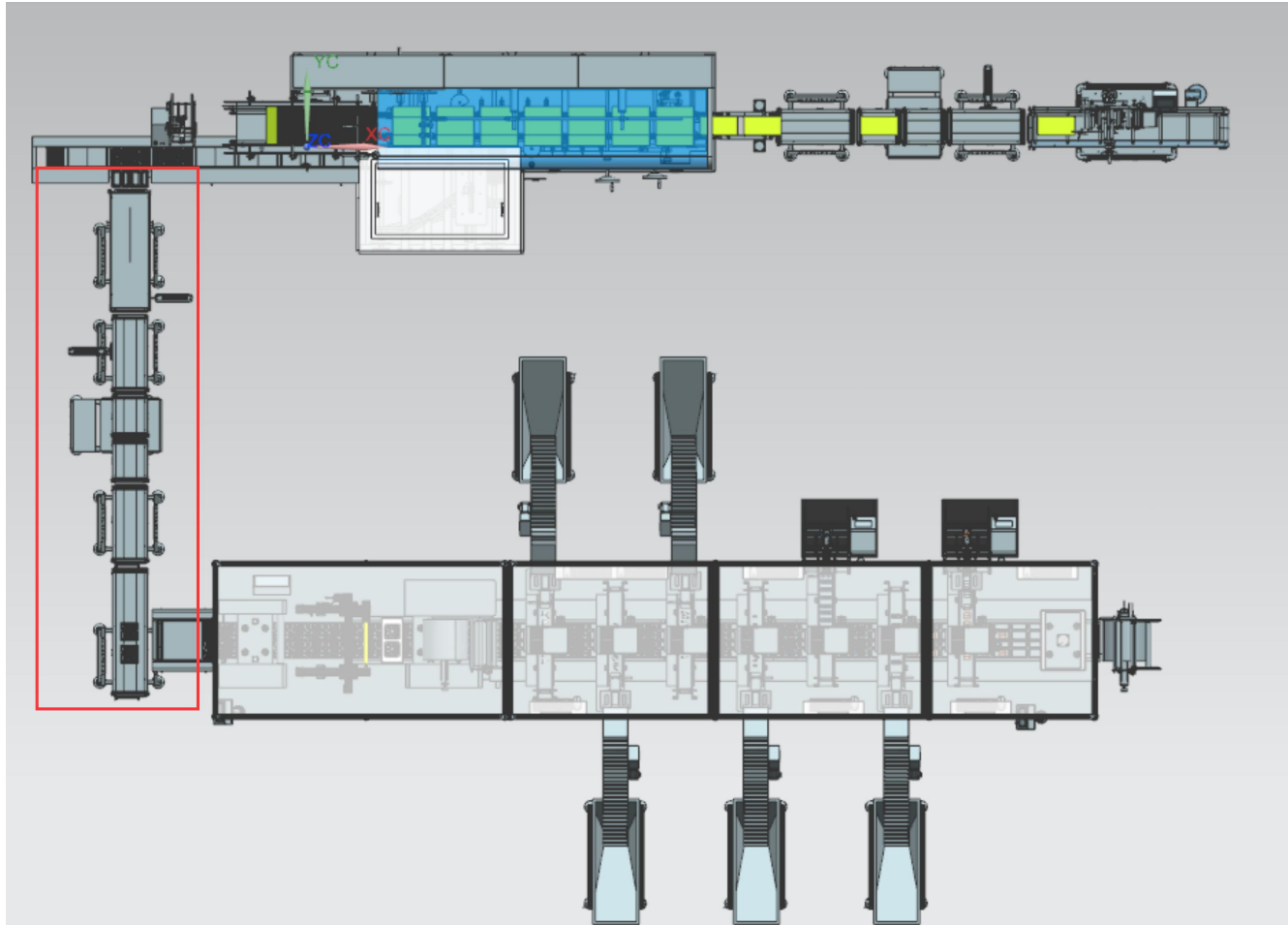



## PART B

### Conveyor for packing machine & boxing machine

#### Overview

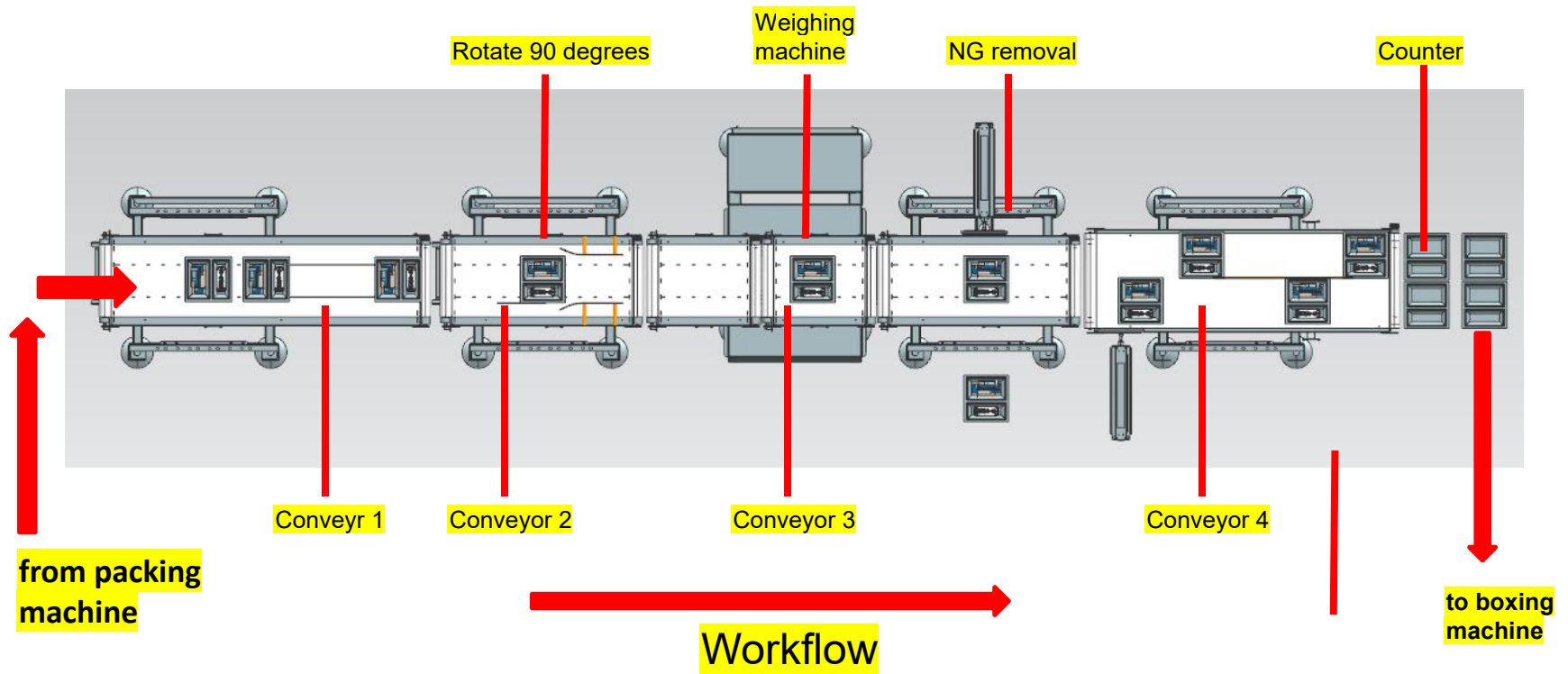

## PART B

### Conveyor for packing machine & boxing machine

#### Dimension

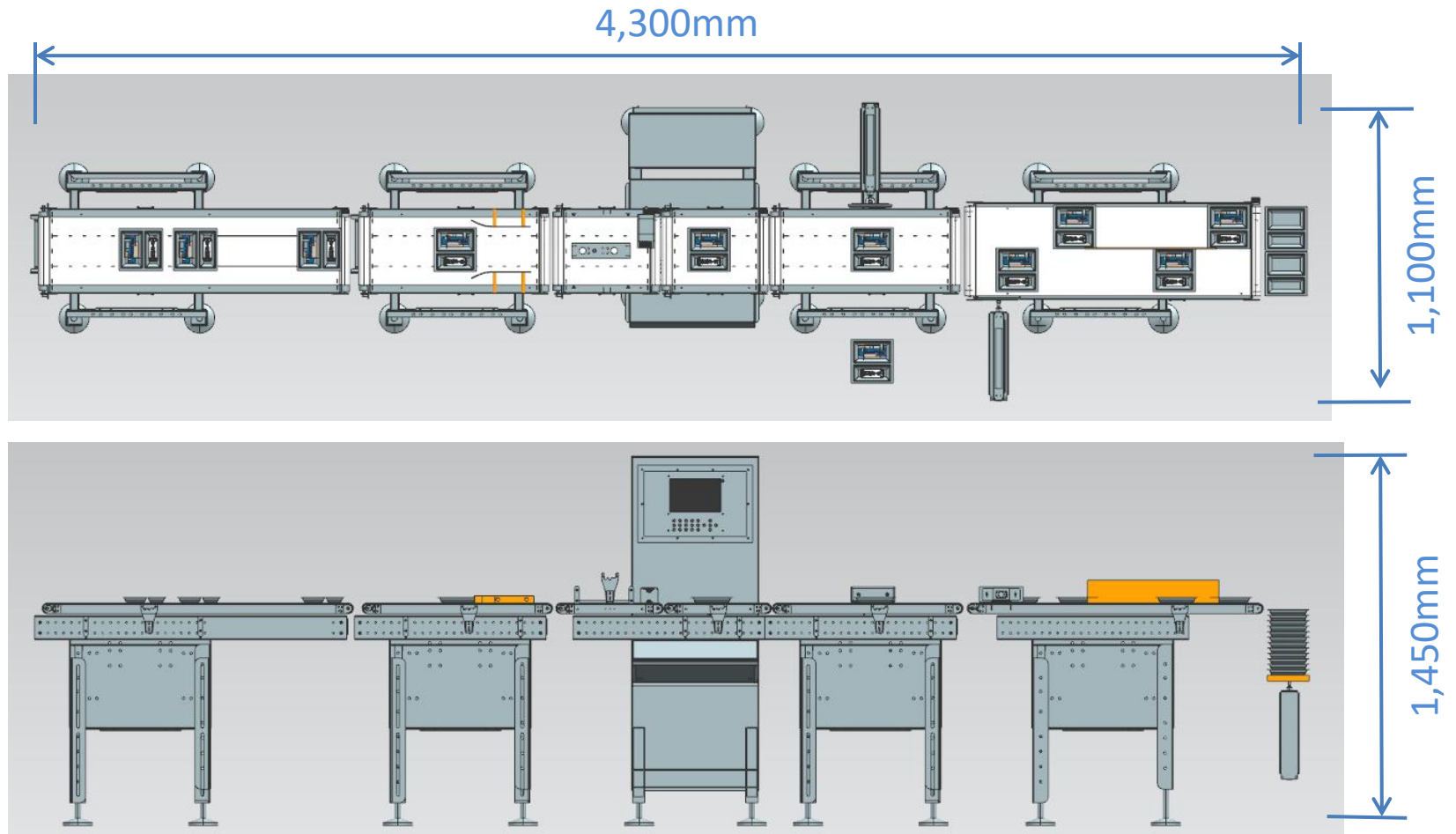

## PART C Automated Boxing Machine

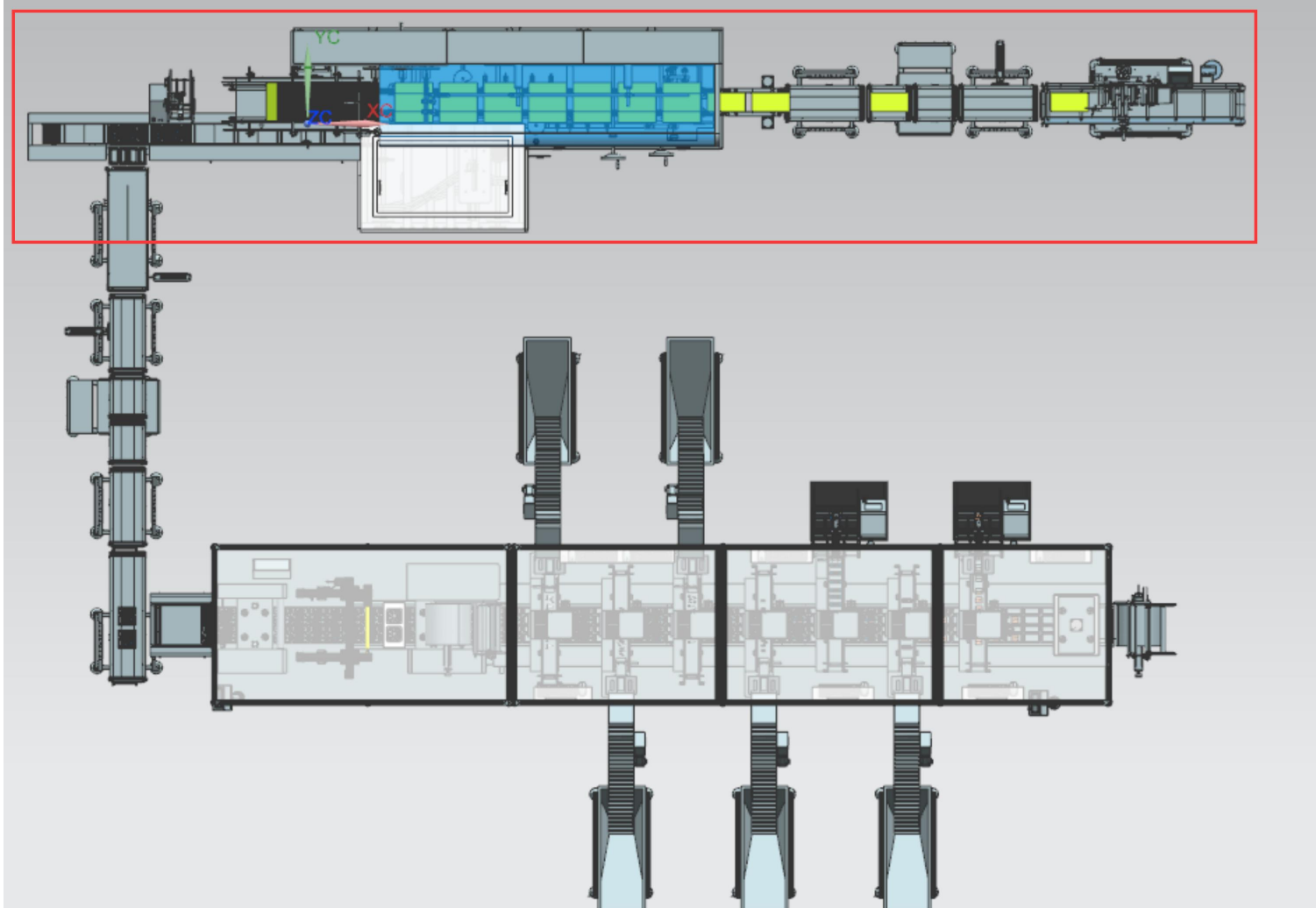

## PART C Automated Boxing Machine

25 Pouches/box

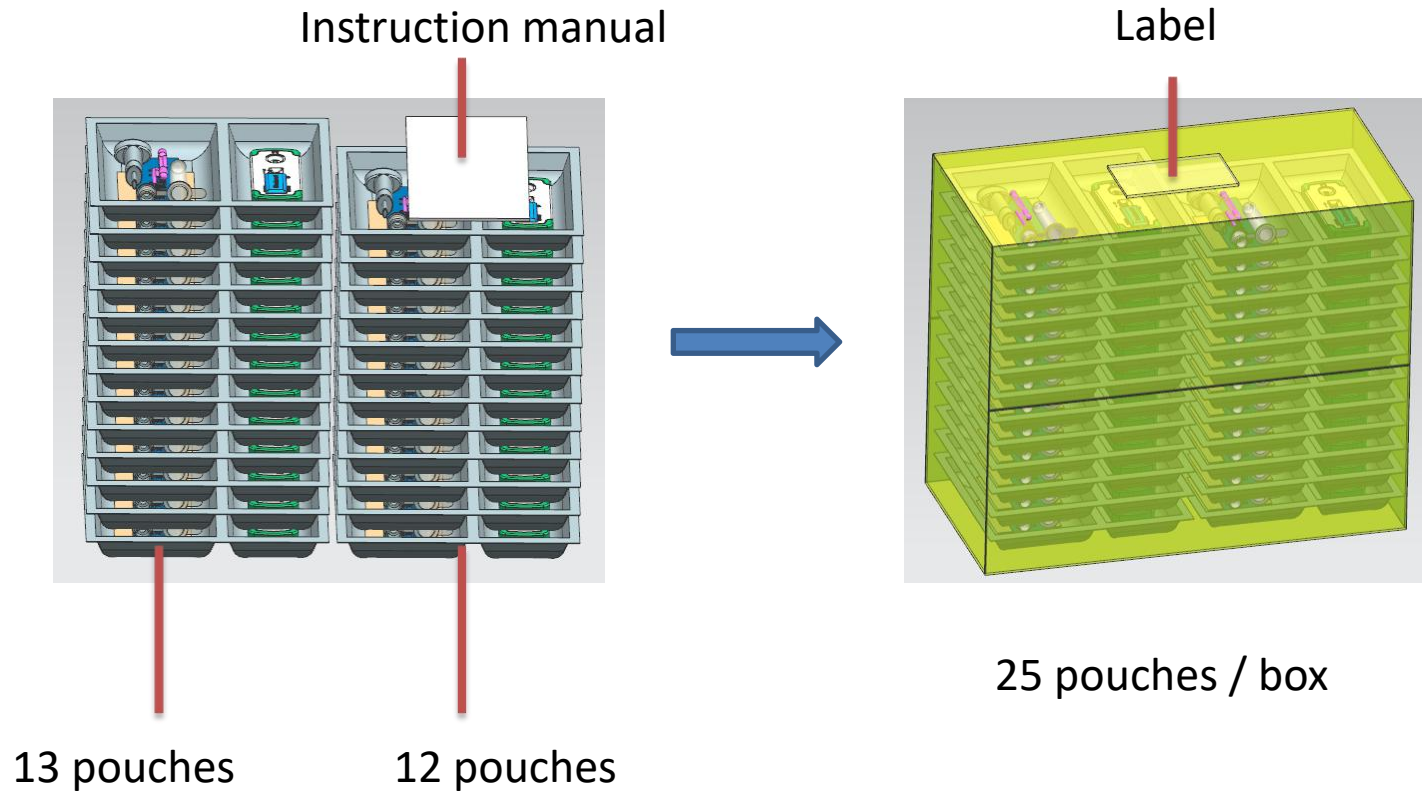



## PART C Automated Boxing Machine

### Box Size

**Paper thickness: 1.50 (mm)**

**Box size: L300\*W240\*H145 (mm)**

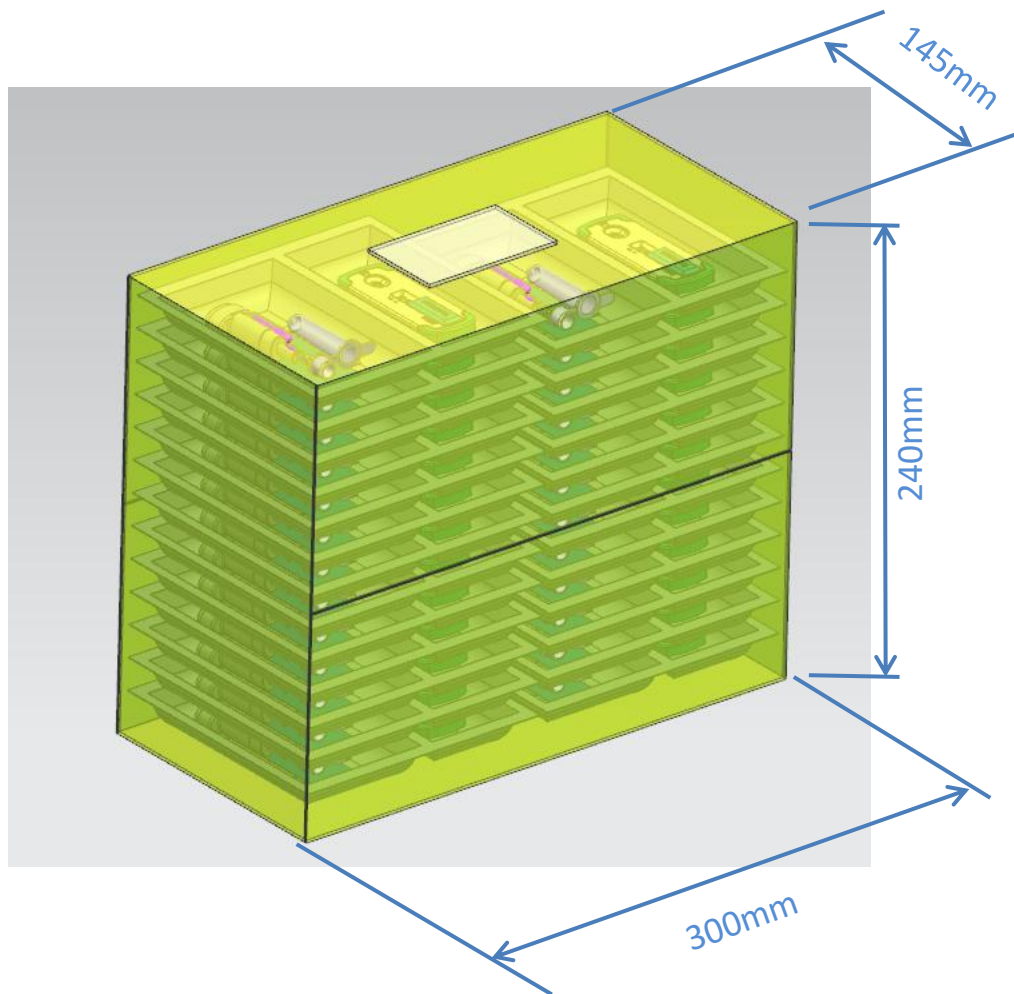

## PART C Automated Boxing Machine

### Overview

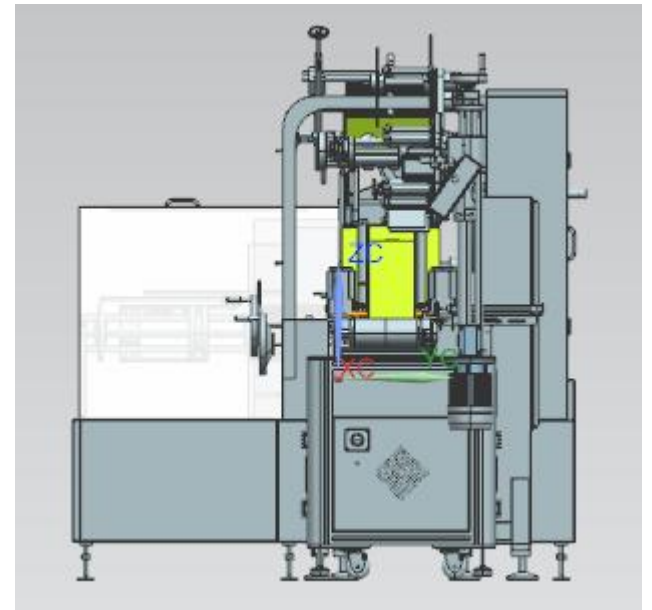
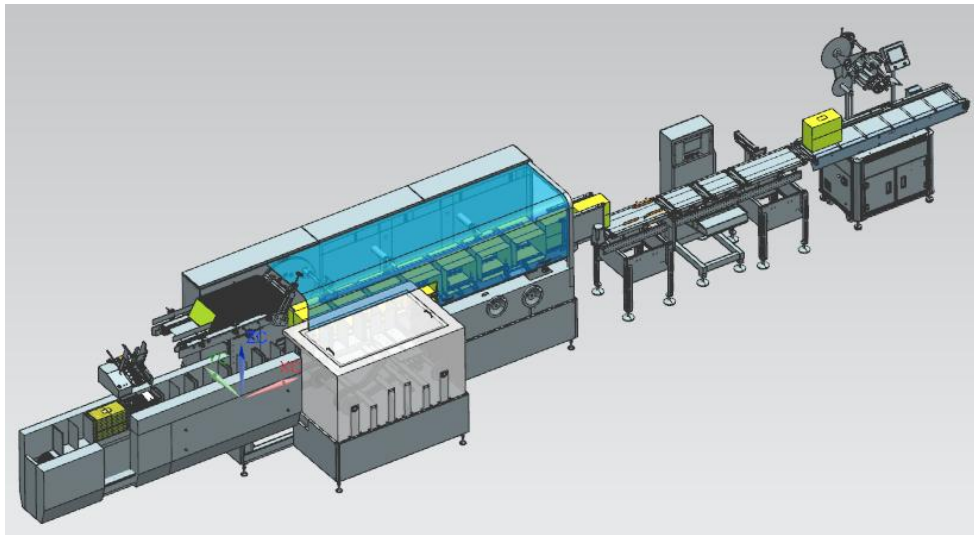
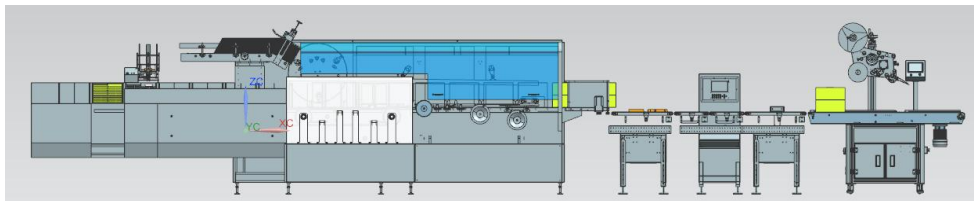
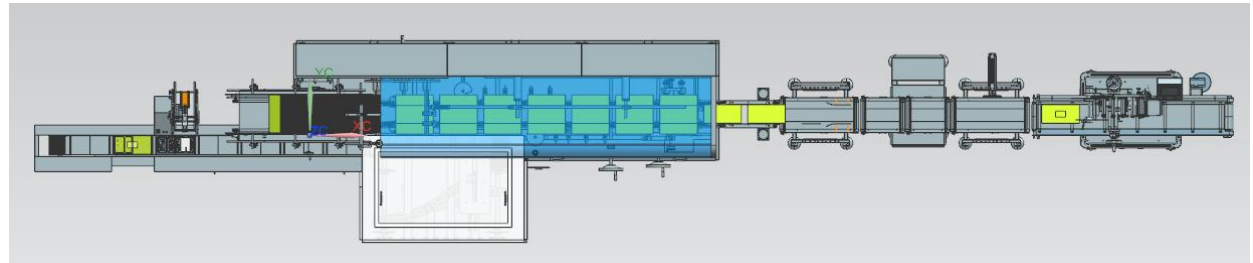

## PART C Automated Boxing Machine

### Dimension

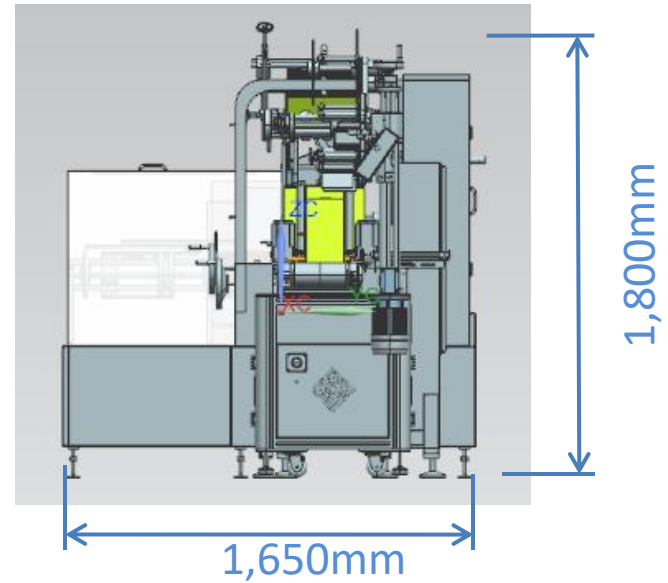
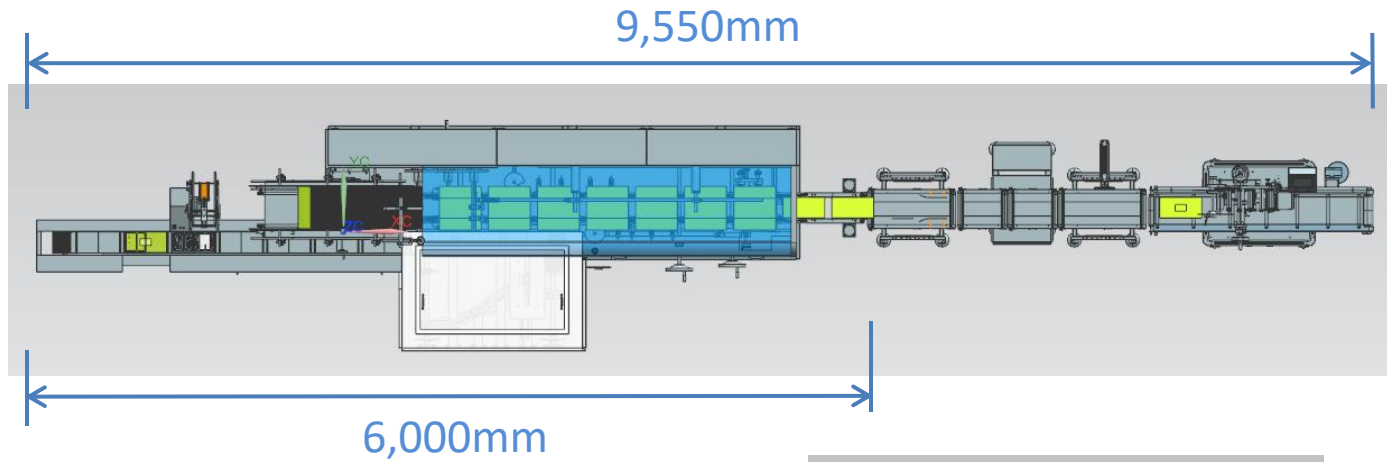

## PART C Automated Boxing Machine

### Workstaions

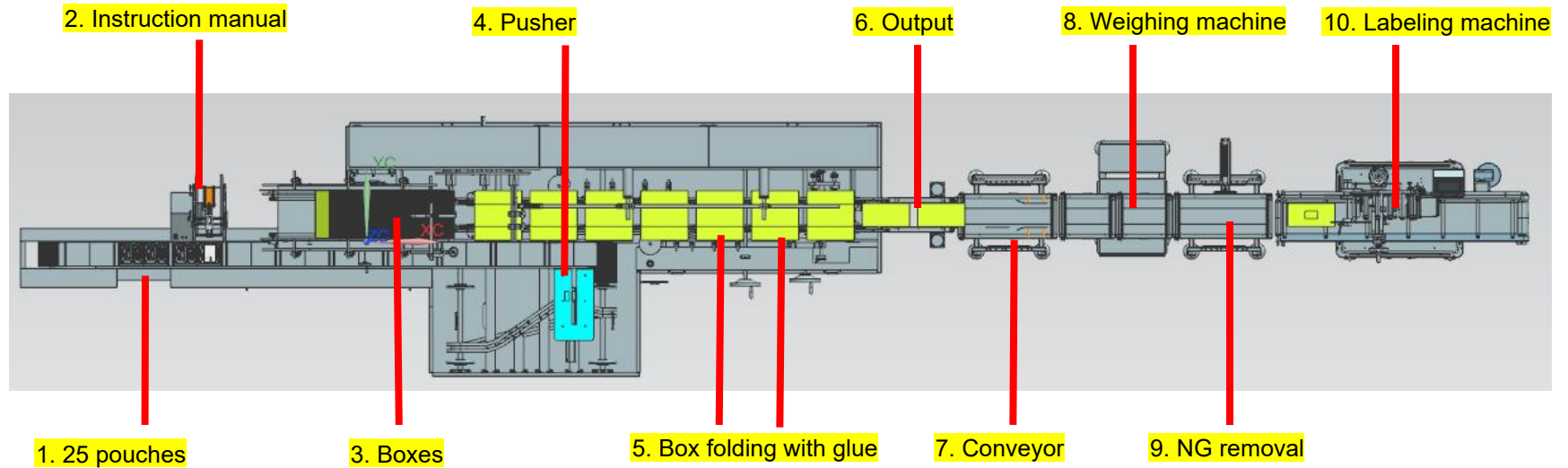



## PART C Automated Boxing Machine

### Pouches & instruction manual feeder

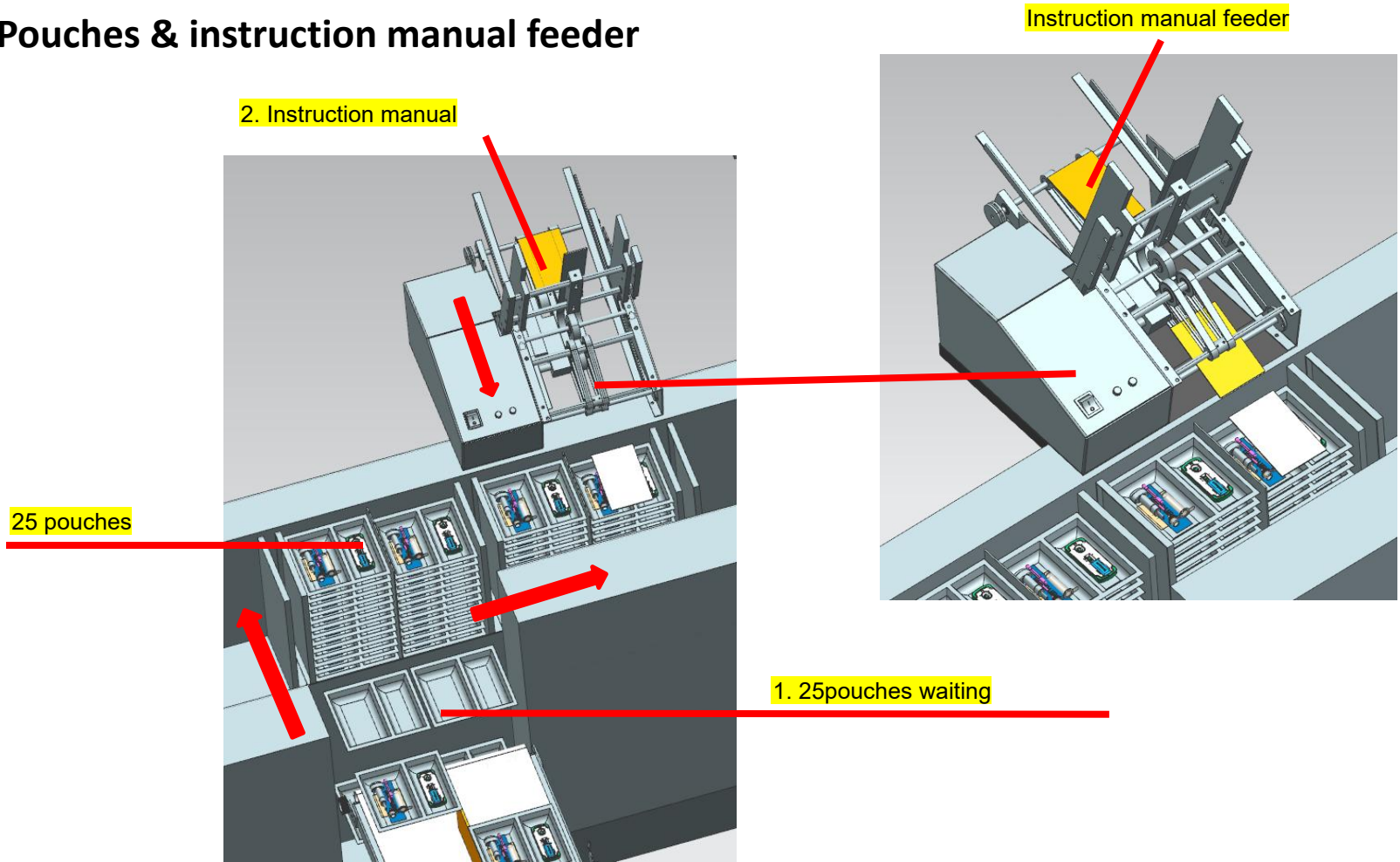

## PART C Automated Boxing Machine

### Boxes feeder

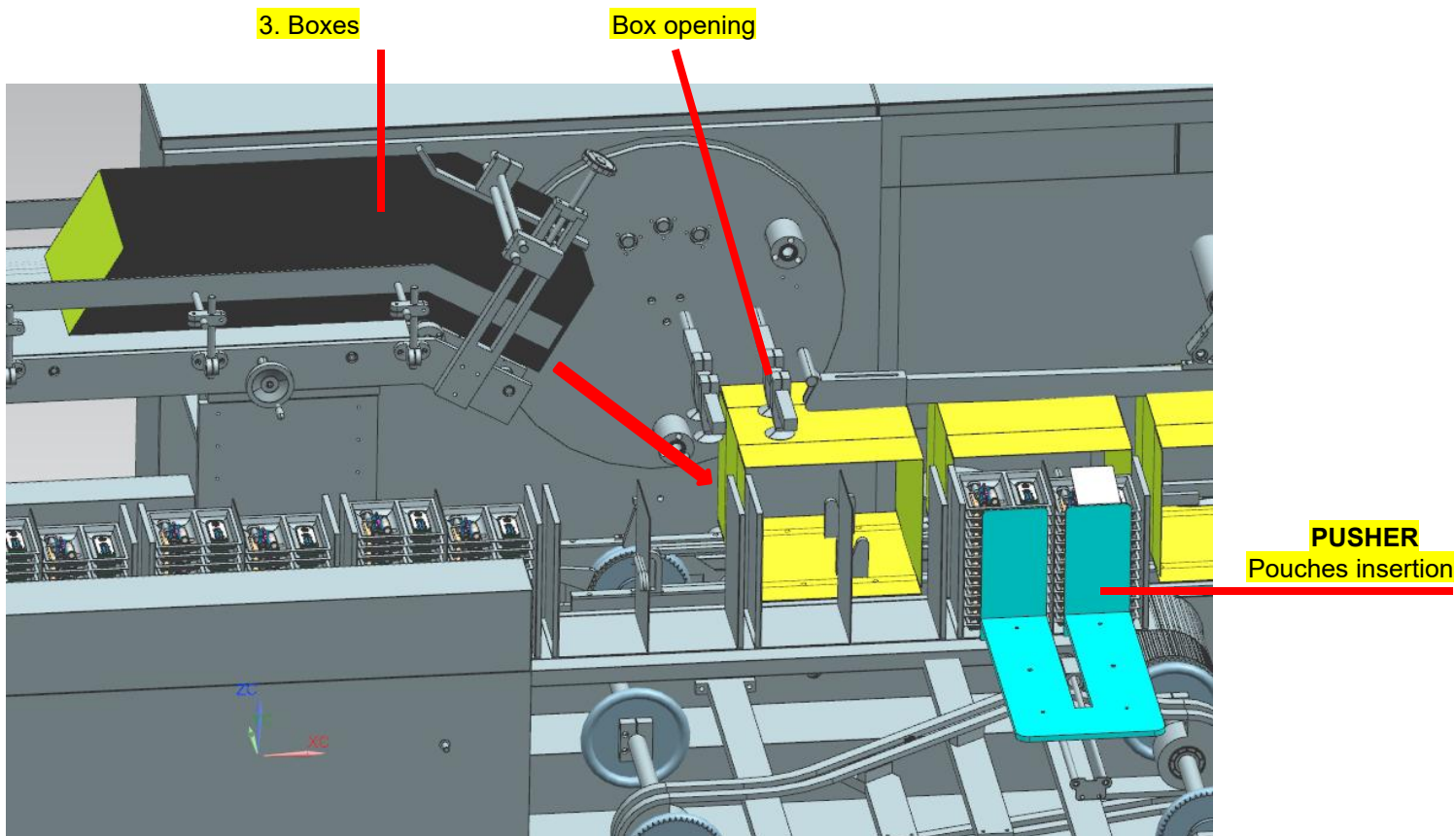

## PART C Automated Boxing Machine

### Box folding & glue dispensing

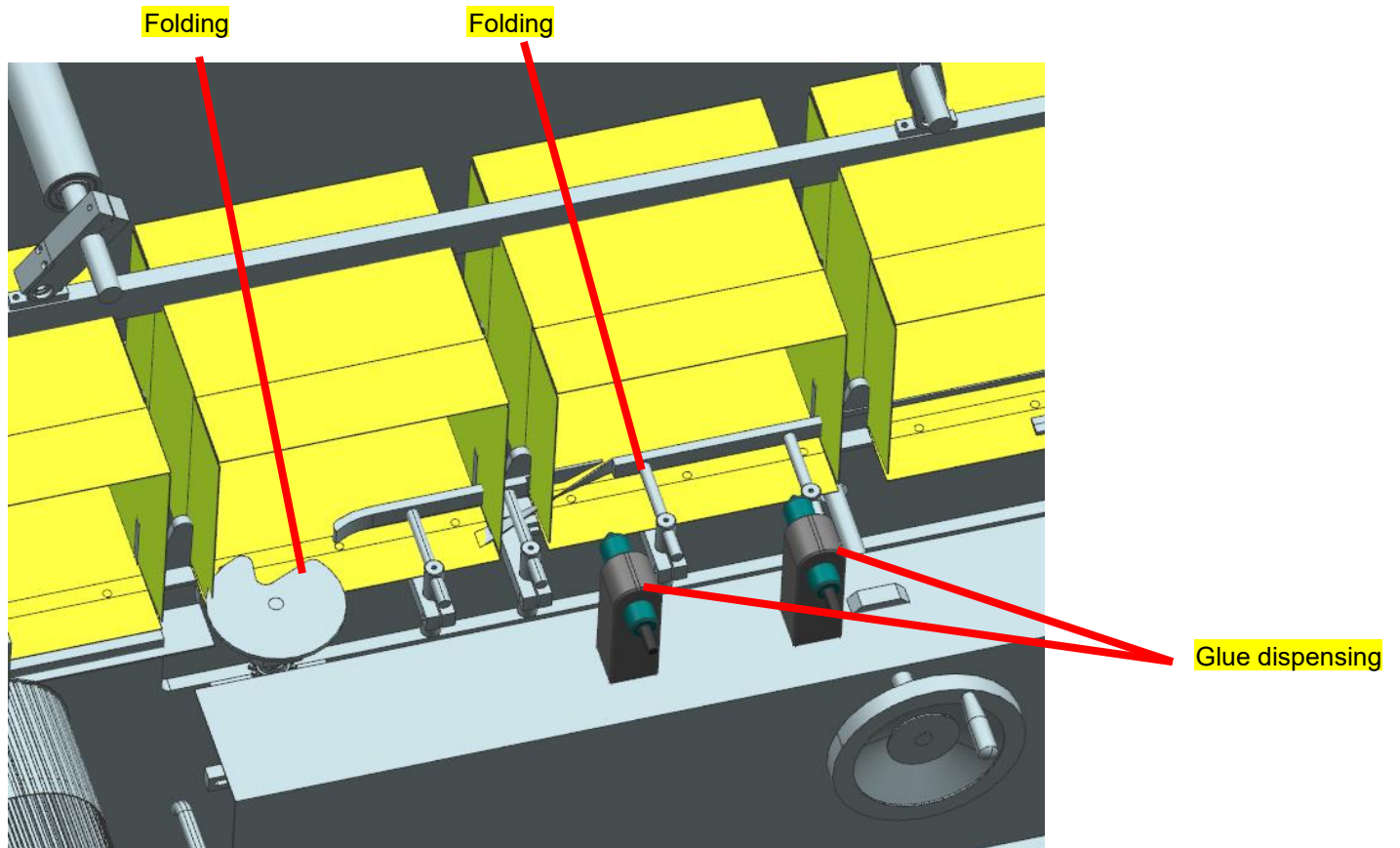

## PART C Automated Boxing Machine

### Output

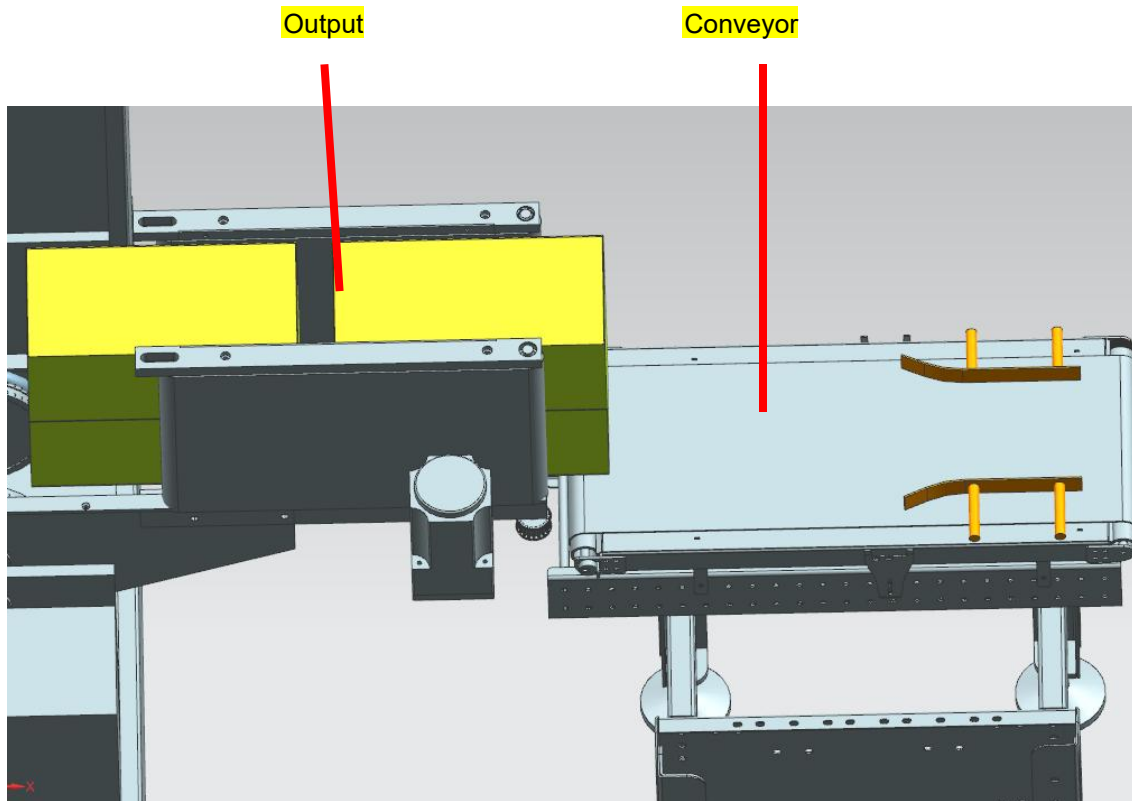



## PART C Automated Boxing Machine

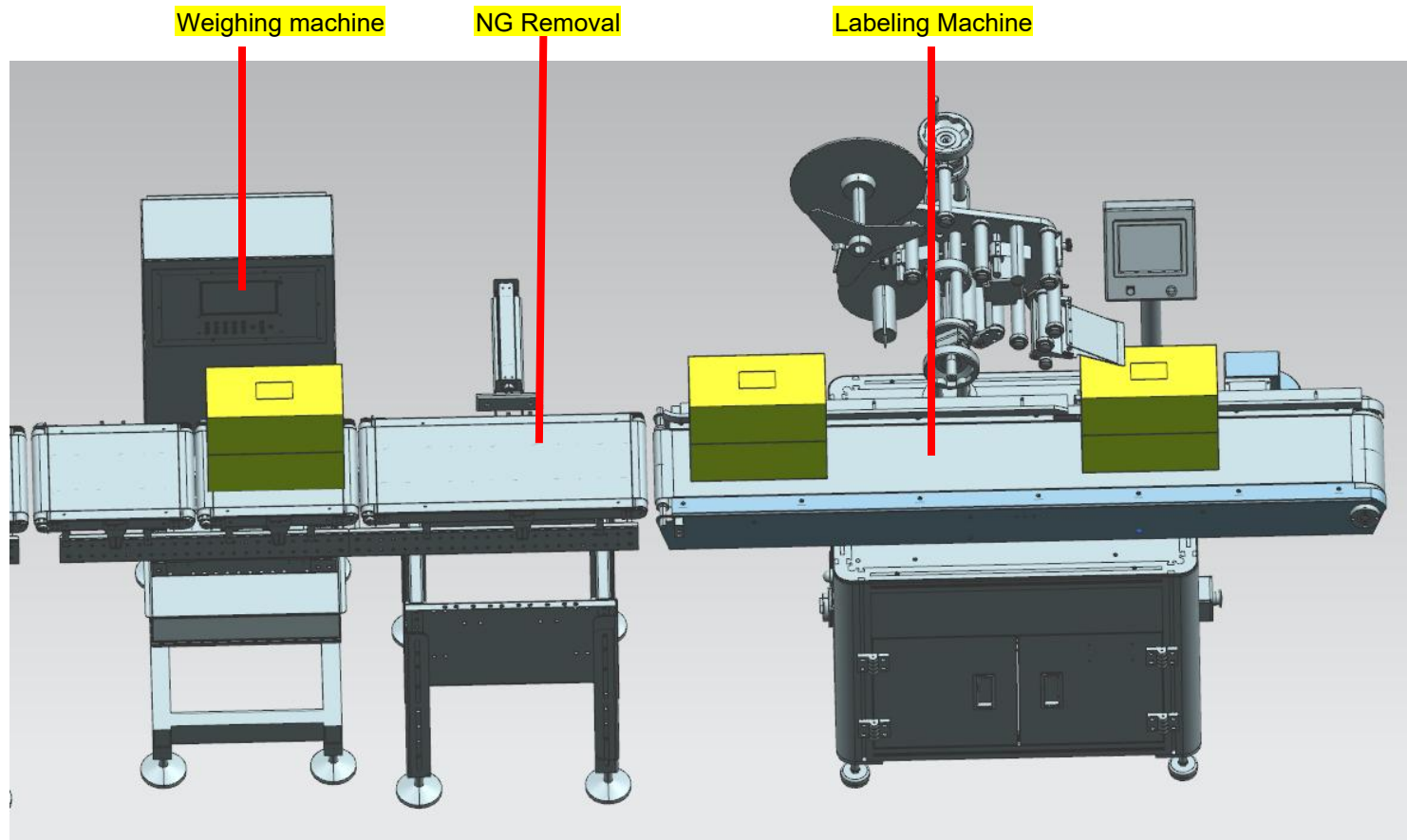

## **Rapid Test Kit Packing Machine + Automated Boxing Machine**

### **Features:**

1. Touch screen
2. Capacity: 3,600 bags/hour
3. Fully automation
4. Easy to use

### **Operation:**

1. Connect power supply and air supply
2. Place materials into hopper
3. Install back film and cover film
4. Start running

## Rapid Test Kit Packing Machine + Automated Boxing Machine

Parameters	
Capacity	3,600 bags/H
Activation	85%
Air supply	0.5~0.8MPa
Power supply	AC220V/50Hz
Internal power	DC/24V
Power	18 KW
Weight	6000kg
Dimension	L9.55 * W7.0 * H1.8m
CCD + Robots	7 sets

## Rapid Test Kit Packing Machine + Automated Boxing Machine

Key components	
PLC	Mitsubishi/Panasonic
Operation system	ANTITECK
Servo	Inovance/KNK
Relay	Schneider/CHNT
Sensor	OMRON/Panasonic
Cylinder	SMC/AIRTAC
Solenoid valve	SMC/AIRTAC
Connector	SMC/AIRTAC