

# Rapid Test Strip Packaging Machine

Test strip + desiccant + normal foil bag

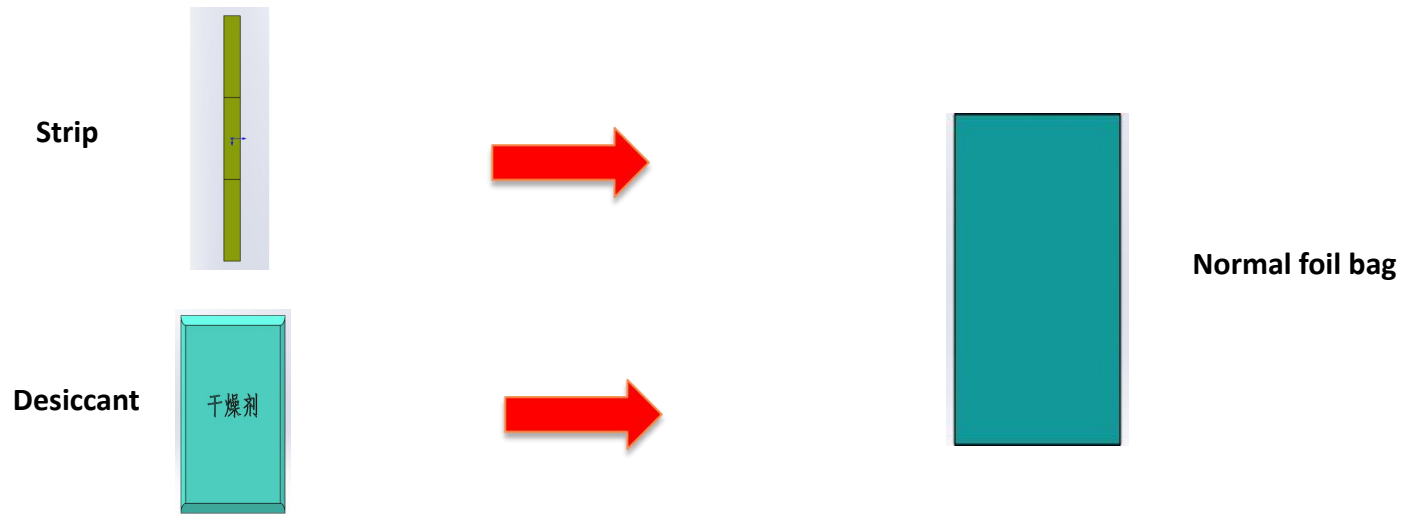

## Workflow:

1. Automatic feeding foil bag
2. Manual feeding strips
3. Automatic feeding desiccant bag
4. Automatic open foil bag
5. Automatic insert strip and desiccant into foil bag
6. Automatic seal foil bag
7. Finish

# Rapid Test Strip Packaging Machine

Test strip + desiccant + normal foil bag

## Overview



Font view

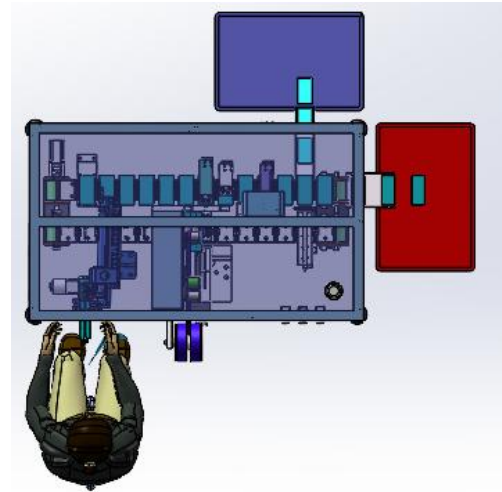

Top view

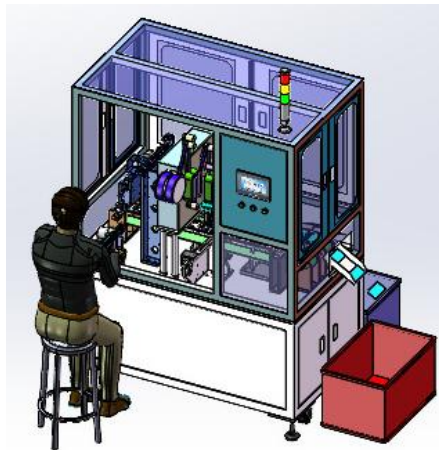

Side view

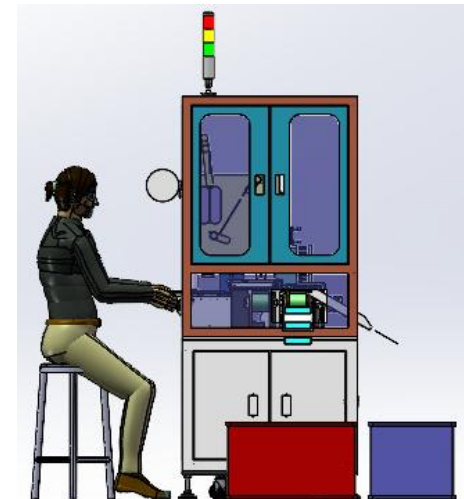

Right view

# Rapid Test Strip Packaging Machine

Test strip + desiccant + normal foil bag

## Dimension

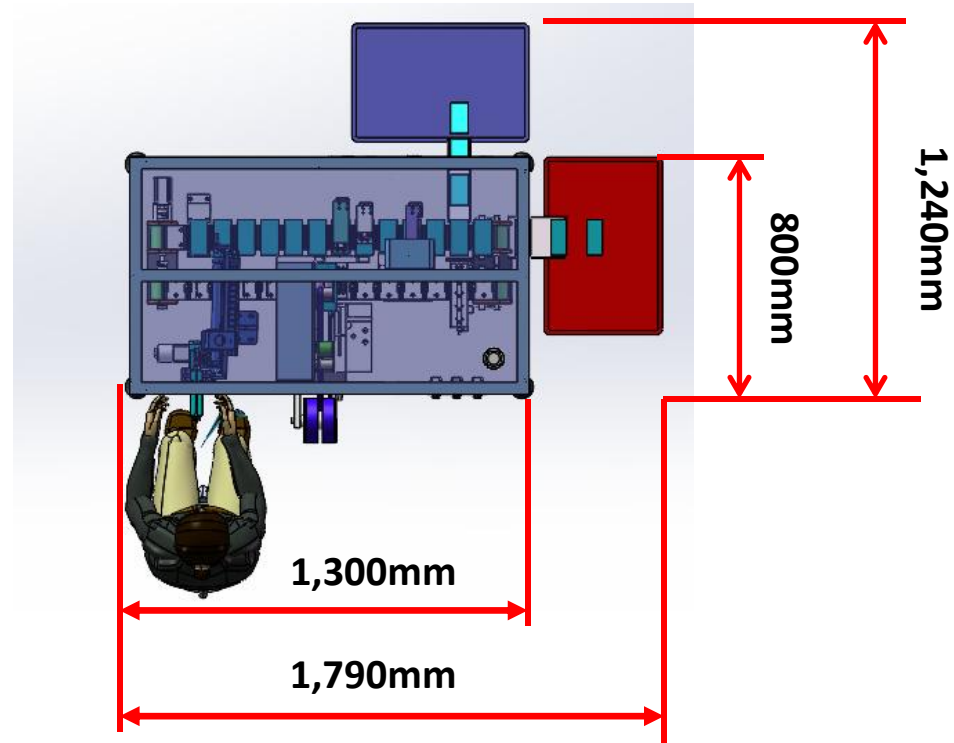

# Rapid Test Strip Packaging Machine

Test strip + desiccant + normal foil bag

## Workstations

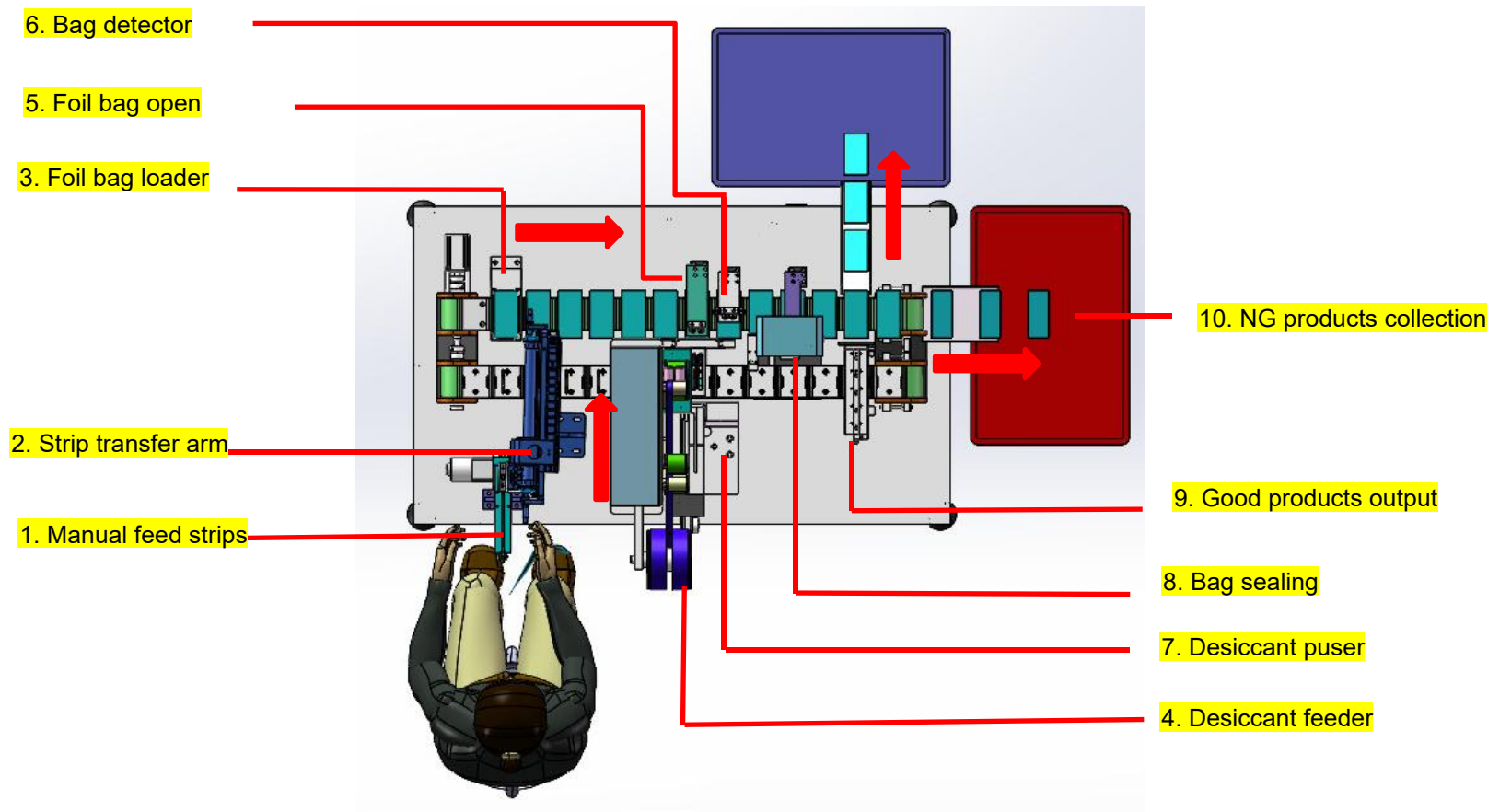

# Rapid Test Strip Packaging Machine

Test strip + desiccant + normal foil bag

## Manual strip feeding

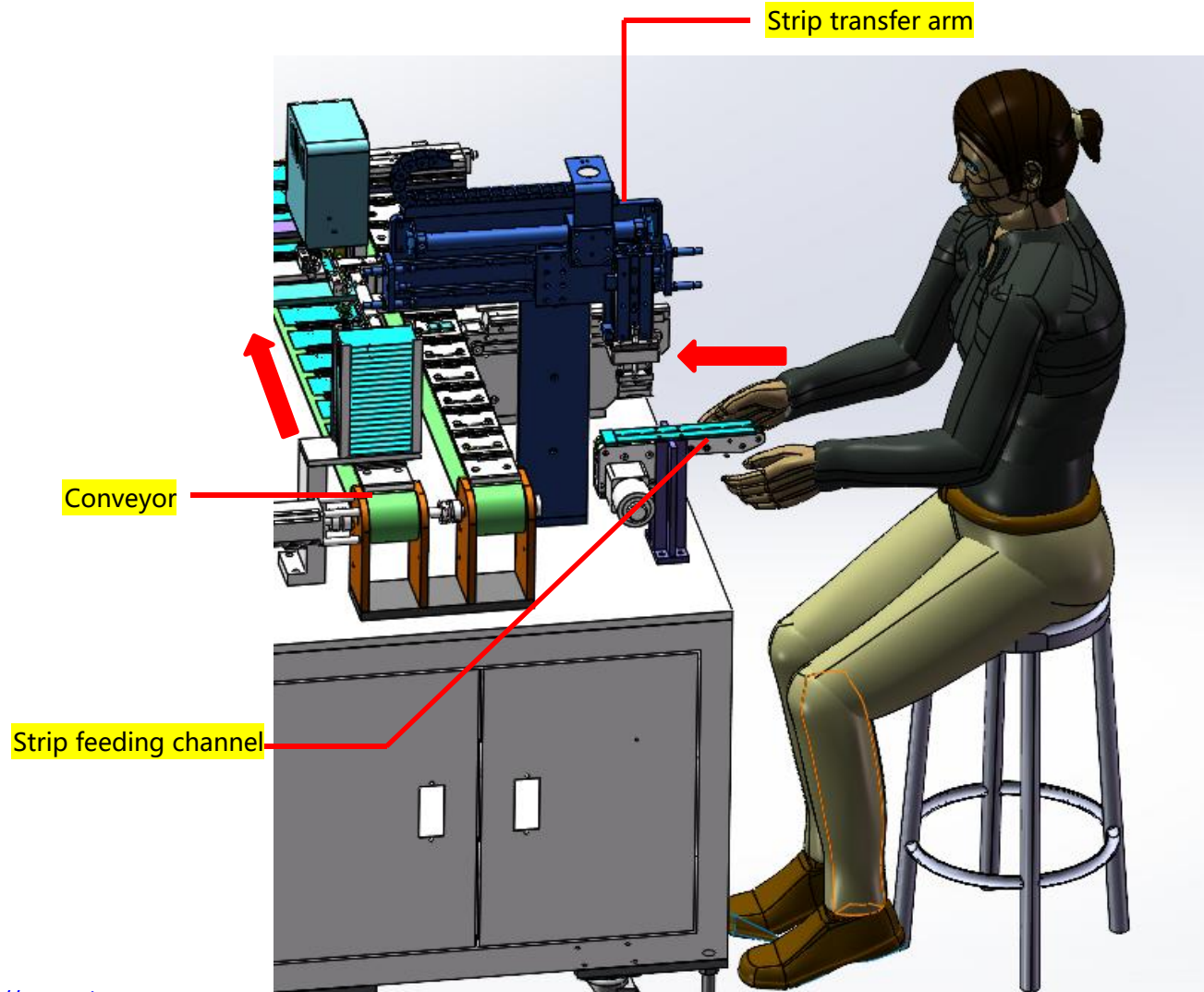

# Rapid Test Strip Packaging Machine

Test strip + desiccant + normal foil bag

## Foil bag feeding

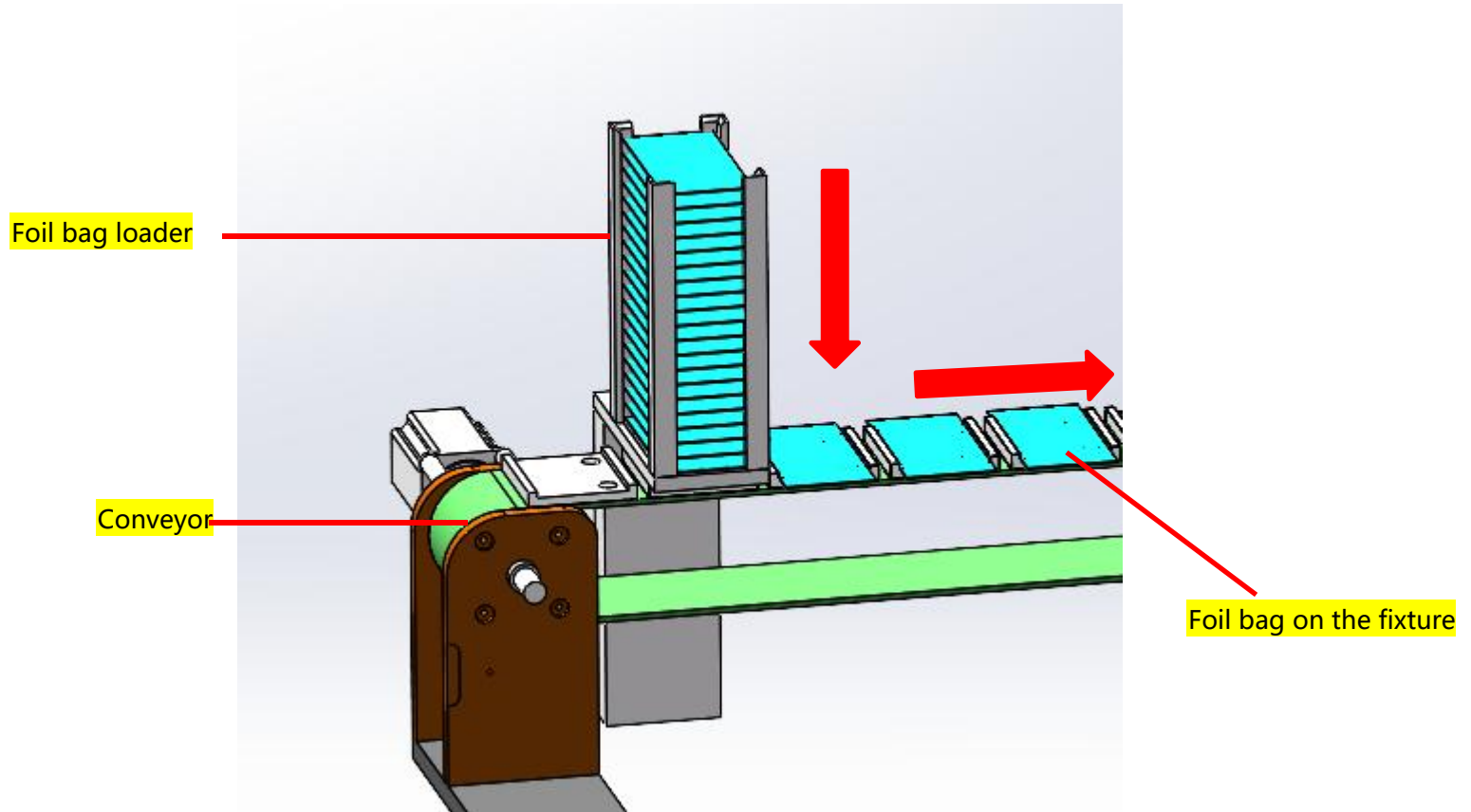

# Rapid Test Strip Packaging Machine

Test strip + desiccant + normal foil bag

## Desiccant feeder

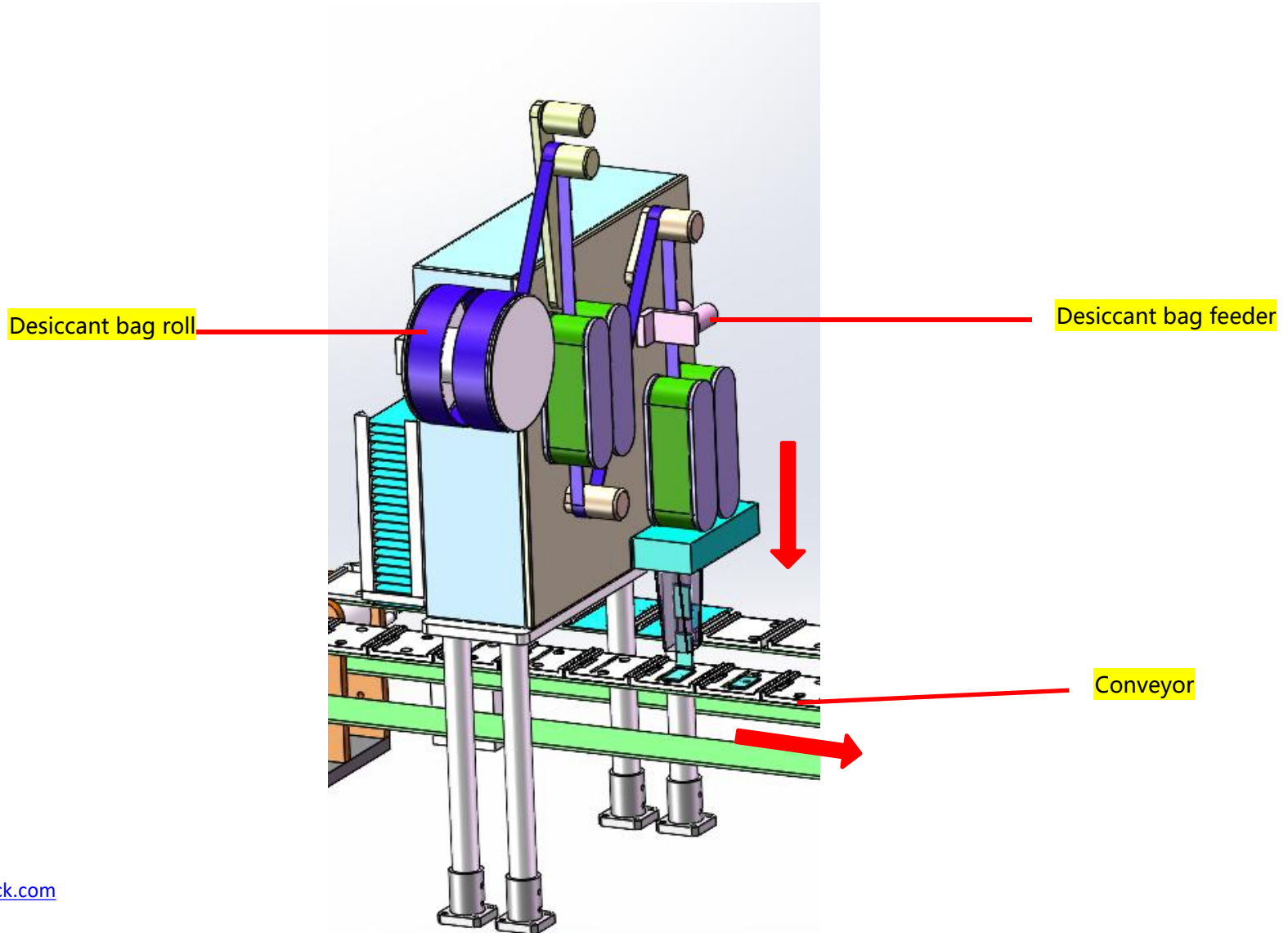



# Rapid Test Strip Packaging Machine

Test strip + desiccant + normal foil bag

## Desiccant insert into foil bag

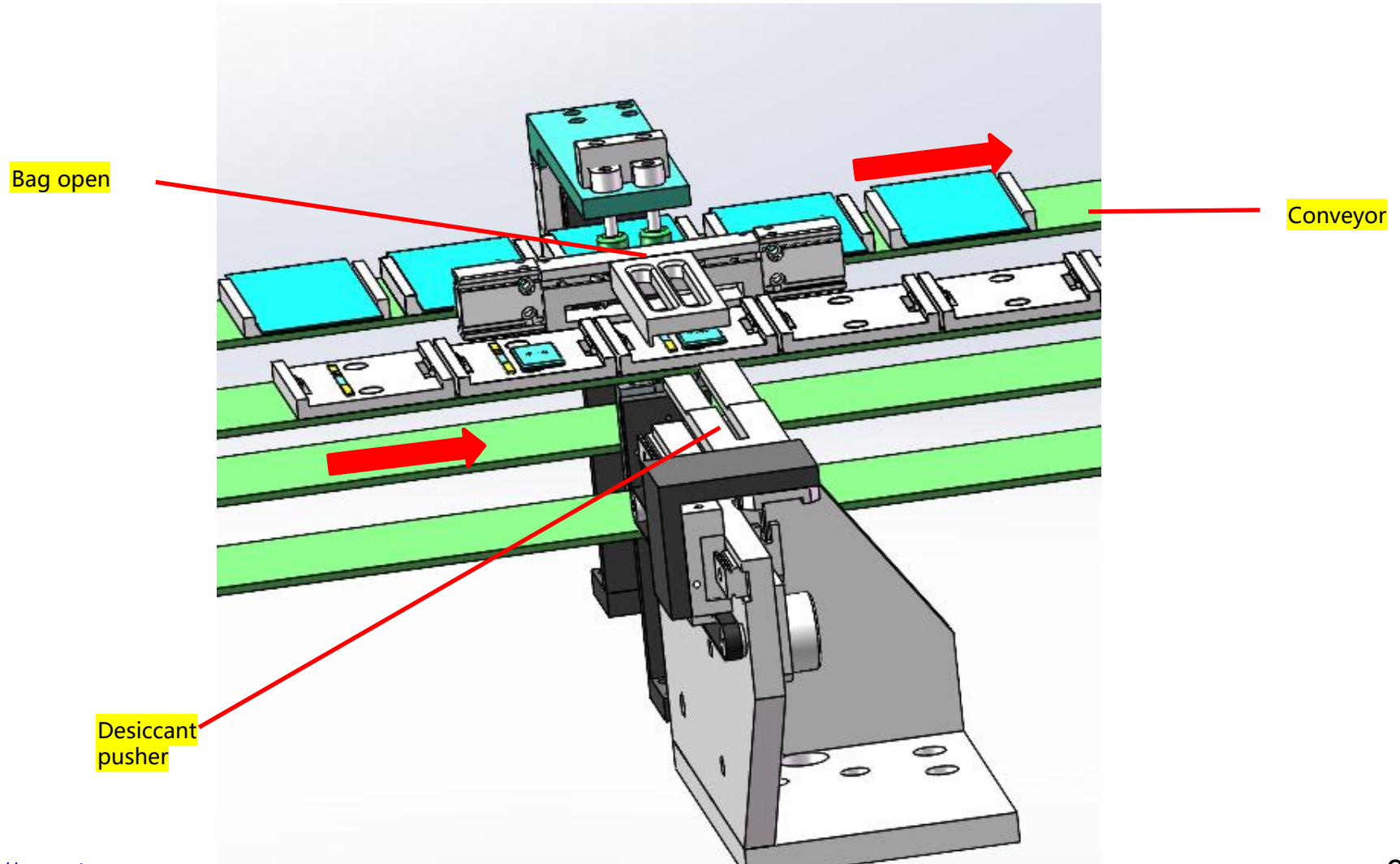



# Rapid Test Strip Packaging Machine

Test strip + desiccant + normal foil bag

## Foil bag sealing

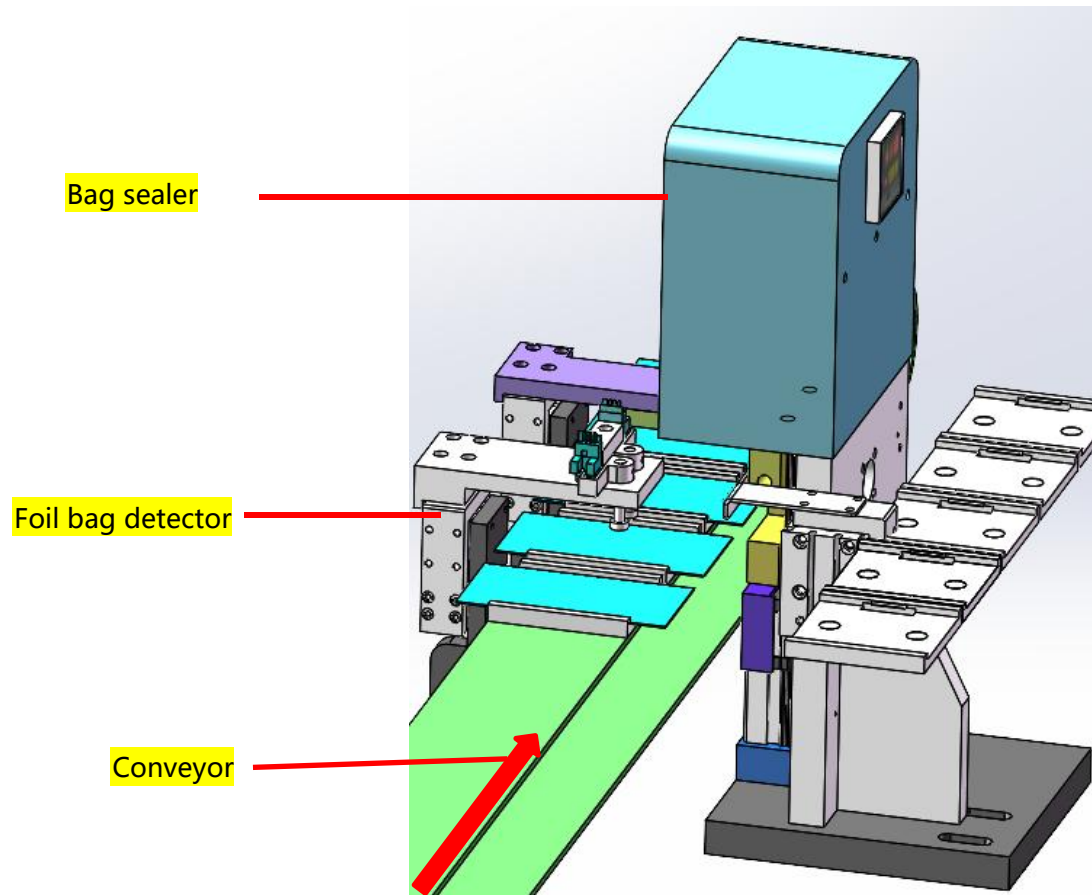

# Rapid Test Strip Packaging Machine

Test strip + desiccant + normal foil bag

## Output

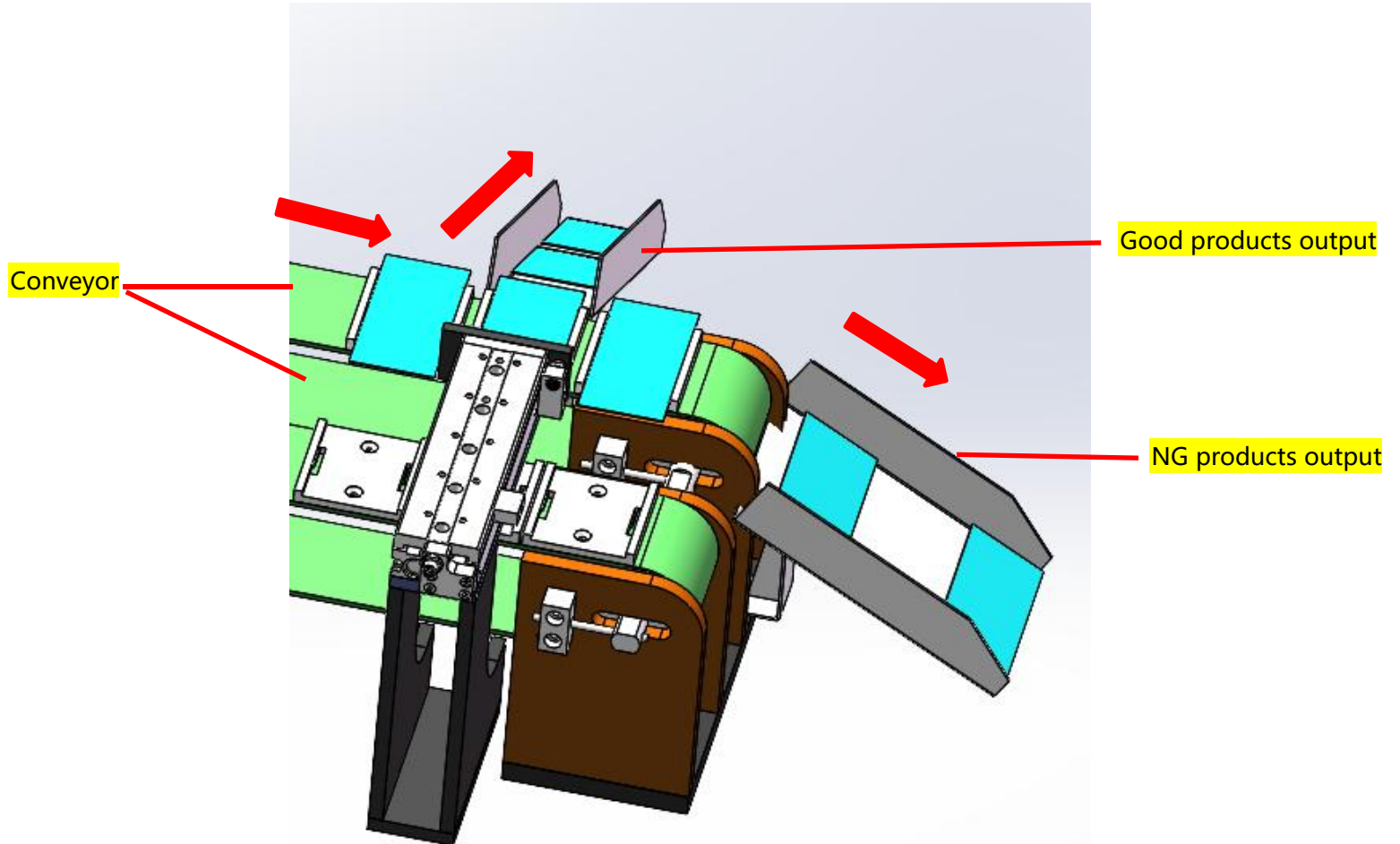

# Rapid Test Strip Packaging Machine

Test strip + desiccant + normal foil bag

## Features

1. English menu
2. Capacity: 1,500bags/hour
3. Easy for run and maintenance

## Operation

1. Connect with power supply and air supply
2. Manual insert foil bag
3. Install desiccant bag roll
4. Start machine
5. Manual feed strips
6. Keep running

## Rapid Test Strip Packaging Machine

Test strip + desiccant + normal foil bag

Parameters	
Capacity	1,500pcs/Hour
Activation	90%
Air supply	0.5~0.8MPa
Power supply	AC220V/50Hz
Internal power	DC/24V
Power	13.0 KW
Weight	800kg
Dimension	L1.3 * W0.8 * H1.85m
Wooden packing	---

## Rapid Test Strip Packaging Machine

Test strip + desiccant + normal foil bag

Key components	
PLC	Mitsubishi/Panasonic/other
Operation system	ANTITECK
Servo	Inovance/KNK
Relay	Schneider/CHNT
Sensor	OMRON/Panasonic
Cylinder	SMC/AIRTAC
Solenoid valve	SMC/AIRTAC
Connector	SMC/AIRTAC

# What ANTITECK can do?

**For automation product line**

non-standard automatic machine

## **Communication**

1. Customer provide details
2. Provide samples for machine design

## **Design**

Start designing

## **Equipments manufacturing**

In manufacturing process

## **Installation Commissioning**

Deliver machine  
Installation  
Commissioning