

Rapid Test Strip Packaging Machine

Strip Packaging Only

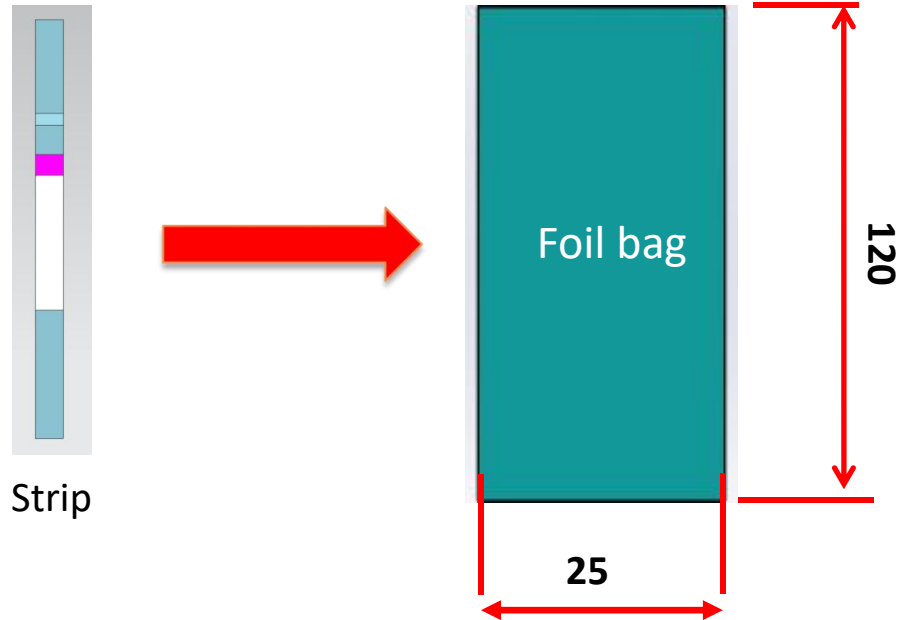

Workflow:

1. Automatic feeding foil bag
2. Manual feeding strips
3. Automatic open foil bag
4. Automatic insert strips into foil bag
5. Automatic seal foil bag
6. Finish

Rapid Test Strip Packaging Machine

Strip Packaging Only

Overview

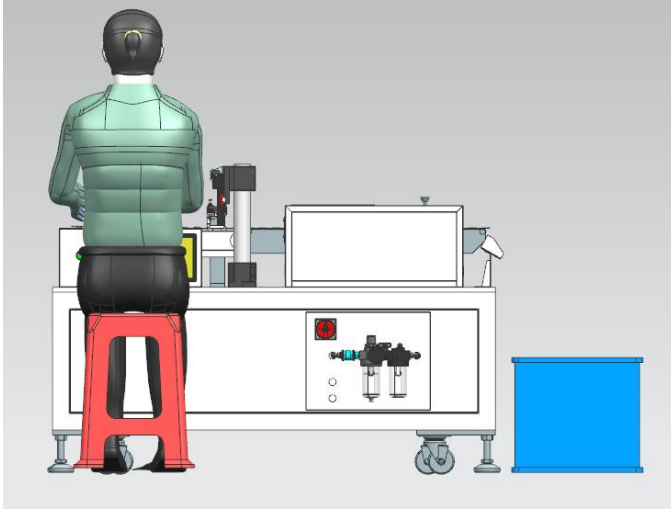

Front view

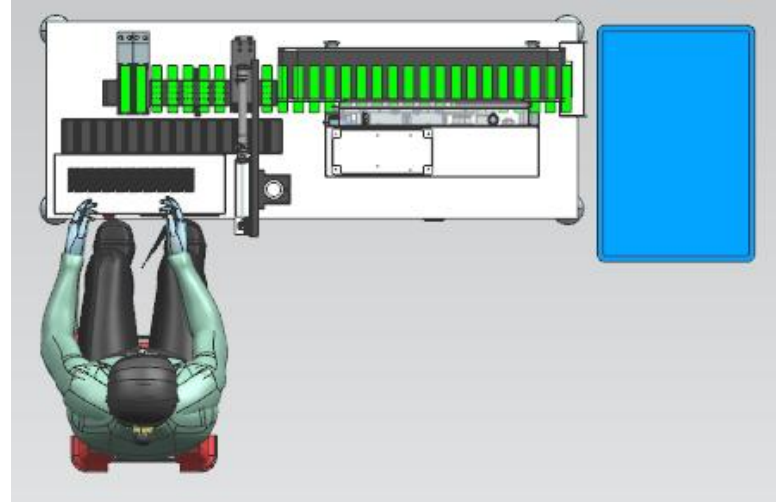

Top view

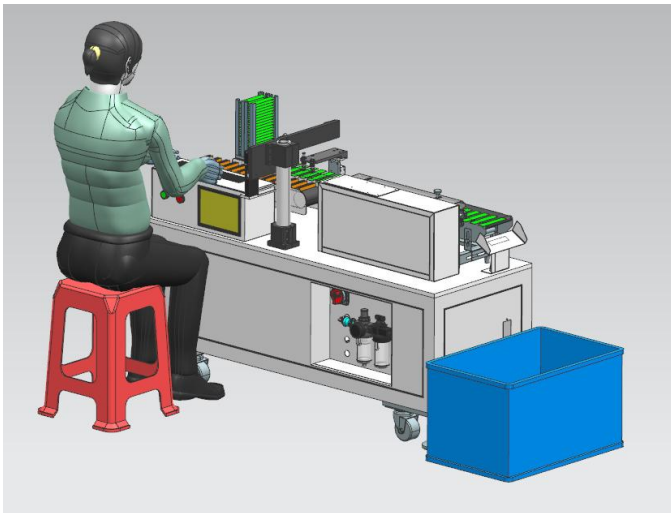

Side view

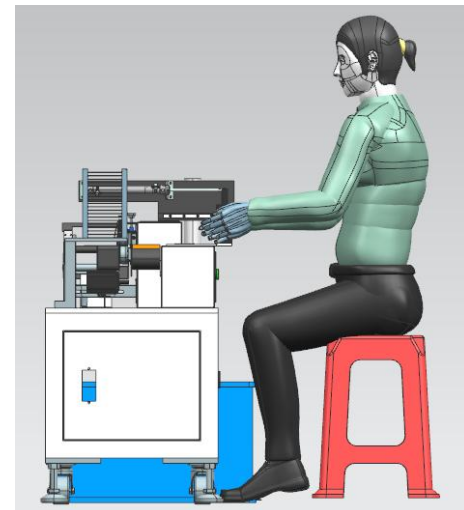

Right view

Rapid Test Strip Packaging Machine

Strip Packaging Only

Dimension

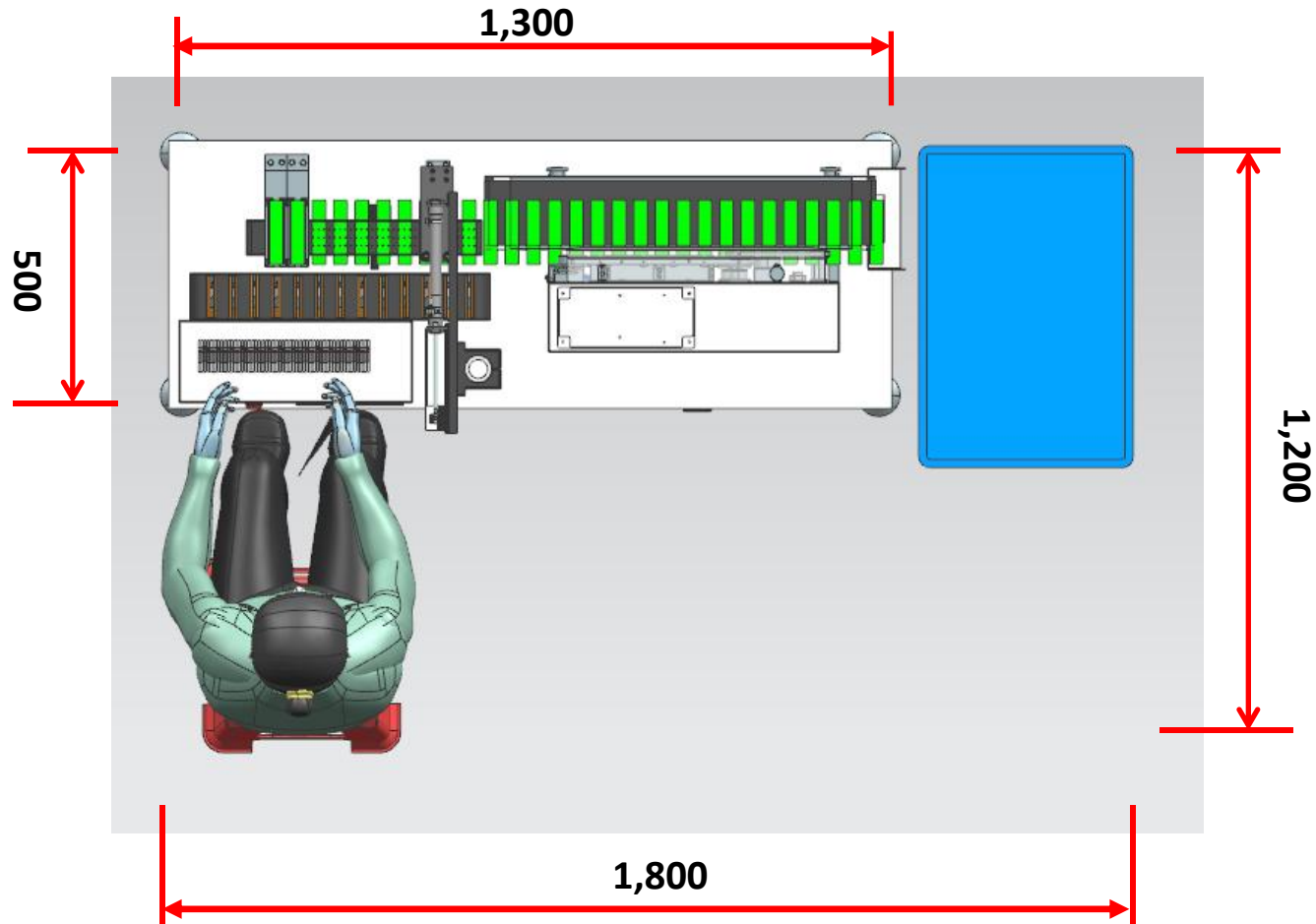

Dimension: 1,300mm x 500mm x 1,600(mm)

Rapid Test Strip Packaging Machine

Strip Packaging Only

Workstation

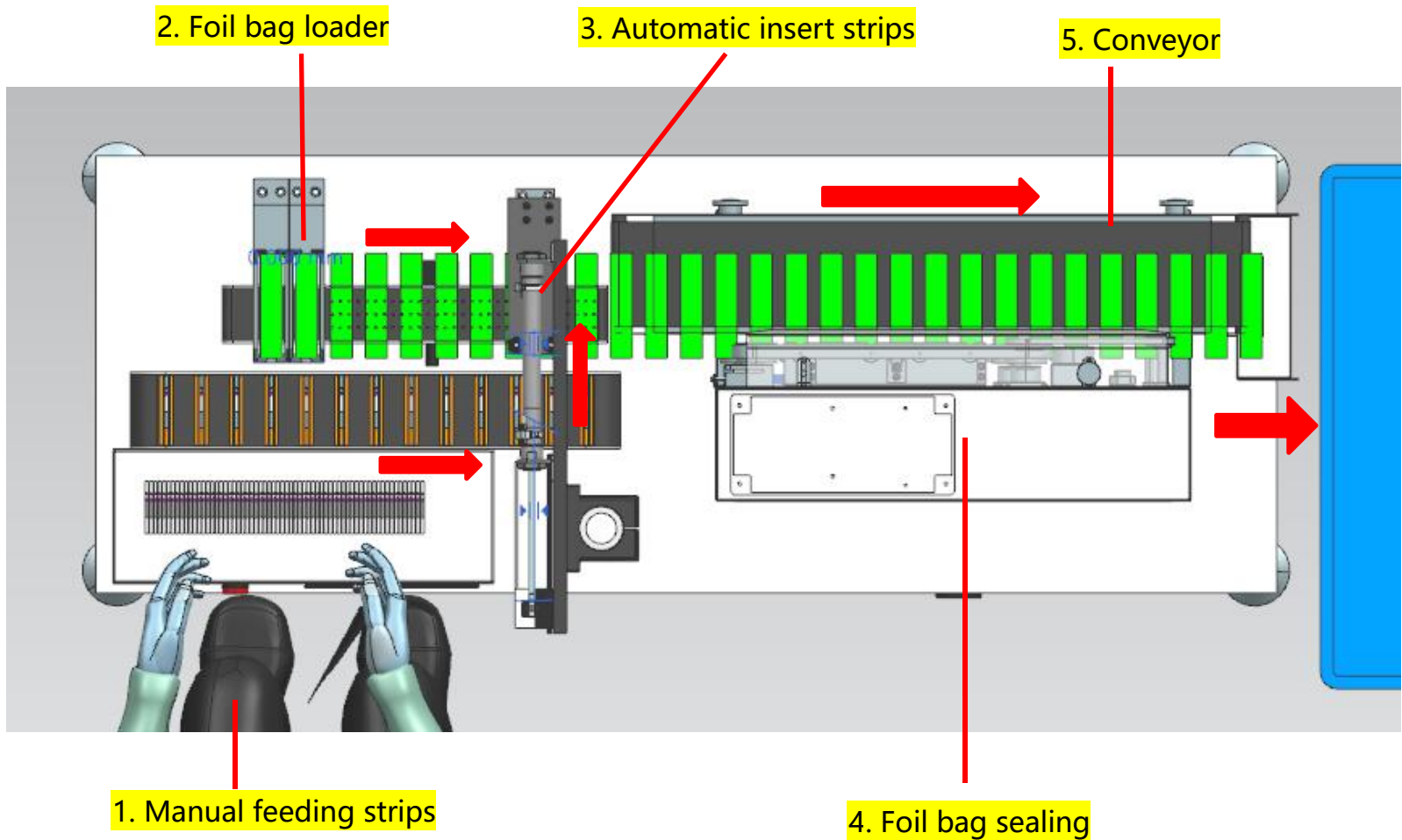

Rapid Test Strip Packaging Machine

Strip Packaging Only

Manual feeding strips

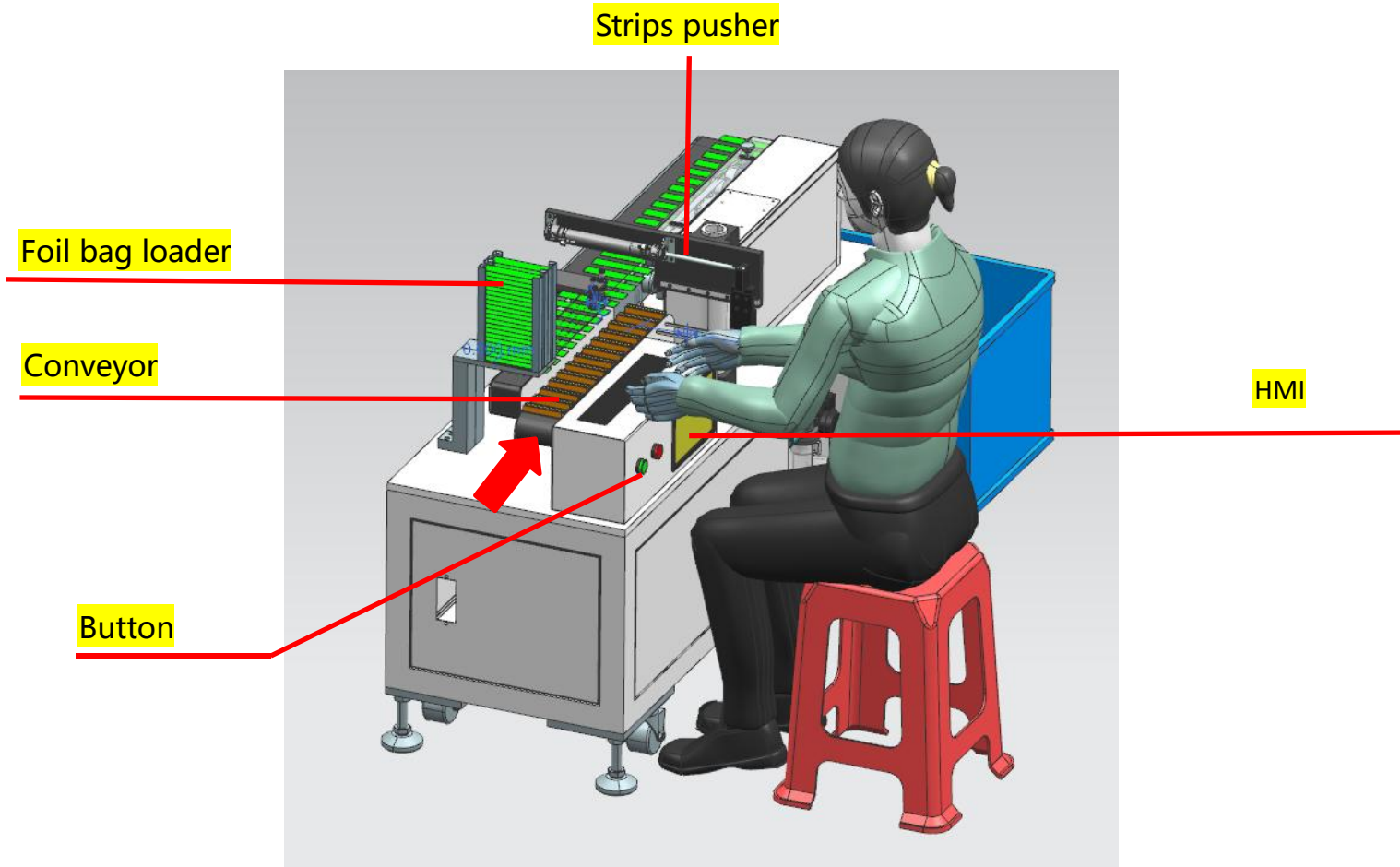

Rapid Test Strip Packaging Machine

Strip Packaging Only

Foil bag feeding

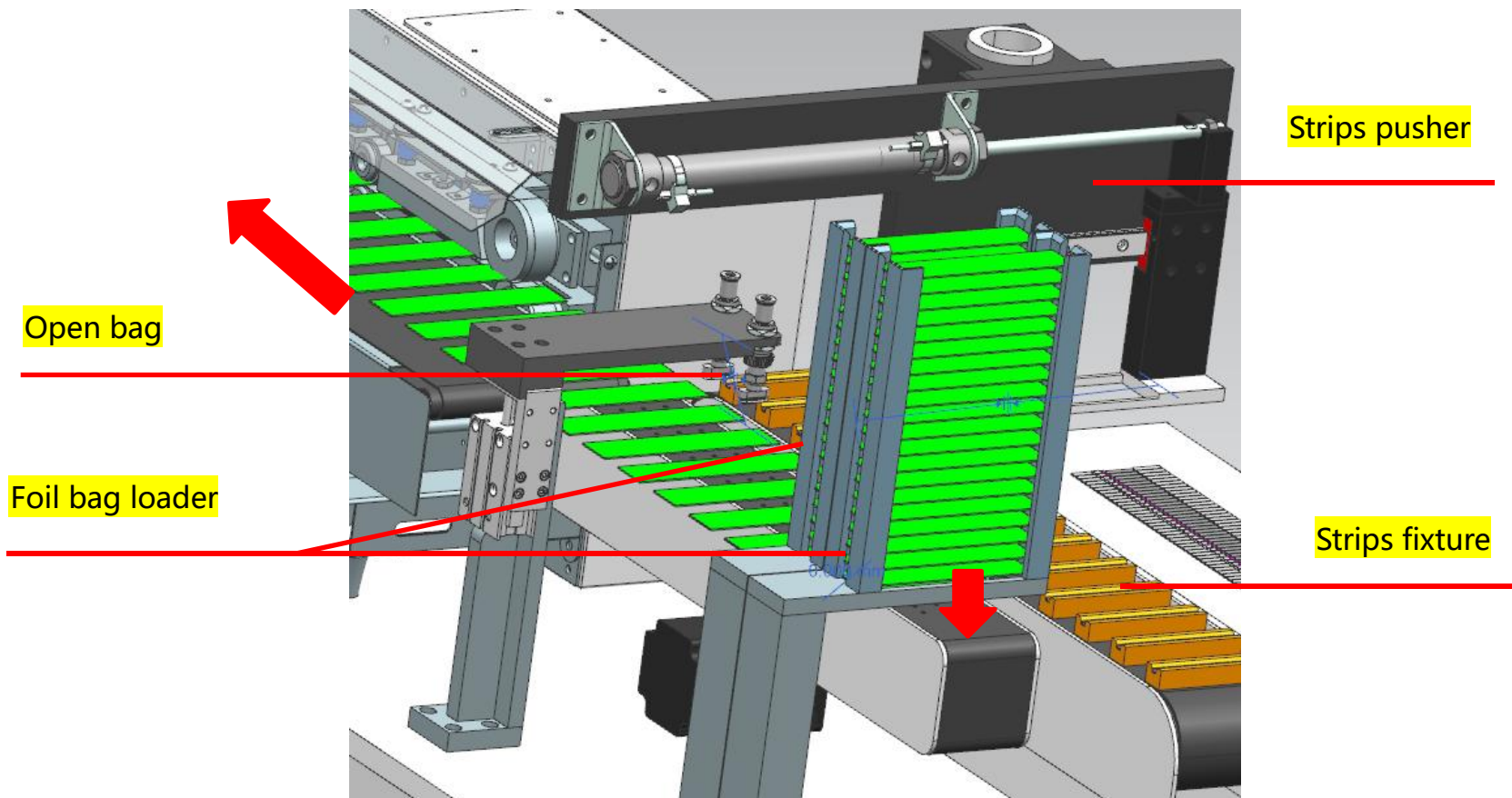

Rapid Test Strip Packaging Machine

Strip Packaging Only

Sealing bag

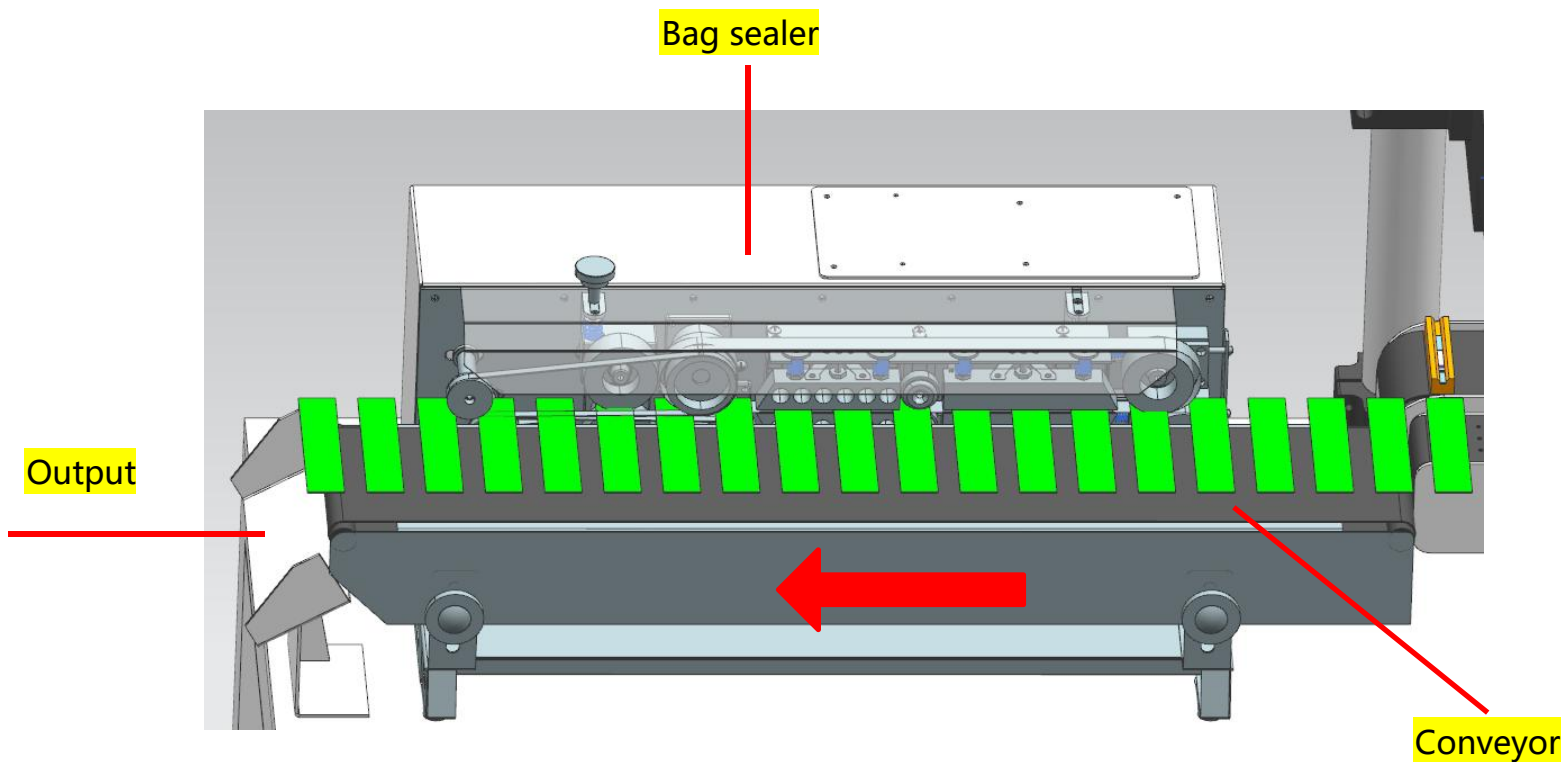

Rapid Test Strip Packaging Machine

Strip Packaging Only

About foil bag

It is made of desiccant film that already contain desiccant ingredient

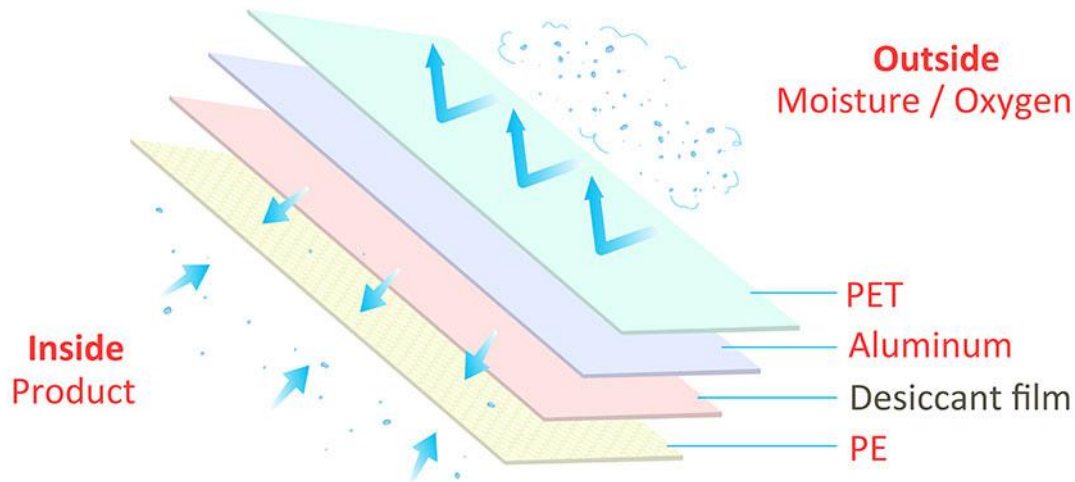

More details visit: <https://antiteck.com/desiccant-film/>

Features

1. English menu
2. Capacity: 2,000 bags/hour
3. Easy for run and maintenance

Operation

1. Connect with power supply and air supply
2. Insert foil bags into loader
3. Start machine
4. Manual feeding strips
5. Keep continue running

Rapid Test Strip Packaging Machine

Parameters	
Capacity	2,000pcs/Hour
Activation	90%
Air supply	0.5~0.8MPa
Power supply	AC220V/50Hz
Internal power	DC/24V
Power	13.0 KW
Weight	800kg
Dimension	L1.3 * W0.5 * H1.6m
Wooden packing	---

Rapid Test Strip Packaging Machine

Key components	
PLC	Mitsubishi/Panasonic/other
Operation system	ANTITECK
Servo	Inovance/KNK
Relay	Schneider/CHNT
Sensor	OMRON/Panasonic
Cylinder	SMC/AIRTAC
Solenoid valve	SMC/AIRTAC
Connector	SMC/AIRTAC

What ANTITECK can do?

For automation product line

non-standard automatic machine

Communication

1. Customer provide details
2. Provide samples for machine design

Design

Start designing

Equipments manufacturing

In manufacturing process

Installation Commissioning

Deliver machine
Installation
Commissioning