

Test Strip Assembly Machine

Single Strip / 5 Strips or 10 Strips Per Sheet, Semi Auto Assembly

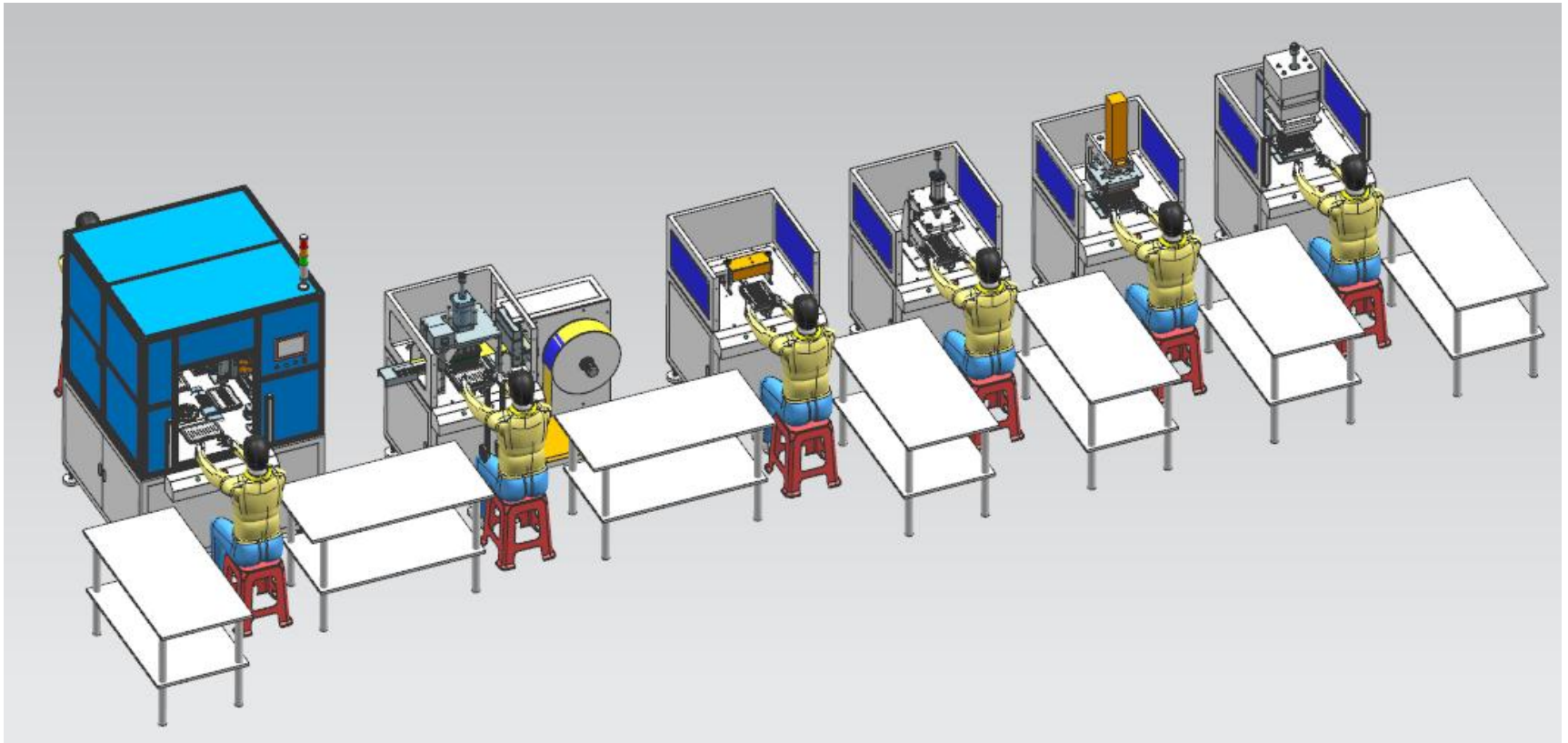

Test Strip Assembly Machine

Single Strip / 5 Strips or 10 Strips Per Sheet, Semi Auto Assembly

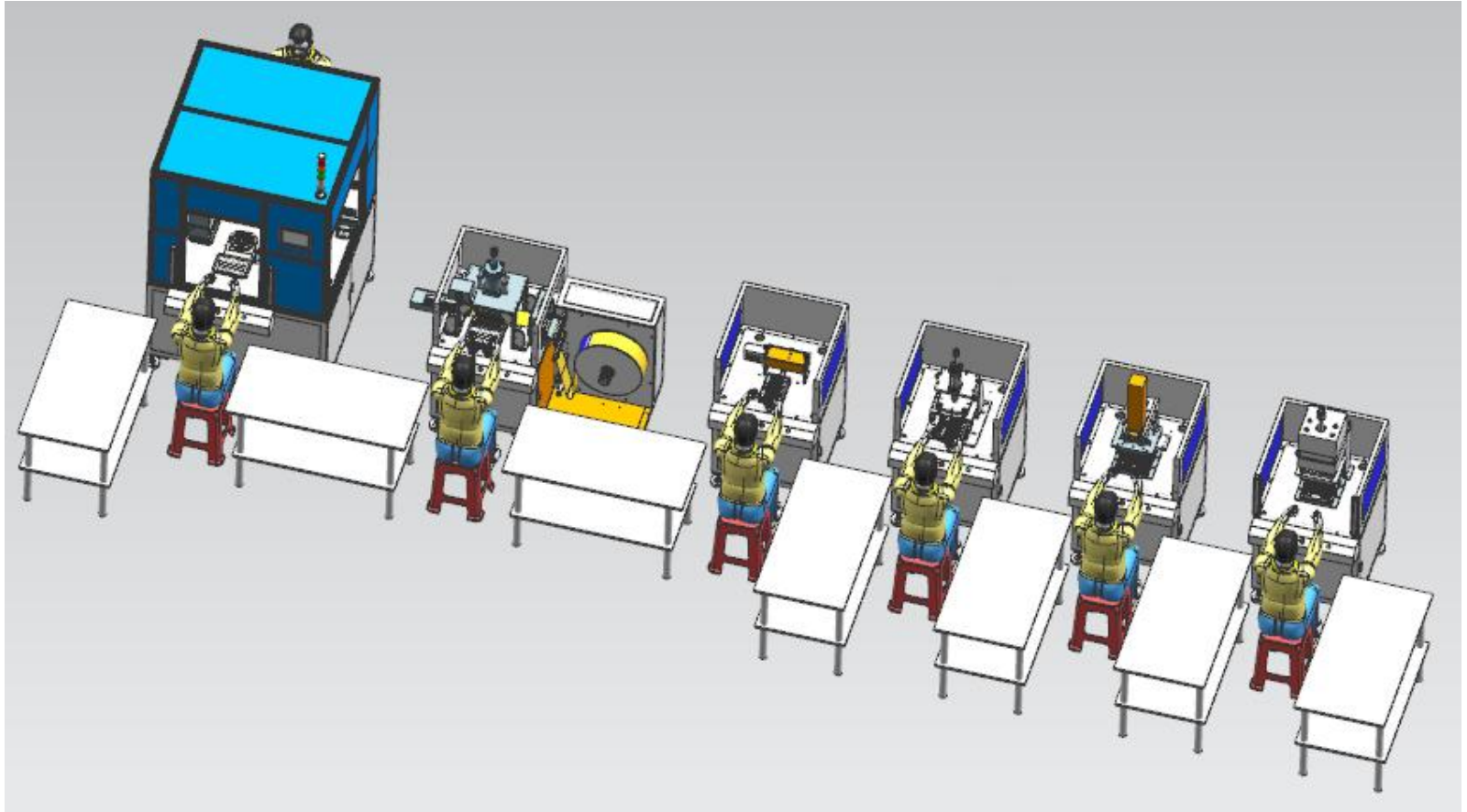

Test Strip Assembly Machine

Single Strip / 5 Strips or 10 Strips Per Sheet, Semi Auto Assembly

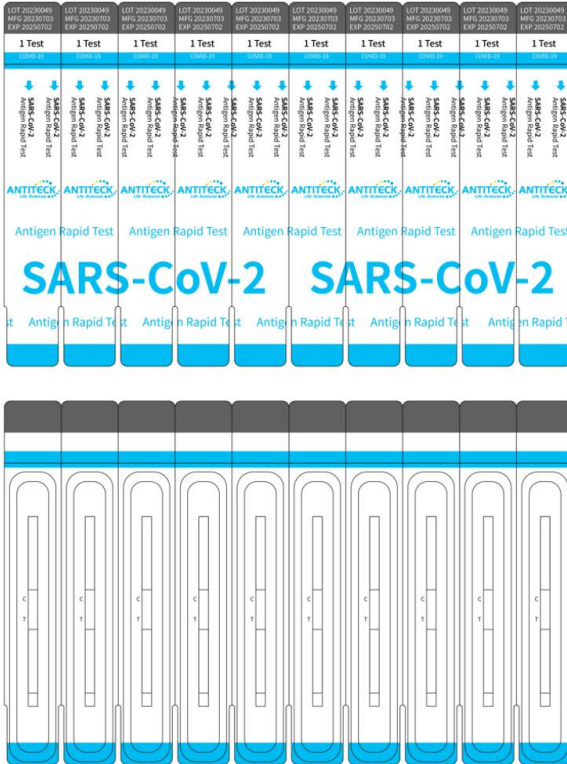

Requirement:

Test strip assembly machine: Semi Automated Processes:

1. Manual feed backing film
2. Manual feed the test strips on conveyor
3. Mechanical claw transfer strips on backing film
4. Press strip, let it stick stability
5. Cut the stop line (Option)
6. Cut easy tear line
7. Cut the R rounded corners
8. Final cut and finish

Test Strip Assembly Machine

Single Strip / 5 Strips or 10 Strips Per Sheet, Semi Auto Assembly

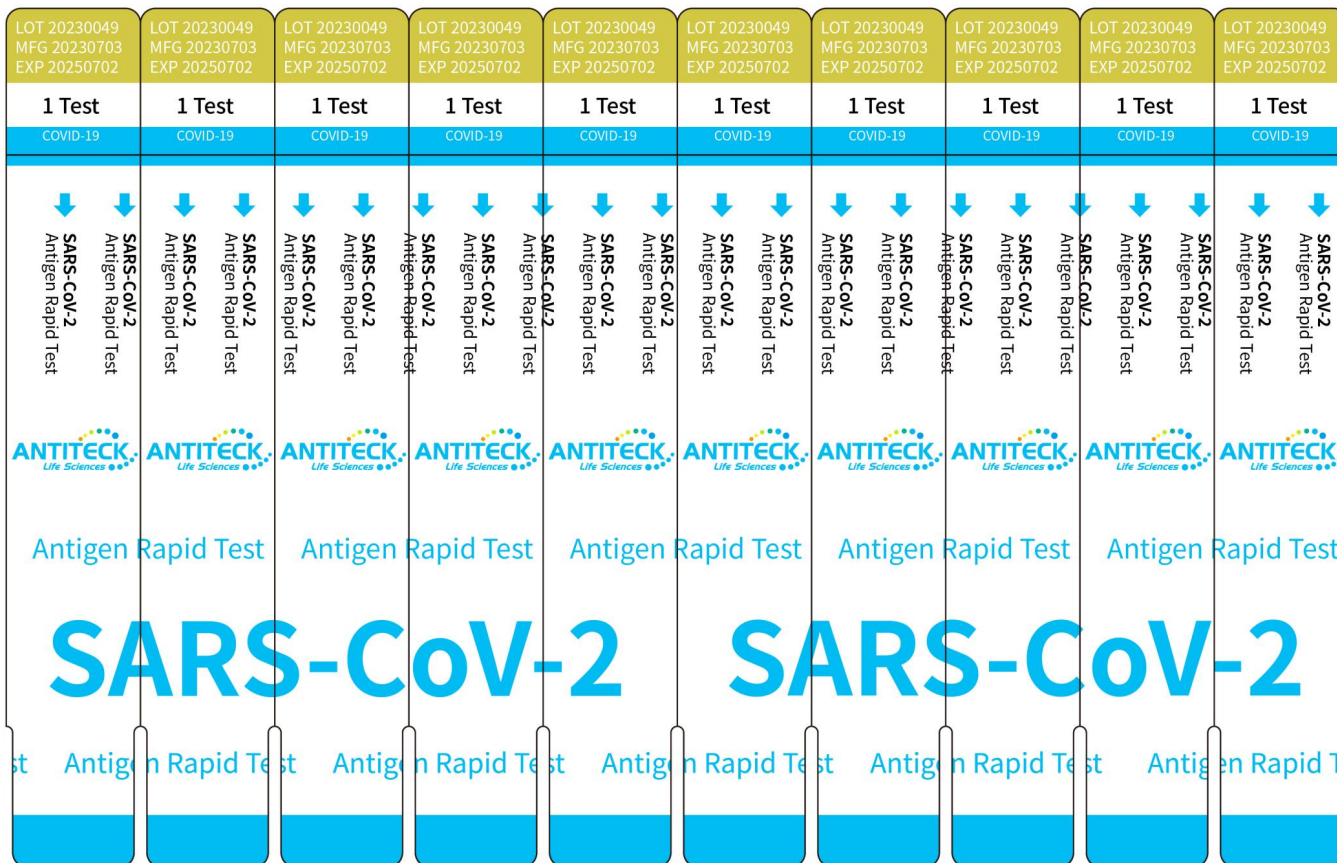

10 tests per sheet, film cover

Test Strip Assembly Machine

Single Strip / 5 Strips or 10 Strips Per Sheet, Semi Auto Assembly

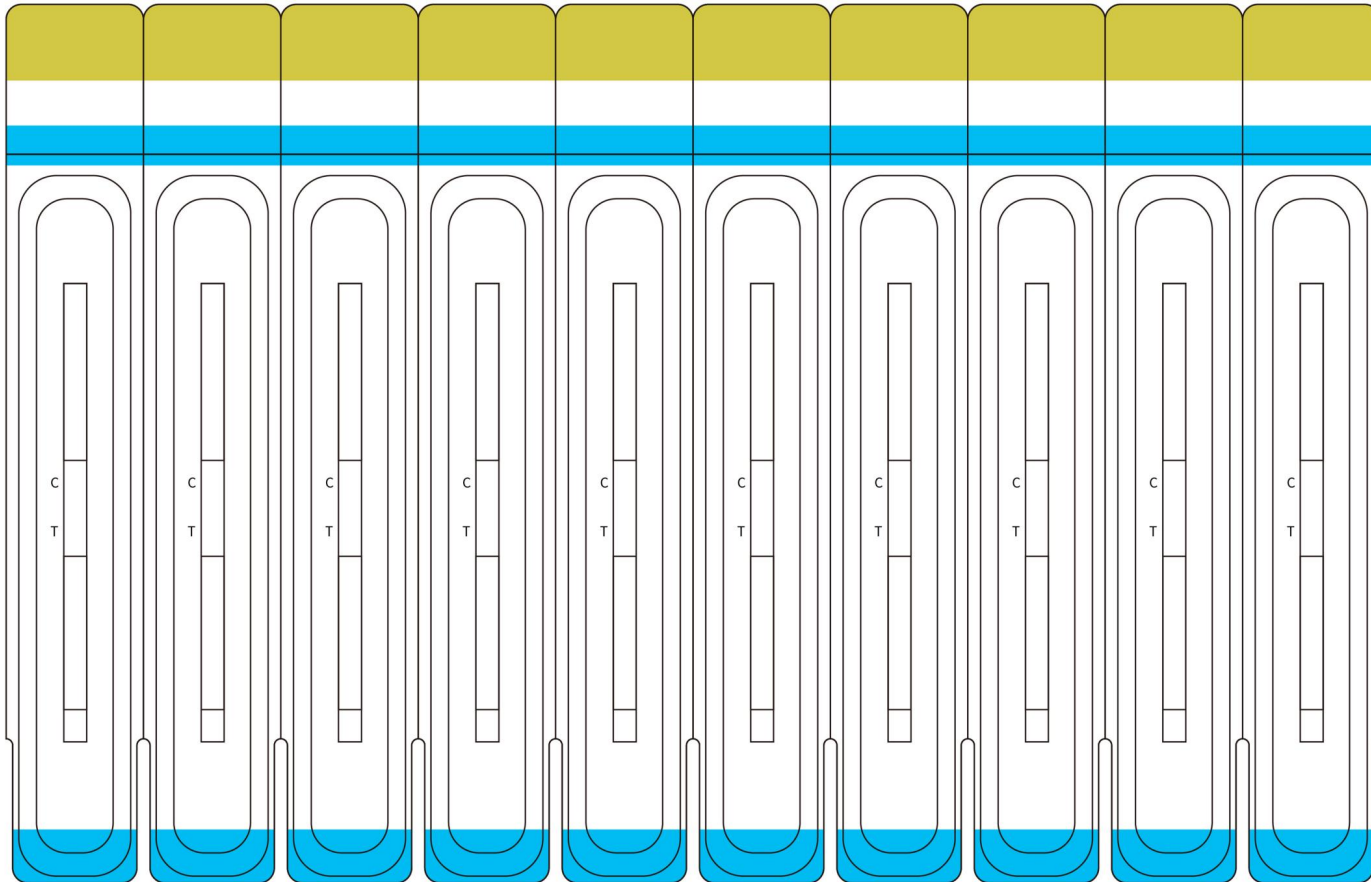

Film backing

Test Strip Assembly Machine

Single Strip / 5 Strips or 10 Strips Per Sheet, Semi Auto Assembly

Workshop space requirement

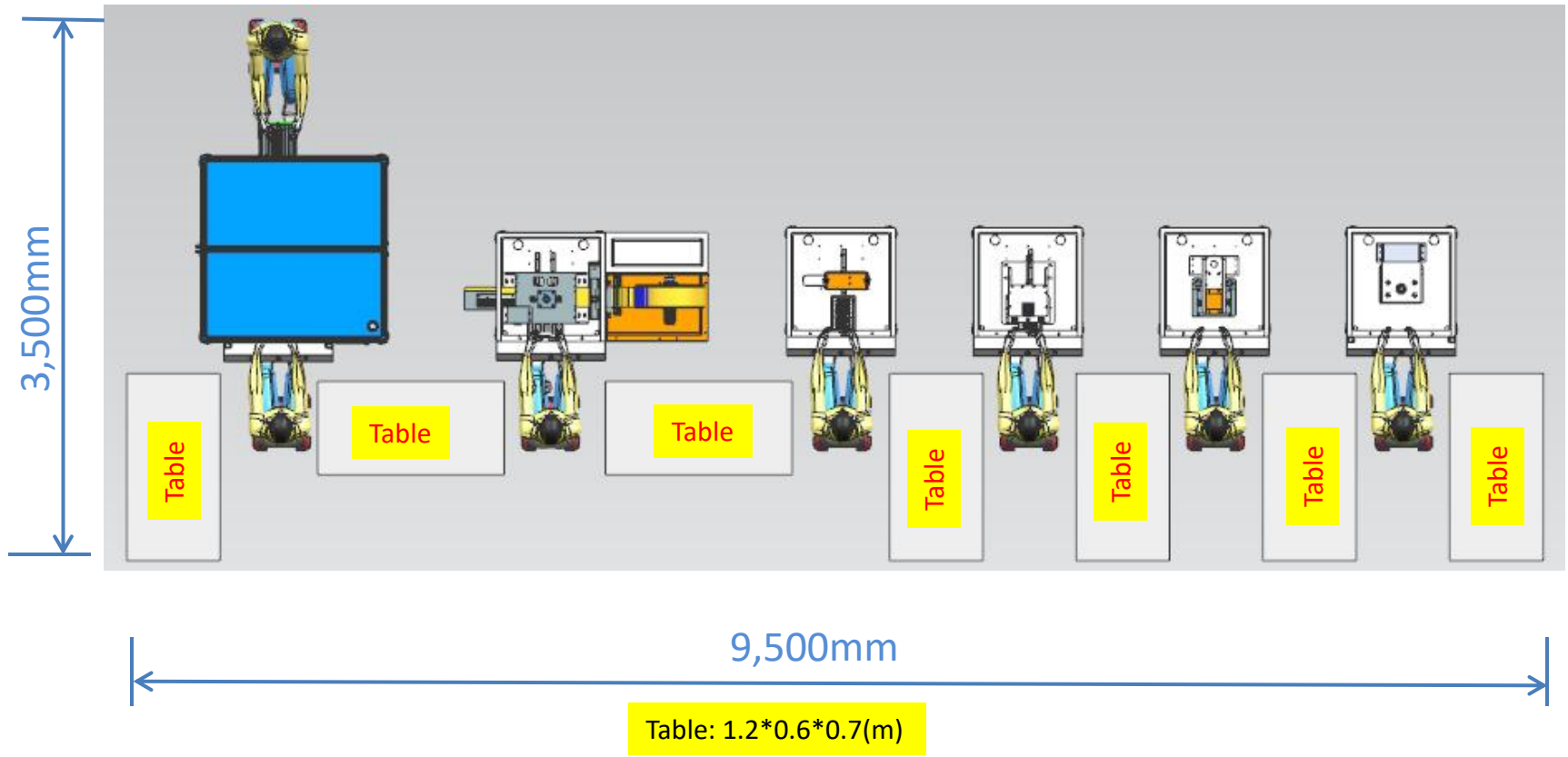

Test Strip Assembly Machine

Single Strip / 5 Strips or 10 Strips Per Sheet, Semi Auto Assembly

Workflow

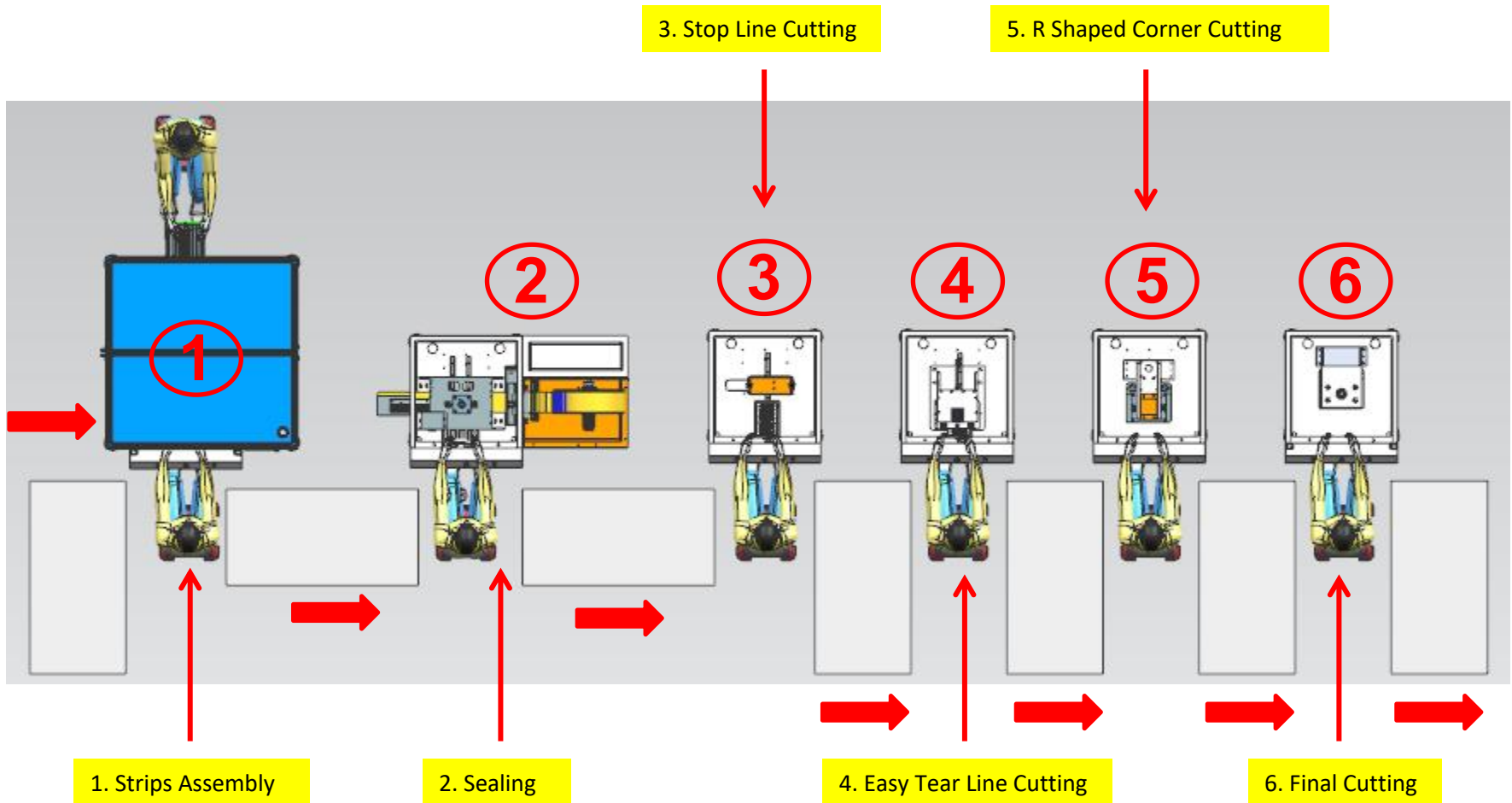

Test Strip Assembly Machine

Single Strip / 5 Strips or 10 Strips Per Sheet, Semi Auto Assembly

Process Description

Strips preparation

Use individual strip cutter to cut the uncut sheet



Uncut sheet



Strip cutter



Strips

Test Strip Assembly Machine

Single Strip / 5 Strips or 10 Strips Per Sheet, Semi Auto Assembly

Process Description

1. Strips assembly

- a, manual feed the backing film
- b, manual feed the strips
- c, automated stick strips on backing film

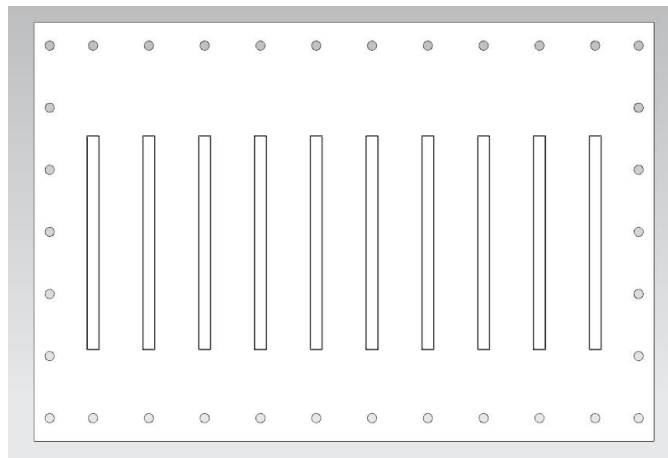

The backing film

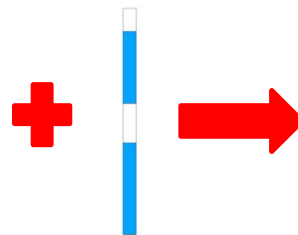

Strip

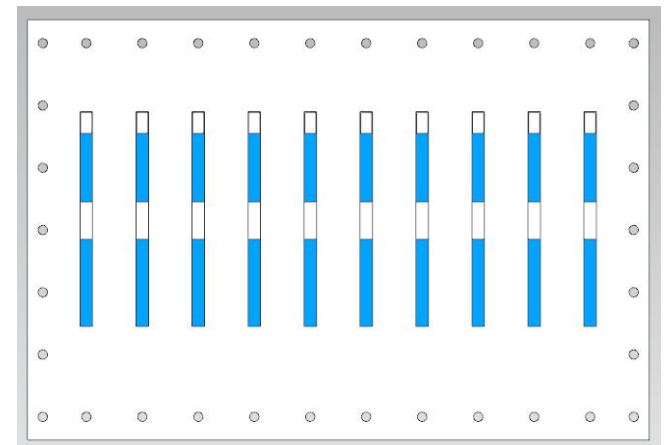

Strips stick on backing film

Test Strip Assembly Machine

Single Strip / 5 Strips or 10 Strips Per Sheet, Semi Auto Assembly

Process Description

2. Sealing

a, manual feed the cover film

b, automated seal

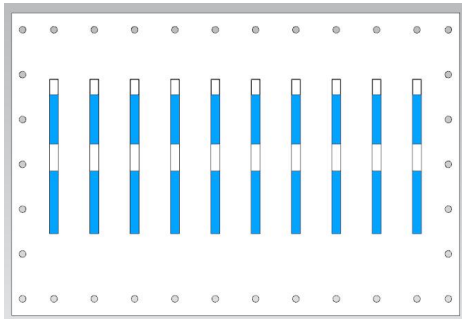

Strips with backing film

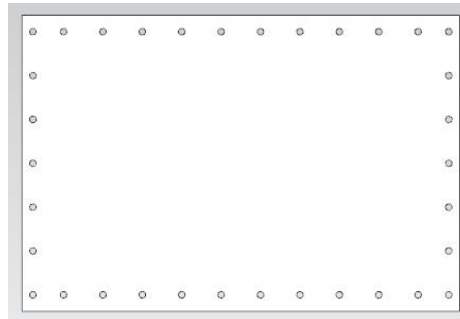

Cover film

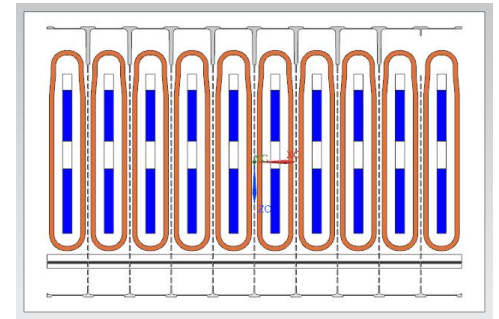

After sealed

Test Strip Assembly Machine

Single Strip / 5 Strips or 10 Strips Per Sheet, Semi Auto Assembly

Process Description

3. Stop Line Cutting (option)

a, manual feed the sheet

b, automate cutting the stop line

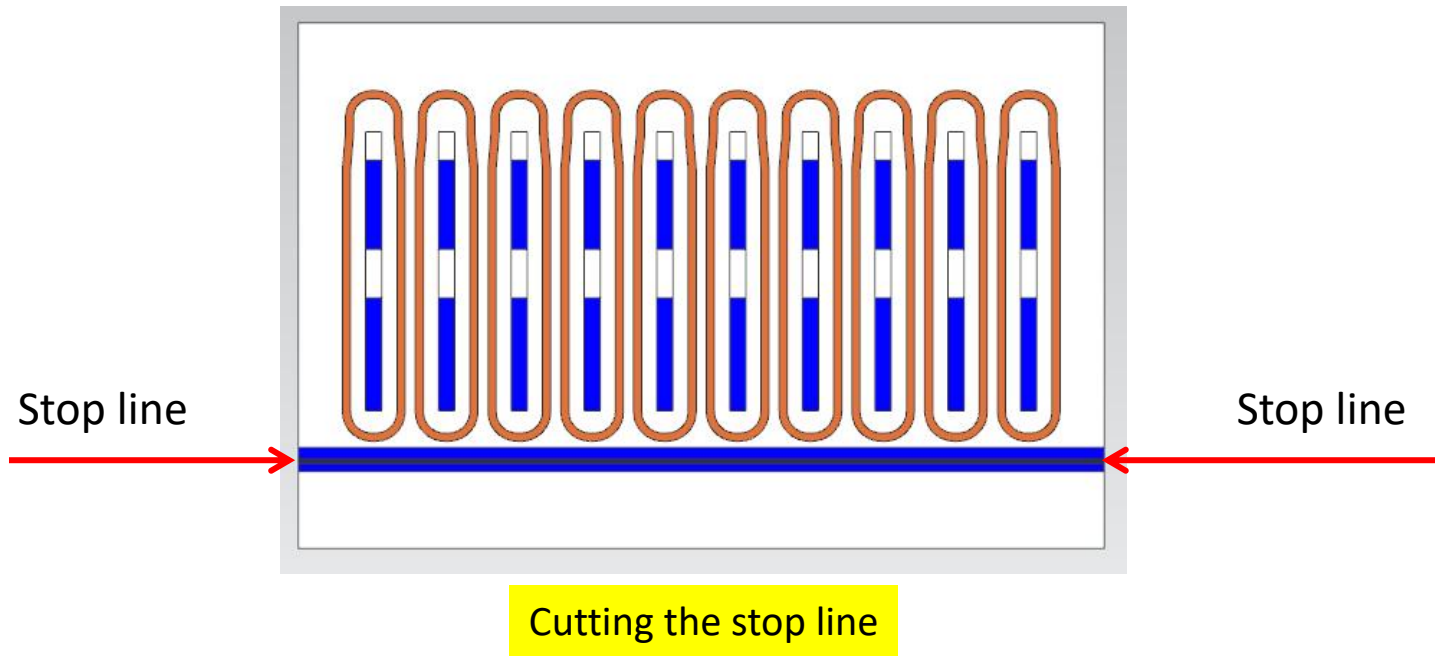

Test Strip Assembly Machine

Single Strip / 5 Strips or 10 Strips Per Sheet, Semi Auto Assembly

Process Description

4. Easy Tear Line Cutting

a, manual feed the sheet

b, automate cutting the easy tear line

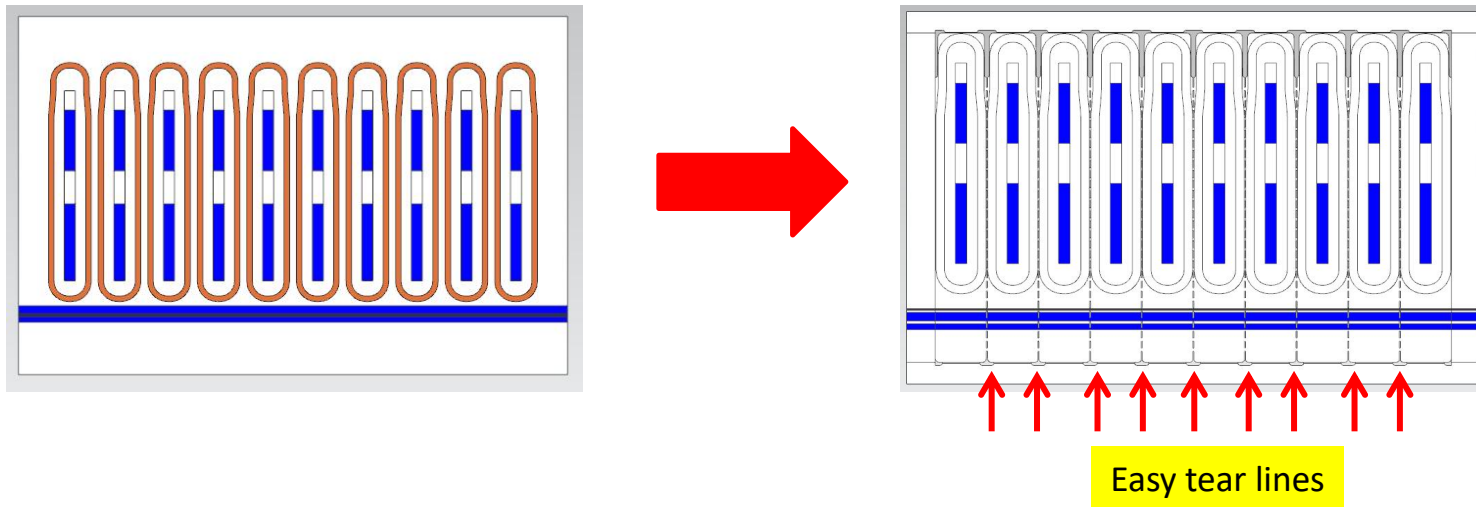

Test Strip Assembly Machine

Single Strip / 5 Strips or 10 Strips Per Sheet, Semi Auto Assembly

Process Description

5. R Shaped Corner Cutting

a, manual feed the sheet

b, automate cutting the R shaped corners

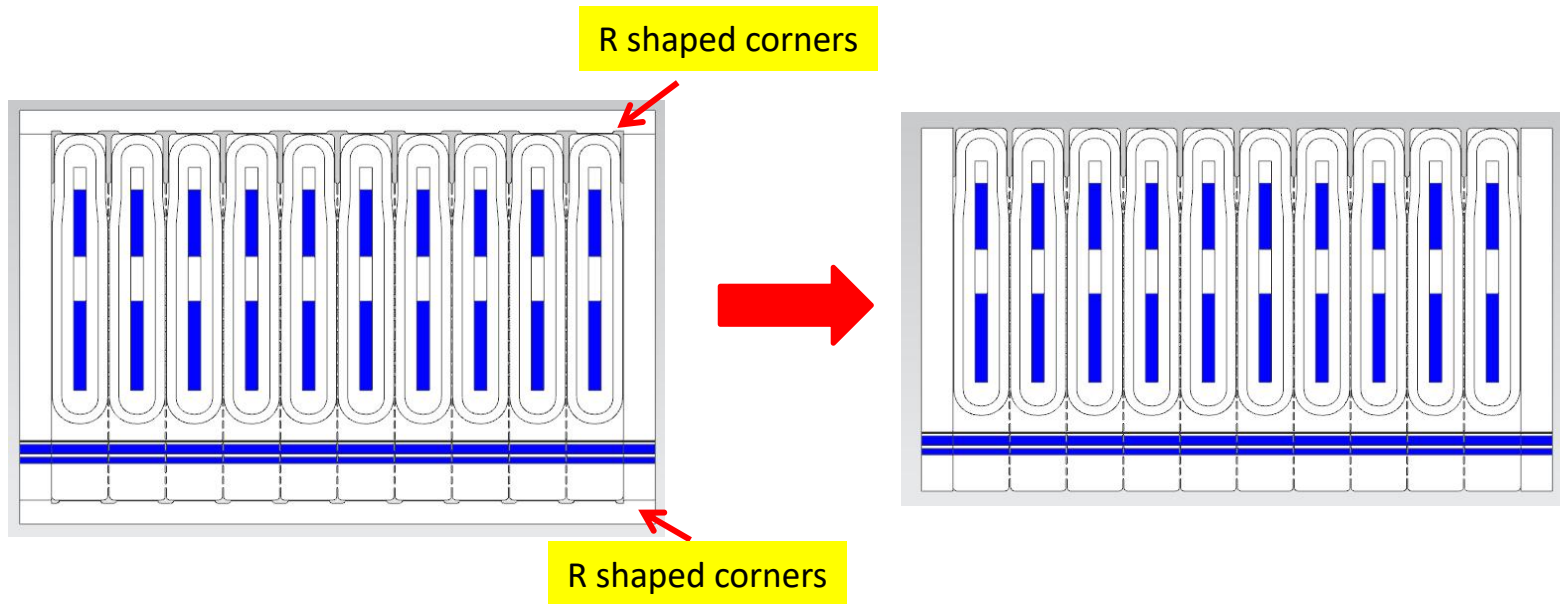

Test Strip Assembly Machine

Single Strip / 5 Strips or 10 Strips Per Sheet, Semi Auto Assembly

Process Description

6. Final Cutting

a, manual feed the sheet

b, automate cutting the side material

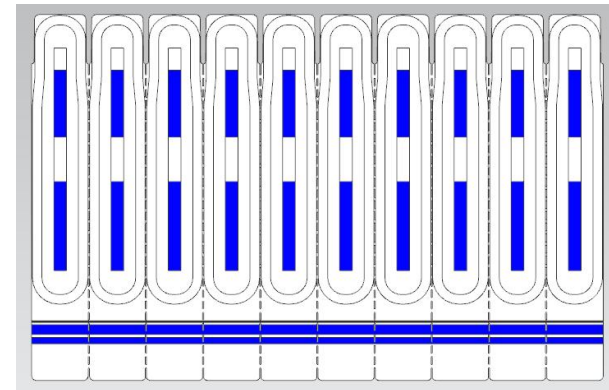
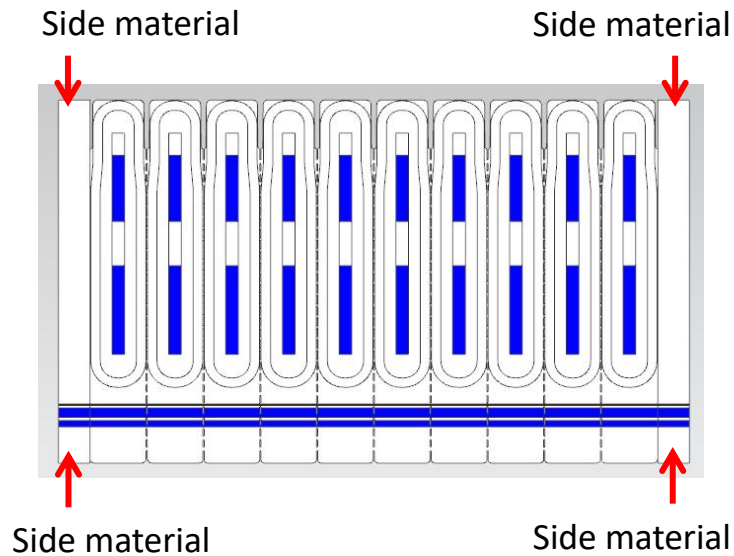

Final sheet - 10 Strips/sheet

Test Strip Assembly Machine

Single Strip / 5 Strips or 10 Strips Per Sheet, Semi Auto Assembly

Machines Overview

1. Strips Assembly Machine

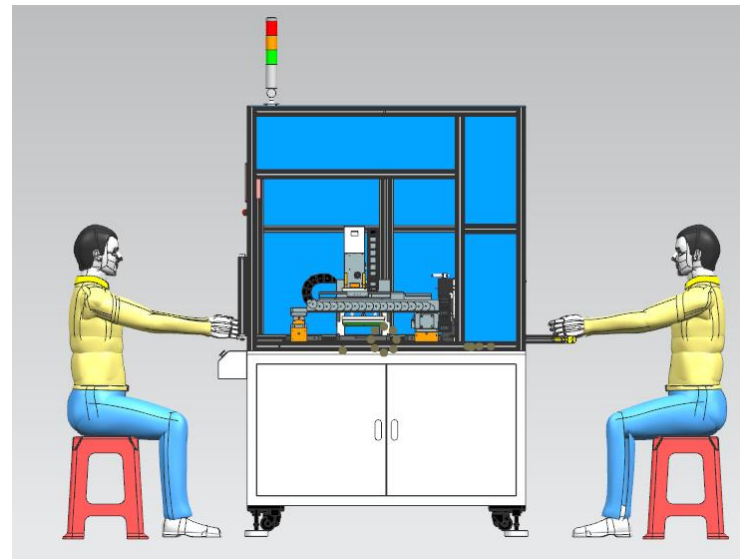
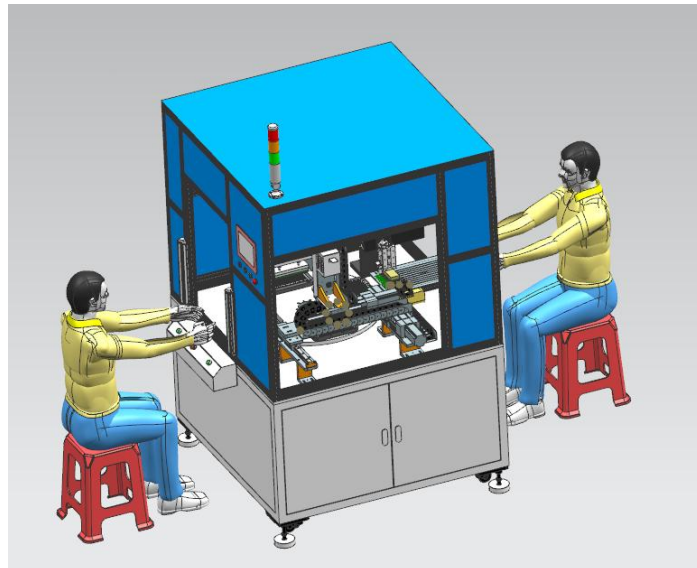
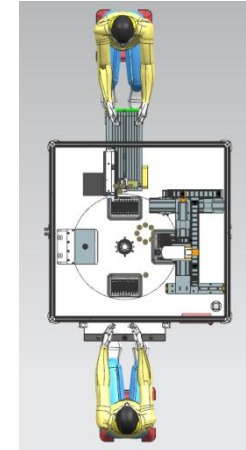

Test Strip Assembly Machine

Single Strip / 5 Strips or 10 Strips Per Sheet, Semi Auto Assembly

1. Strips assembly machine

- a, manual feed the backing film
- b, manual feed the strips
- c, automated stick strips on backing film

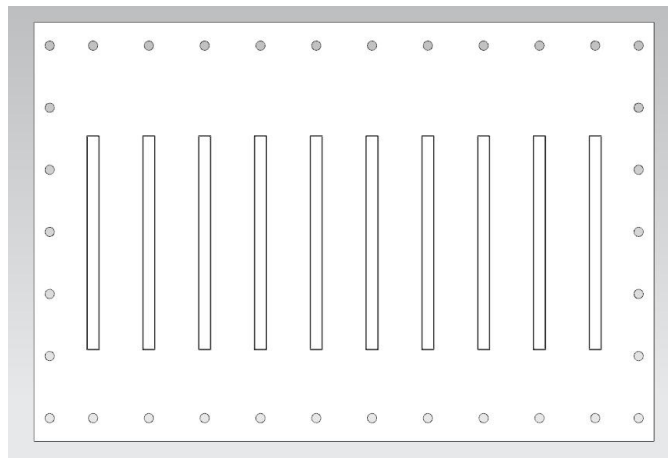

The backing film

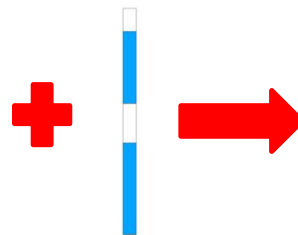

Strip

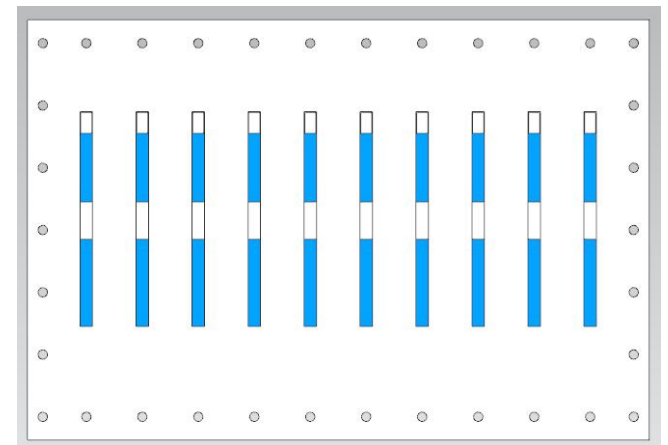

Strips stick on backing film

Test Strip Assembly Machine

Single Strip / 5 Strips or 10 Strips Per Sheet, Semi Auto Assembly

Machines Overview

1. Strips Assembly Machine Dimension

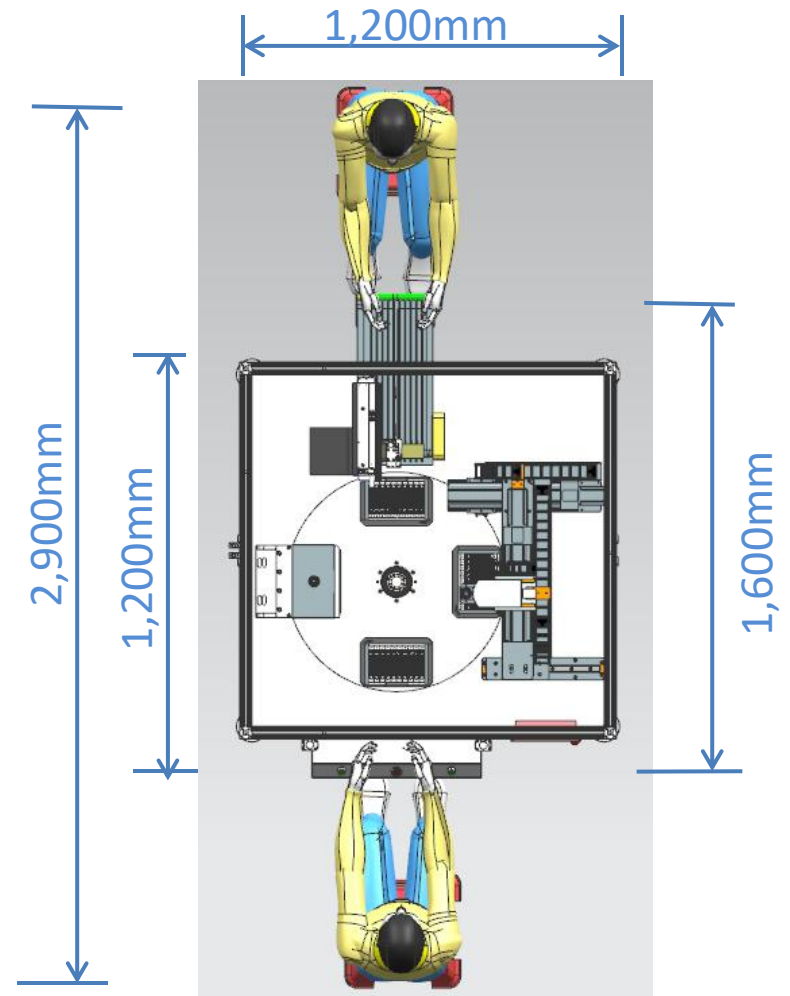
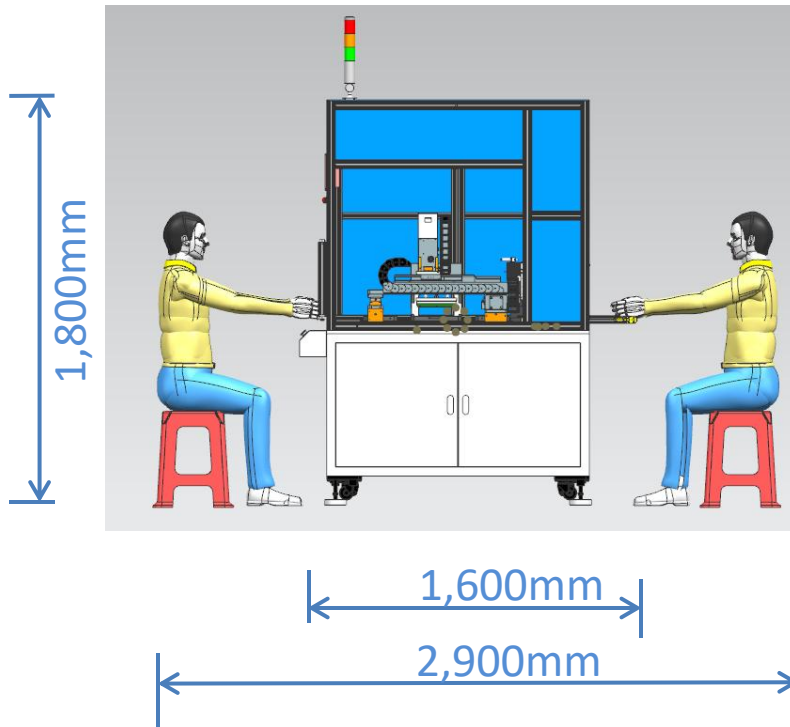

Test Strip Assembly Machine

Single Strip / 5 Strips or 10 Strips Per Sheet, Semi Auto Assembly

Machines Overview

1. Strips Assembly Machine Workstations

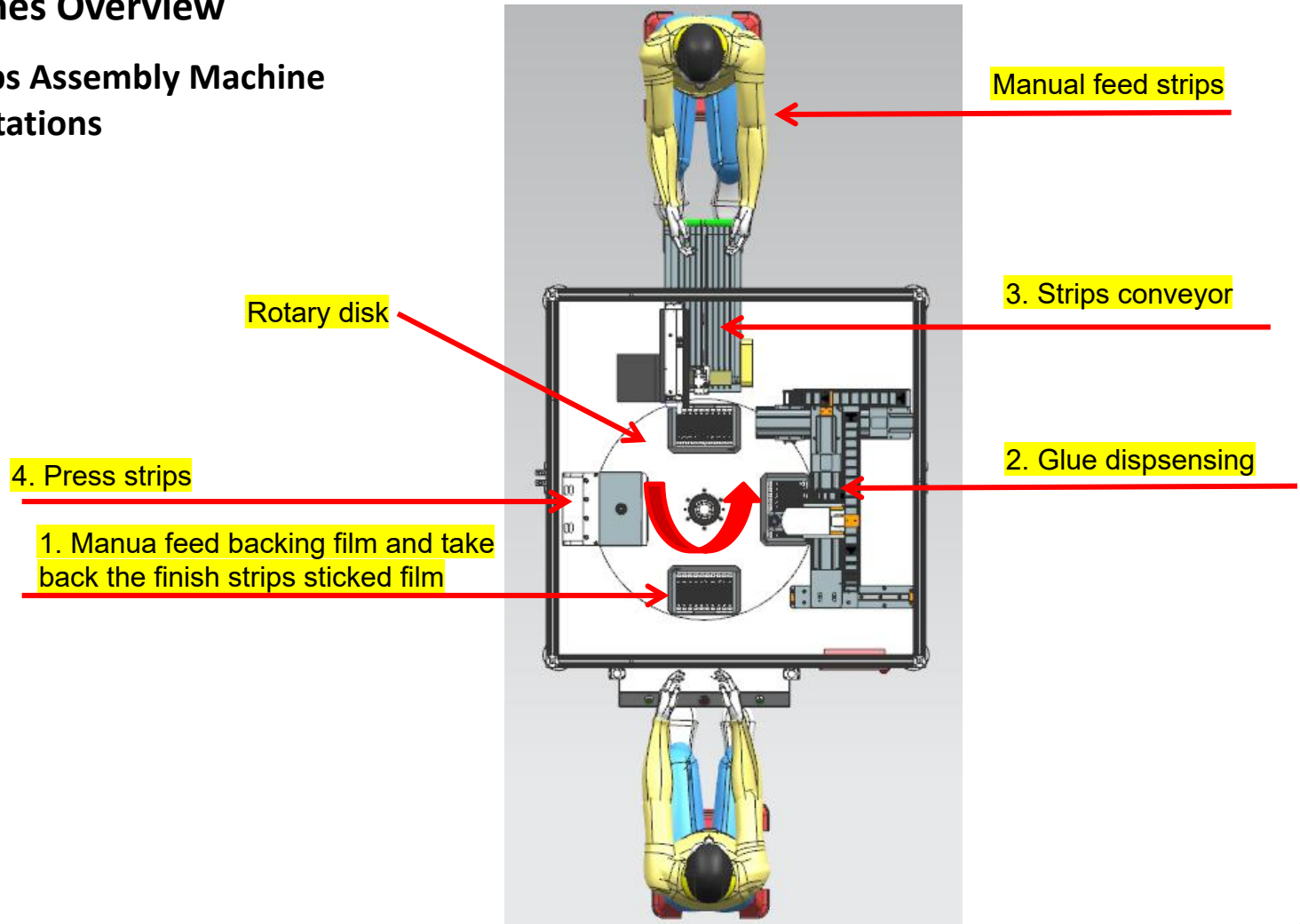

Test Strip Assembly Machine

Single Strip / 5 Strips or 10 Strips Per Sheet, Semi Auto Assembly

Machines Overview

1. Strips Assembly Machine

Workstation 1

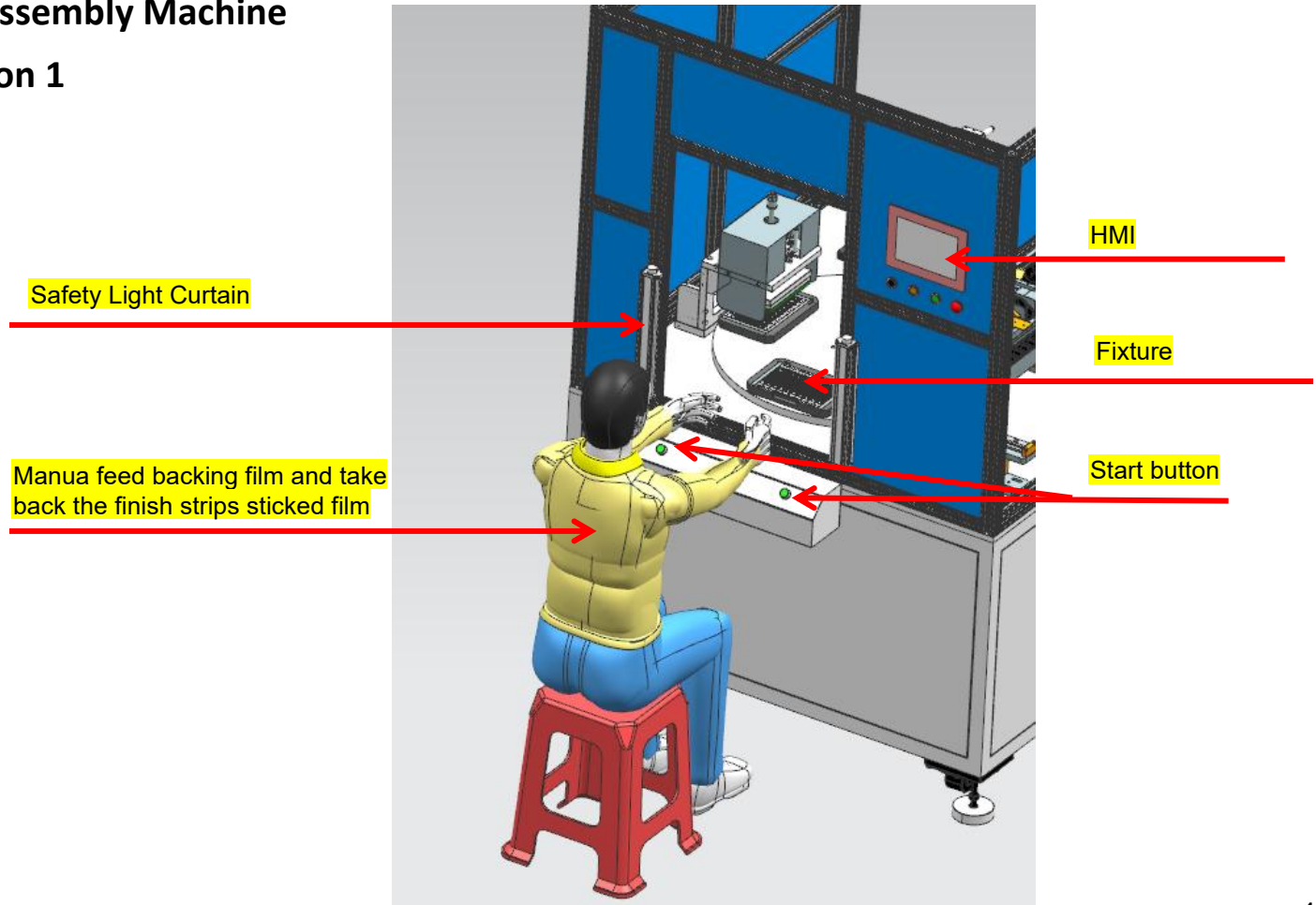

Test Strip Assembly Machine

Single Strip / 5 Strips or 10 Strips Per Sheet, Semi Auto Assembly

Machines Overview

1. Strips Assembly Machine

Workstation 2 - Glue dispensing

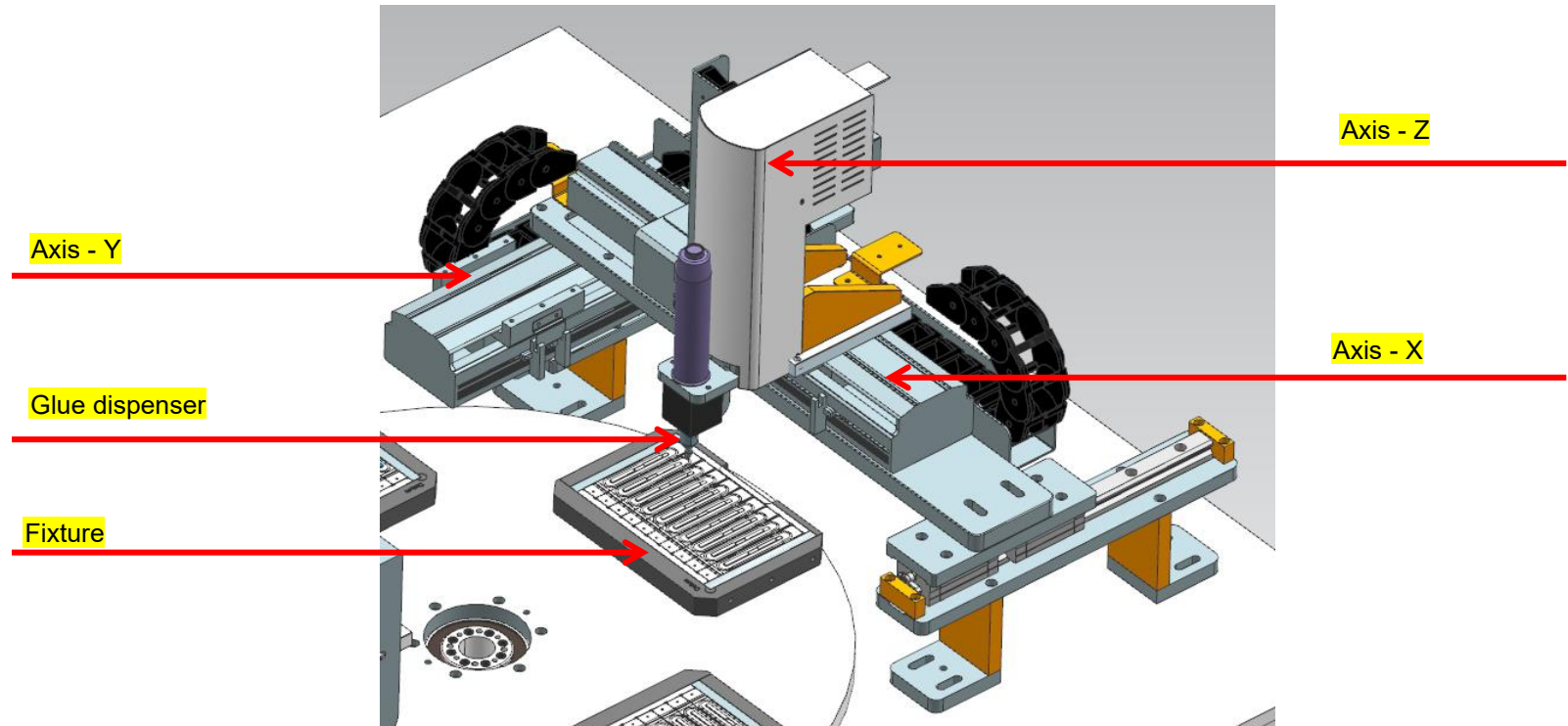

Test Strip Assembly Machine

Single Strip / 5 Strips or 10 Strips Per Sheet, Semi Auto Assembly

Machines Overview

1. Strips Assembly Machine

Workstation 3 - Strips feeding

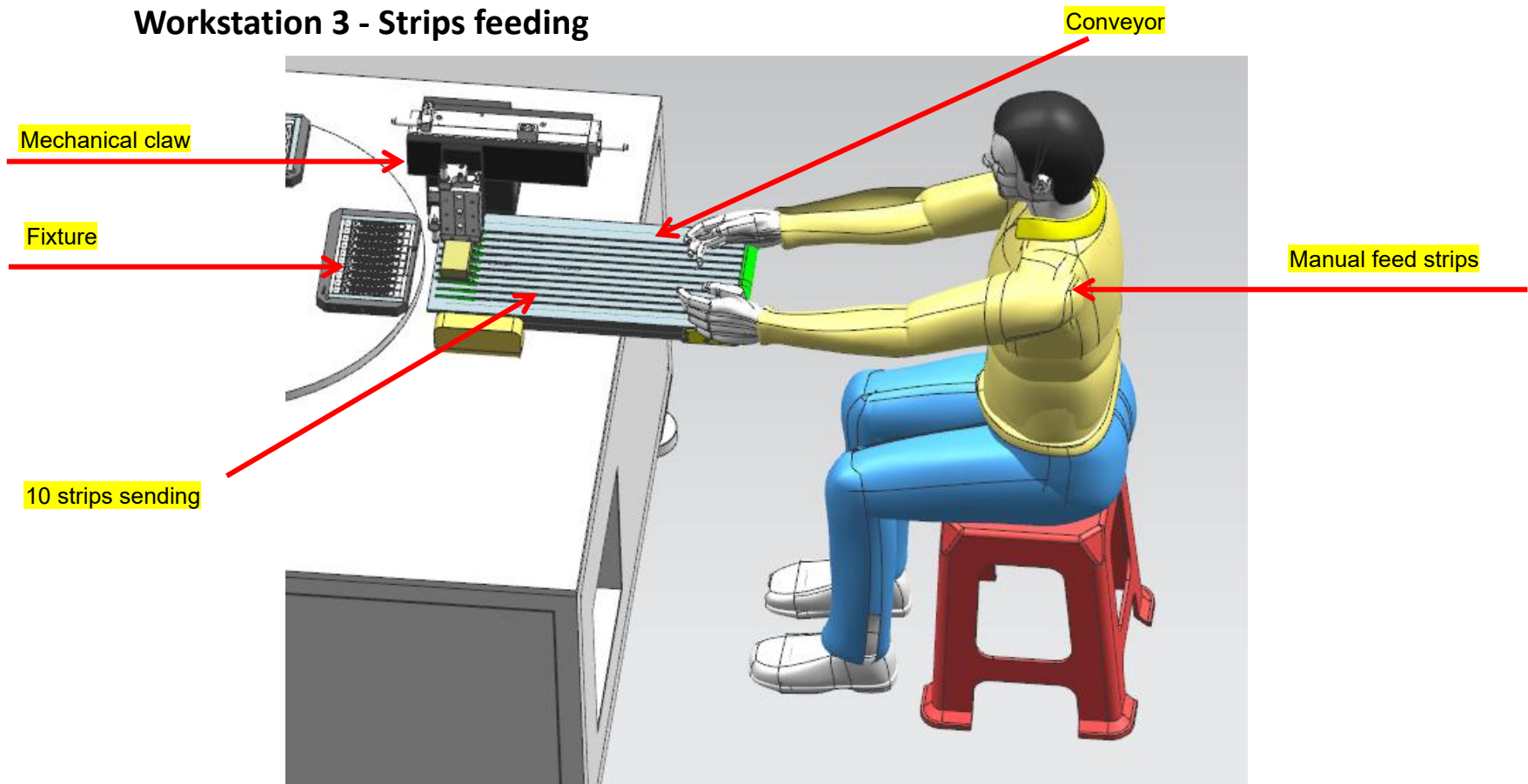

Test Strip Assembly Machine

Single Strip / 5 Strips or 10 Strips Per Sheet, Semi Auto Assembly

Machines Overview

1. Strips Assembly Machine

Workstation 4 - Pressing strips

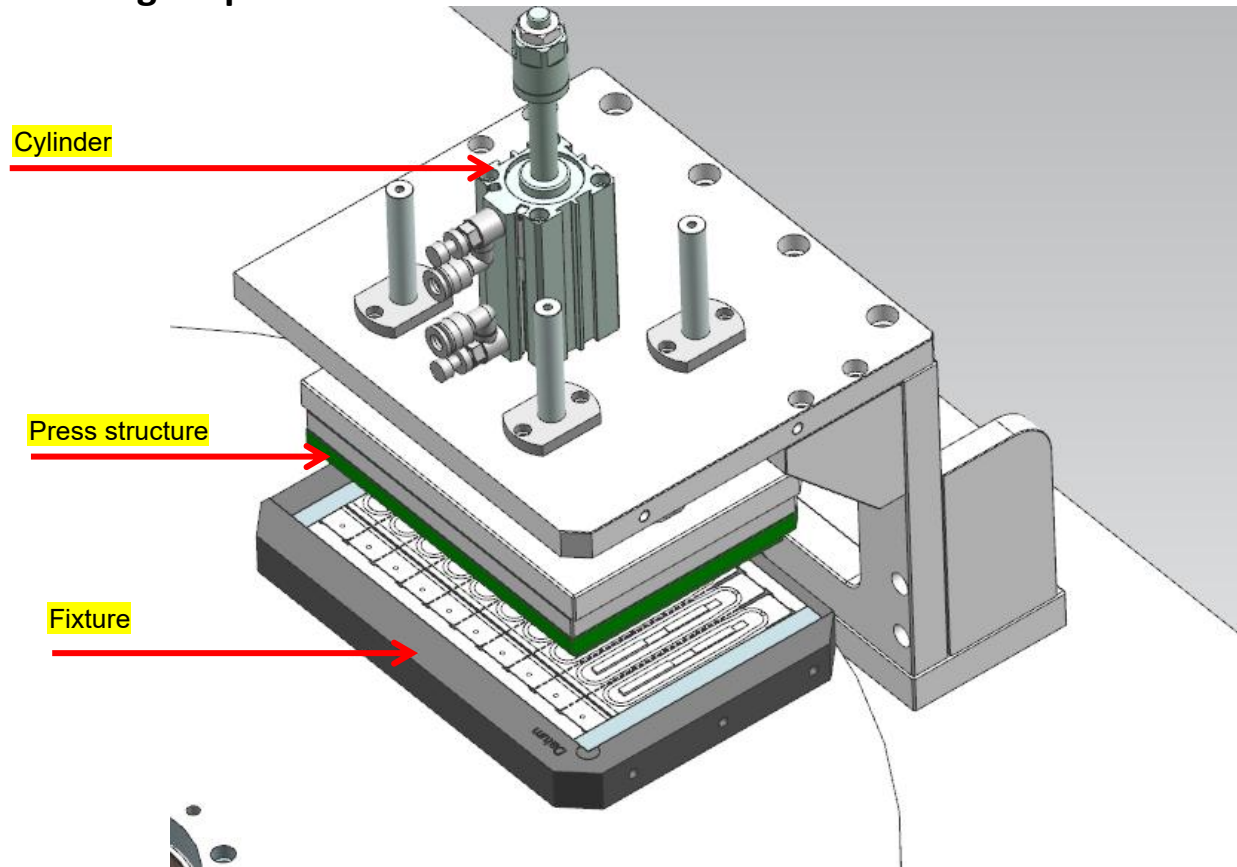

Test Strip Assembly Machine

Single Strip / 5 Strips or 10 Strips Per Sheet, Semi Auto Assembly

Machines Overview

1. Strips Assembly Machine

Parameters	
Capacity	1,000 strips/H
Activation	90%
Air supply	0.5~0.8MPa
Power supply	AC220V/50Hz
Internal power	DC/24V
Power	3.0 KW
Weight	800kg
Dimension	L1.6 * W1.2 * H1.8m
Wooden packing	---

Test Strip Assembly Machine

Single Strip / 5 Strips or 10 Strips Per Sheet, Semi Auto Assembly

2. Sealing Machine

a, manual feed the cover film

b, automated seal

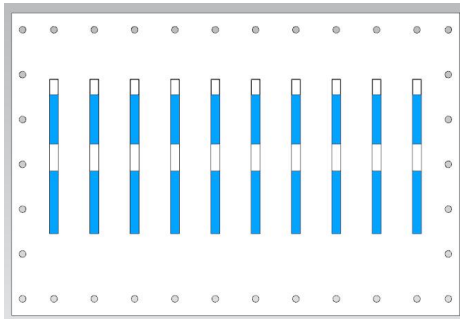

Strips with backing film

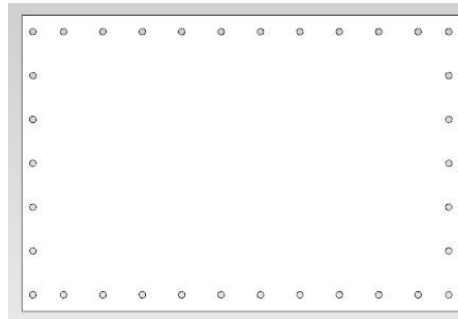

Cover film

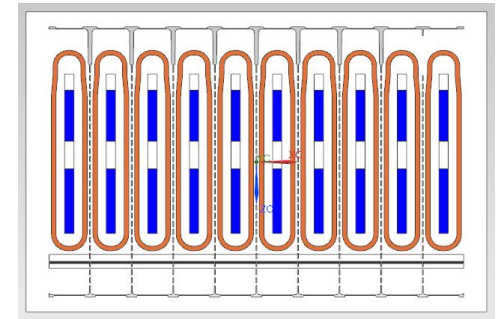

After sealed

Test Strip Assembly Machine

Single Strip / 5 Strips or 10 Strips Per Sheet, Semi Auto Assembly

Machines Overview

2. Sealing machine

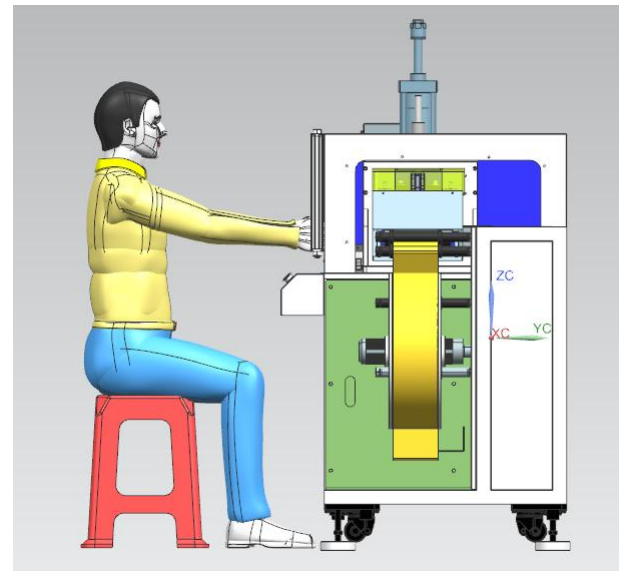
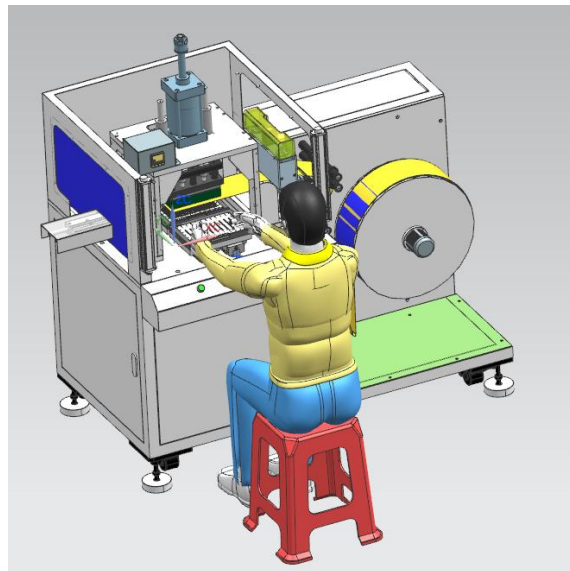
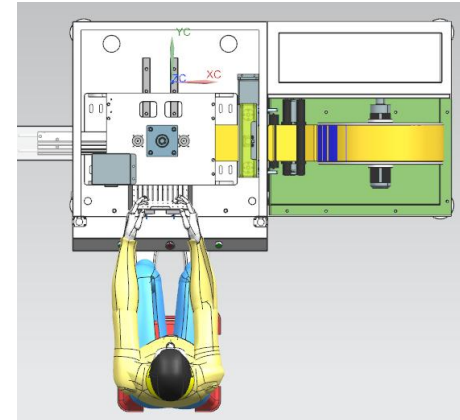
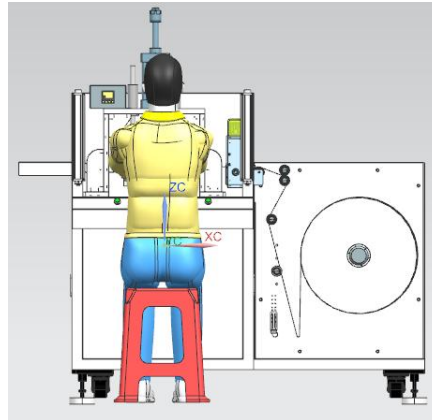

Test Strip Assembly Machine

Single Strip / 5 Strips or 10 Strips Per Sheet, Semi Auto Assembly

Machines Overview

2. Sealing machine

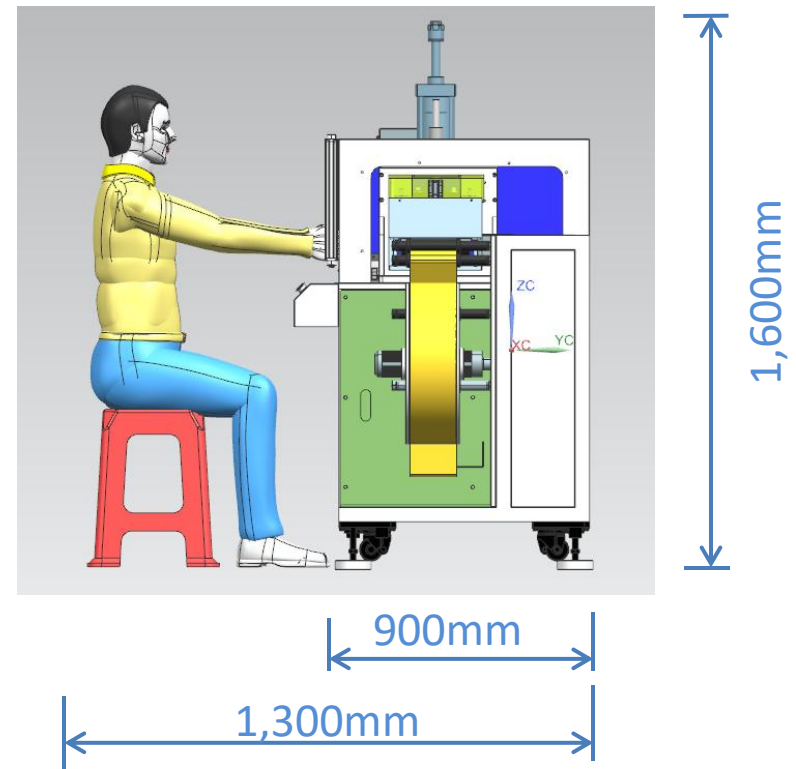
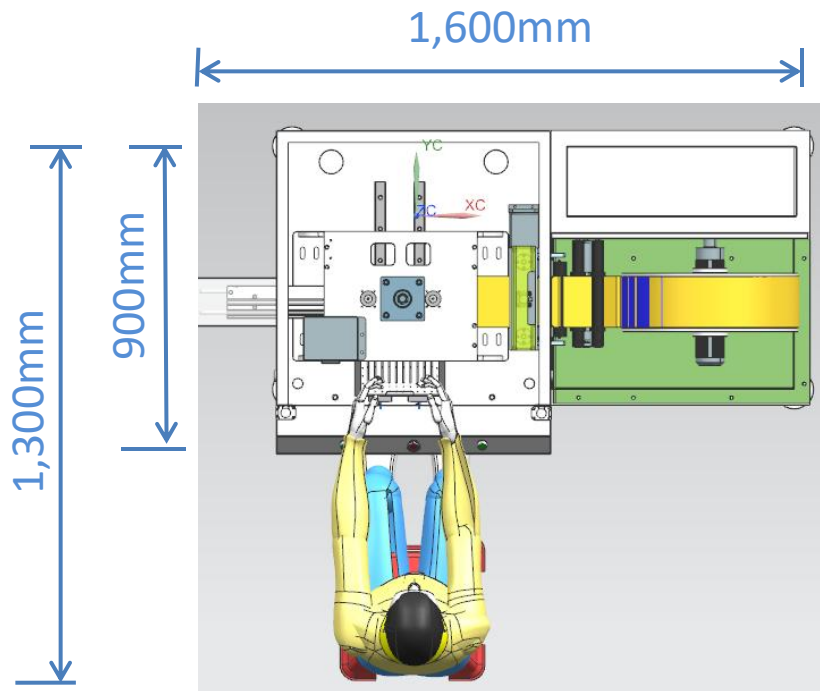

Test Strip Assembly Machine

Single Strip / 5 Strips or 10 Strips Per Sheet, Semi Auto Assembly

Machines Overview

2. Sealing machine

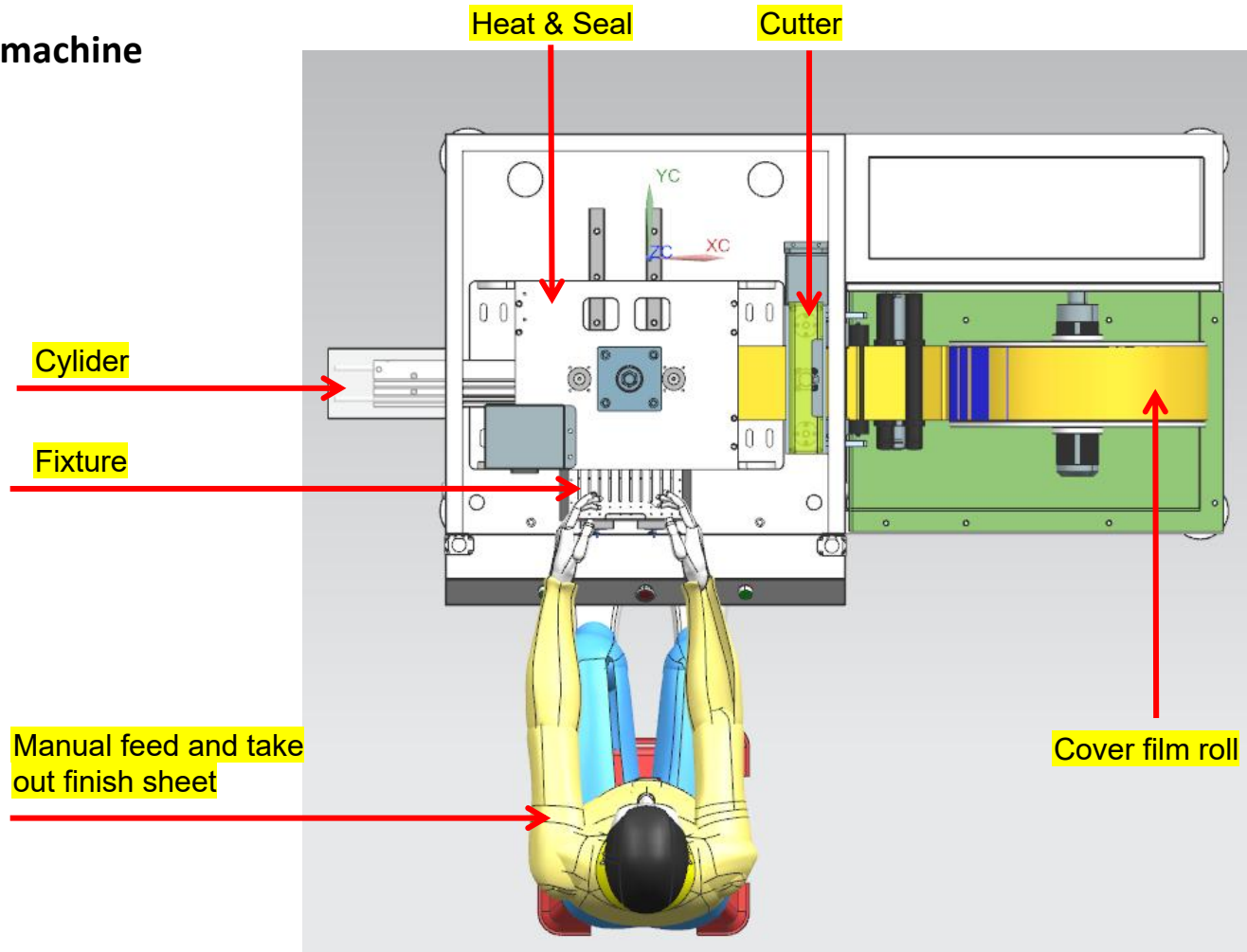

Test Strip Assembly Machine

Single Strip / 5 Strips or 10 Strips Per Sheet, Semi Auto Assembly

Machines Overview

2. Sealing machine

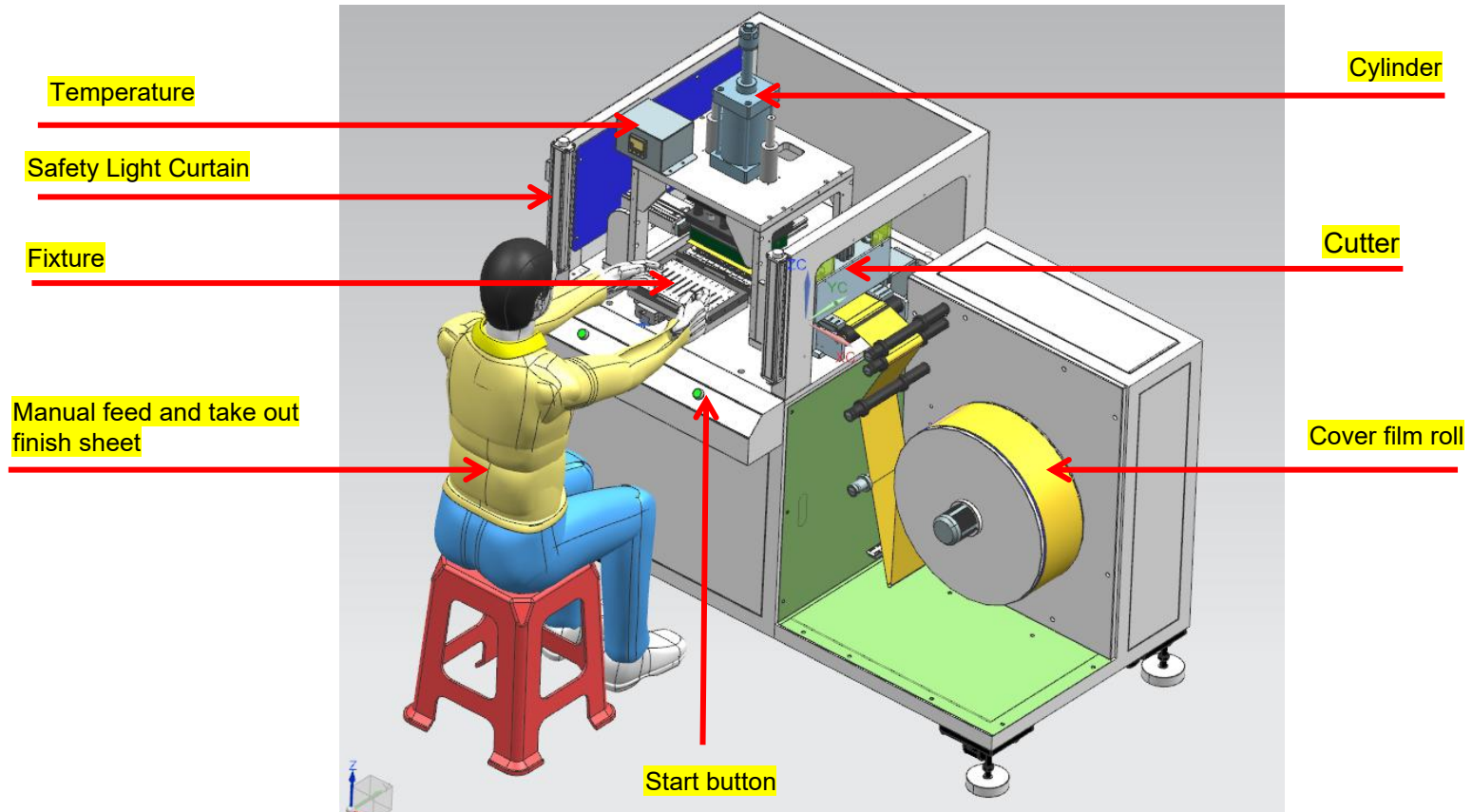

Test Strip Assembly Machine

Single Strip / 5 Strips or 10 Strips Per Sheet, Semi Auto Assembly

Machines Overview

2. Sealing machine

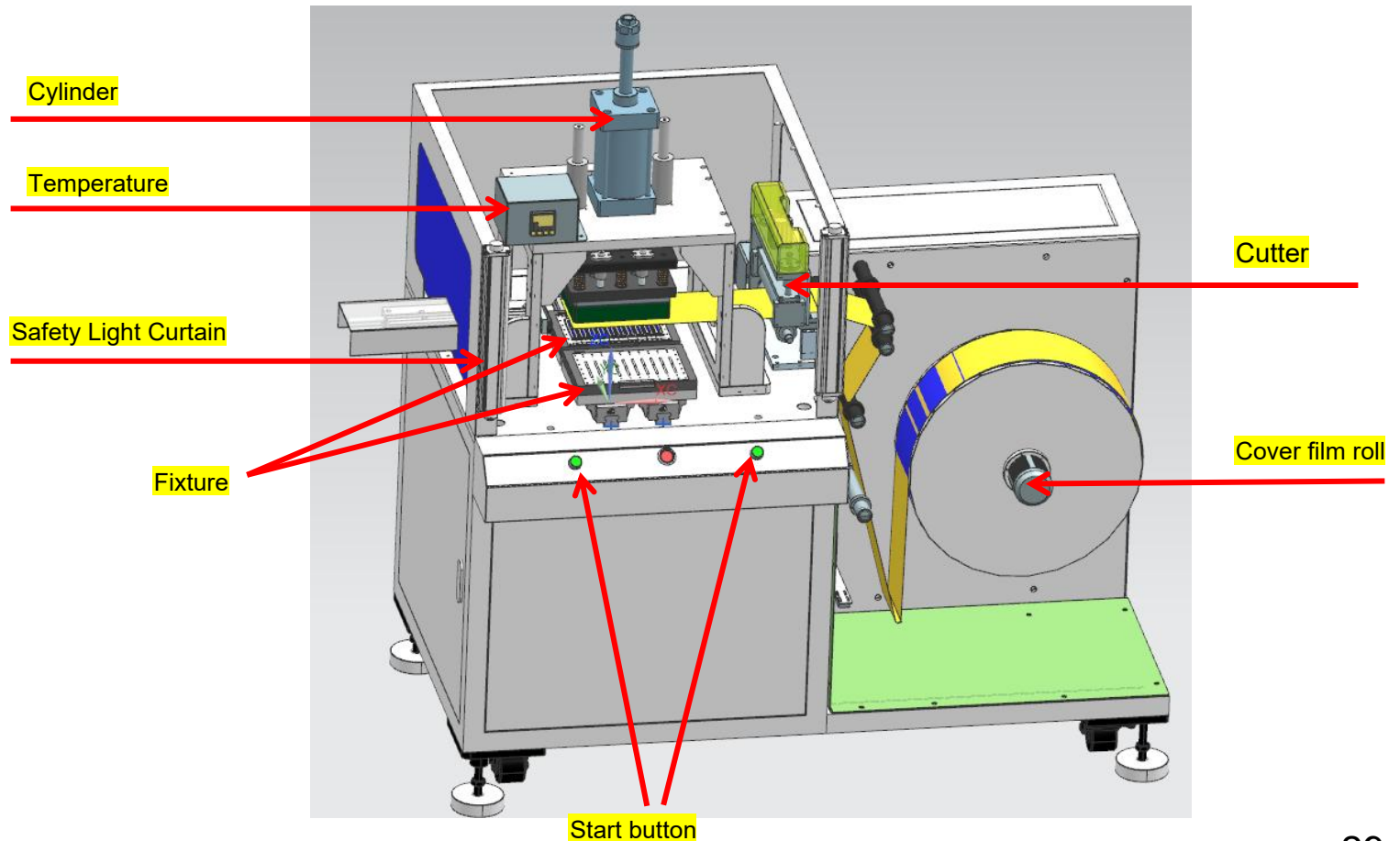

Test Strip Assembly Machine

Single Strip / 5 Strips or 10 Strips Per Sheet, Semi Auto Assembly

Machines Overview

2. Sealing machine

Parameters	
Capacity	1,000 strips/H
Activation	90%
Air supply	0.5~0.8MPa
Power supply	AC220V/50Hz
Internal power	DC/24V
Power	2.5 KW
Weight	600kg
Dimension	L1.6 * W1.3 * H1.6m
Wooden packing	---

Test Strip Assembly Machine

Single Strip / 5 Strips or 10 Strips Per Sheet, Semi Auto Assembly

3. Stop Line Cutting Machine (option)

a, manual feed the sheet

b, automate cutting the stop line

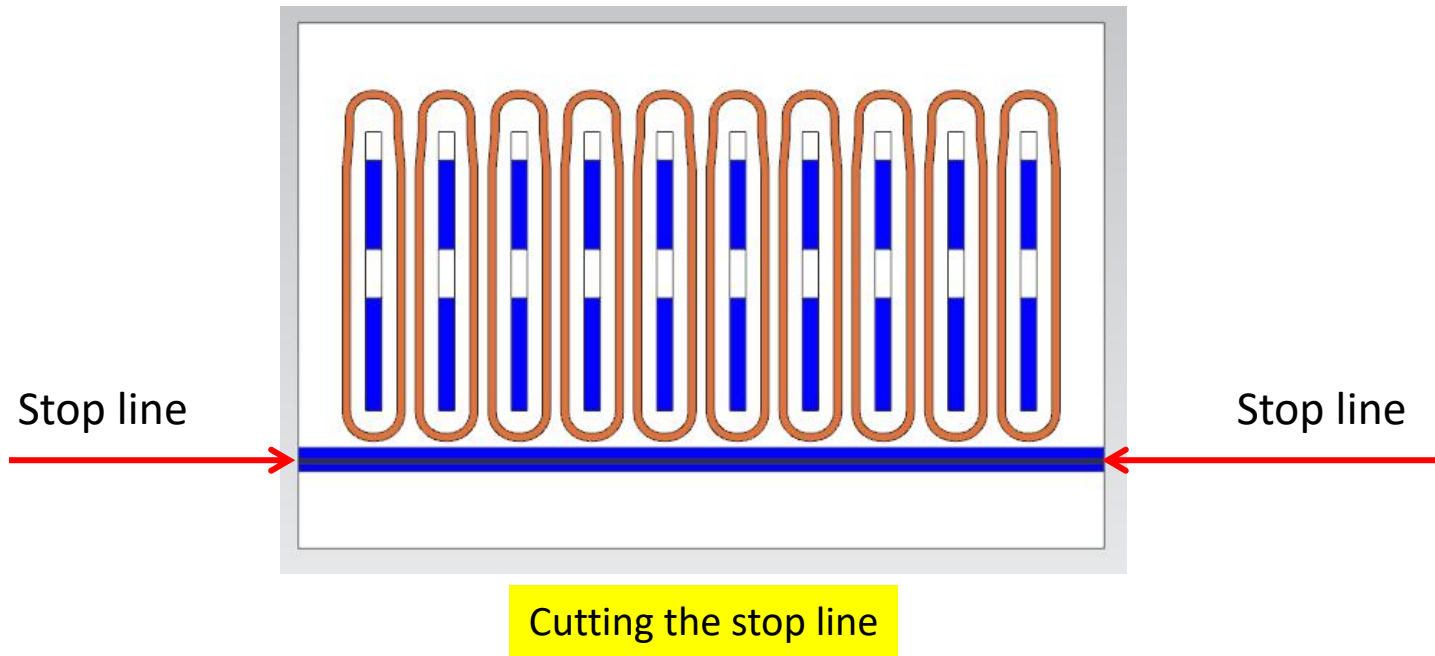

Test Strip Assembly Machine

Single Strip / 5 Strips or 10 Strips Per Sheet, Semi Auto Assembly

Machines Overview

3. Stop line cutting machine

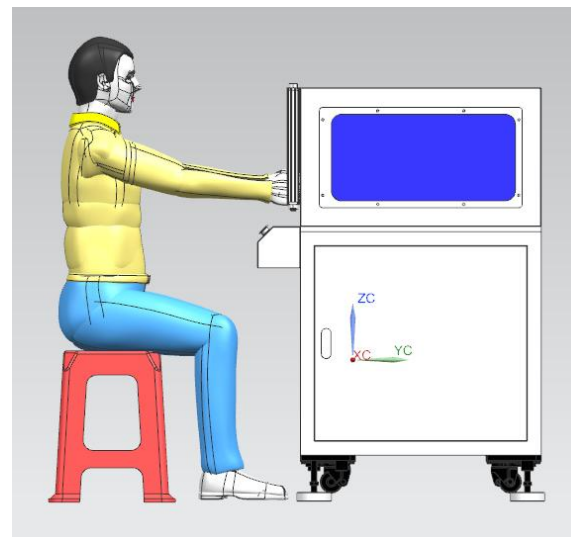
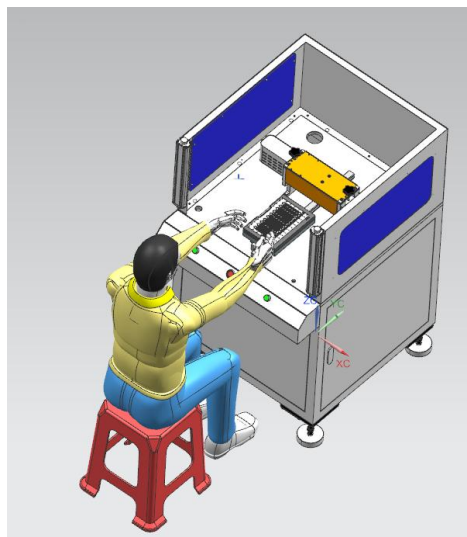
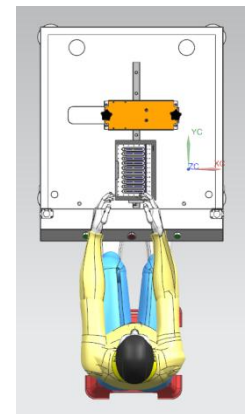
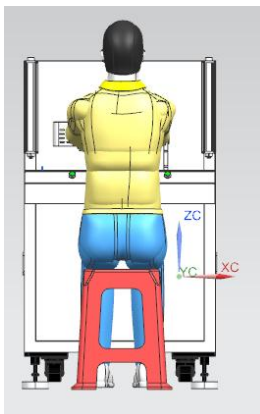

Test Strip Assembly Machine

Single Strip / 5 Strips or 10 Strips Per Sheet, Semi Auto Assembly

Machines Overview

3. Stop line cutting machine

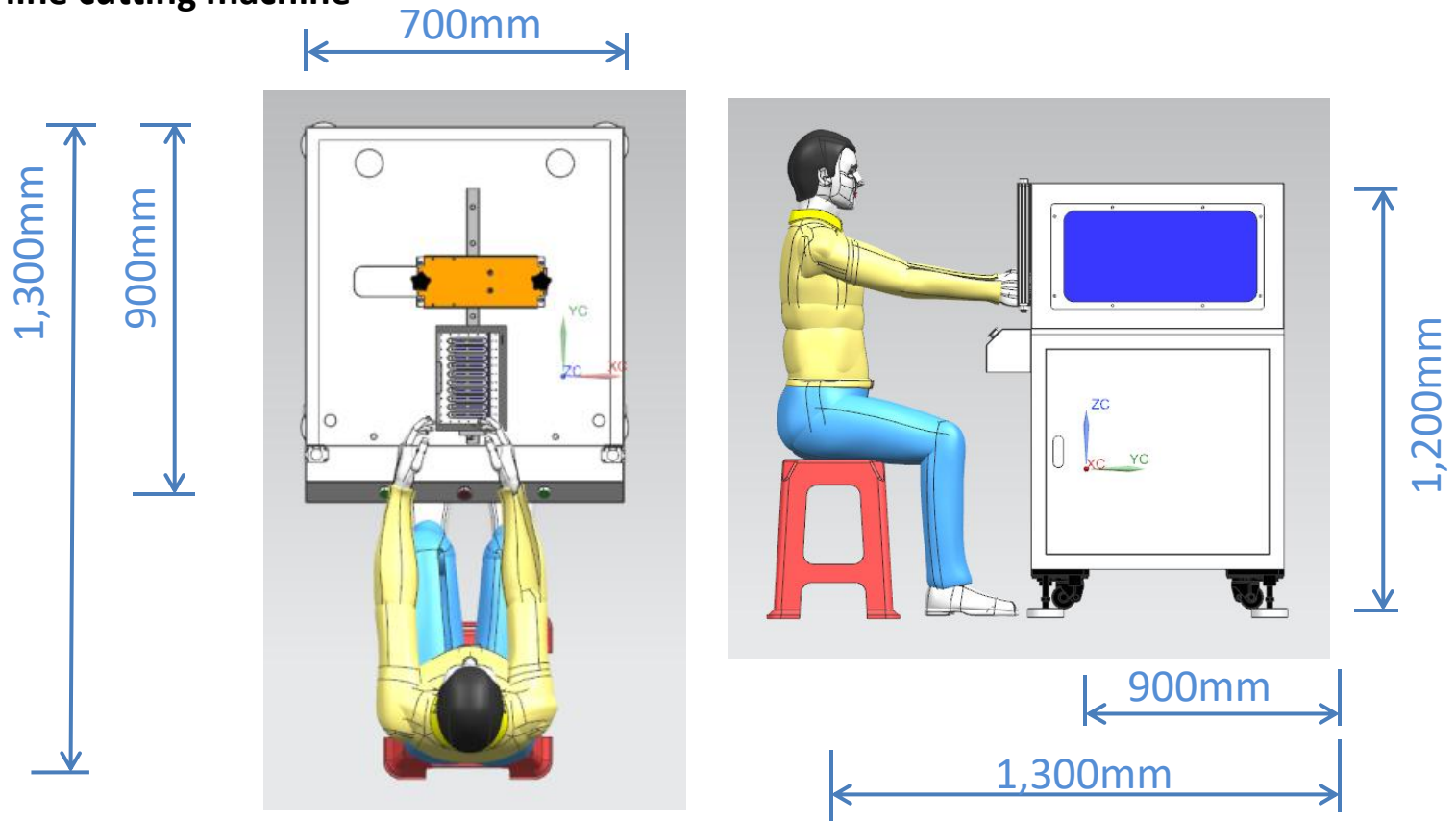

Test Strip Assembly Machine

Single Strip / 5 Strips or 10 Strips Per Sheet, Semi Auto Assembly

Machines Overview

3. Stop line cutting machine

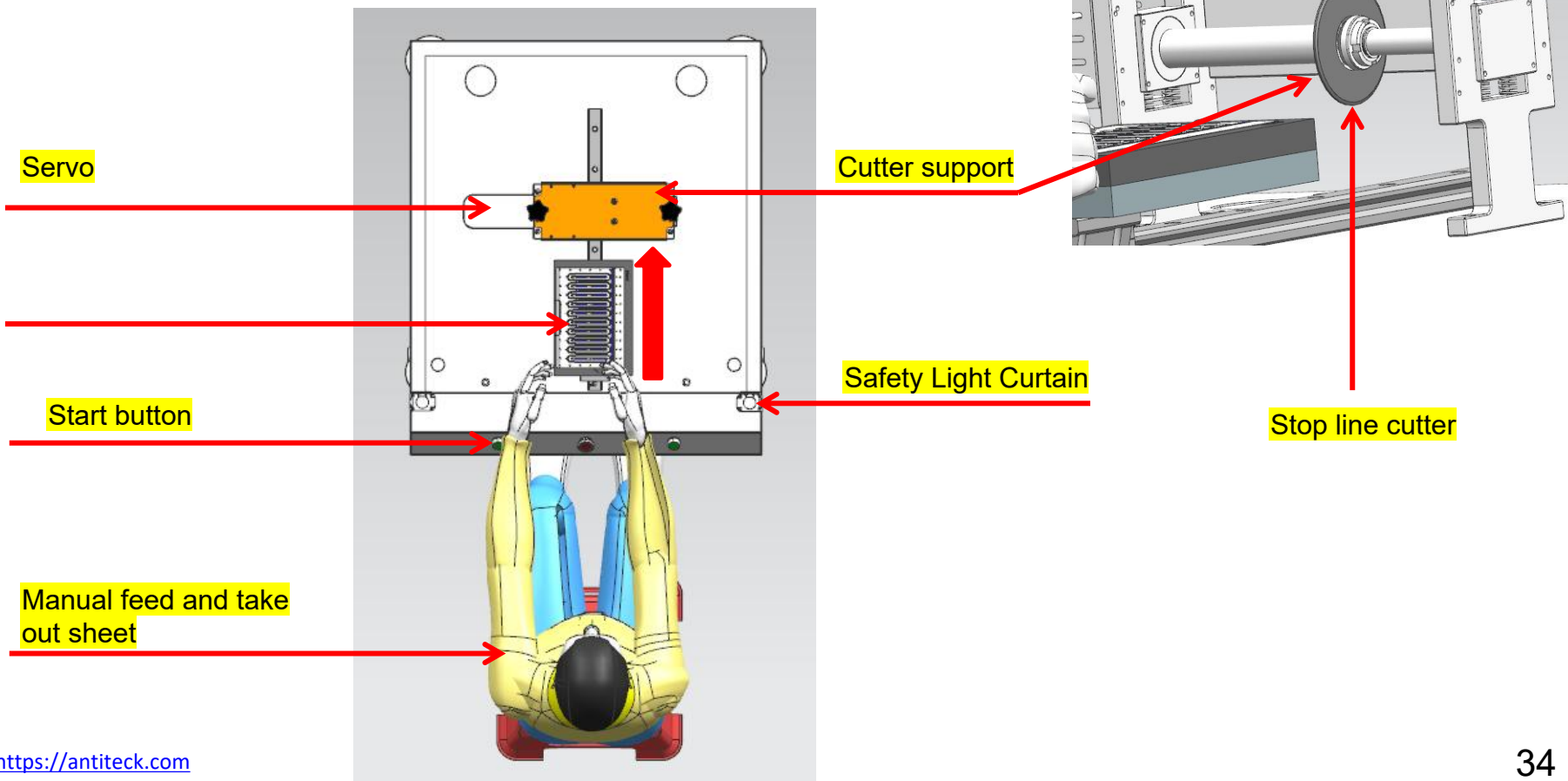

Test Strip Assembly Machine

Single Strip / 5 Strips or 10 Strips Per Sheet, Semi Auto Assembly

Machines Overview

3. Stop line cutting machine

Parameters	
Capacity	1,500 strips/H
Activation	90%
Air supply	0.5~0.8MPa
Power supply	AC220V/50Hz
Internal power	DC/24V
Power	1 KW
Weight	400kg
Dimension	L0.9 * W0.7 * H1.2m
Wooden packing	---

Test Strip Assembly Machine

Single Strip / 5 Strips or 10 Strips Per Sheet, Semi Auto Assembly

4. Easy Tear Line Cutting Machine

a, manual feed the sheet

b, automate cutting the easy tear line

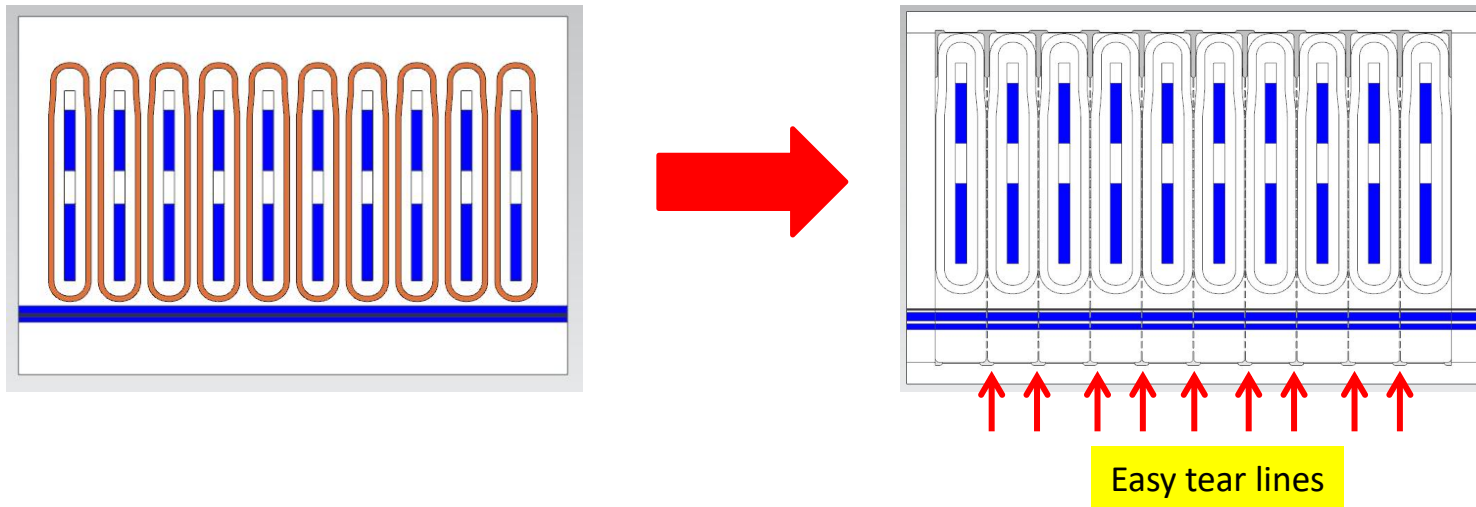

Test Strip Assembly Machine

Single Strip / 5 Strips or 10 Strips Per Sheet, Semi Auto Assembly

Machines Overview

4. Easy Tear Line Cutting Machine

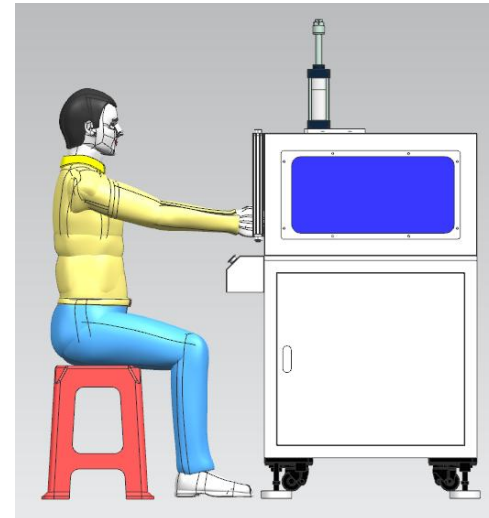
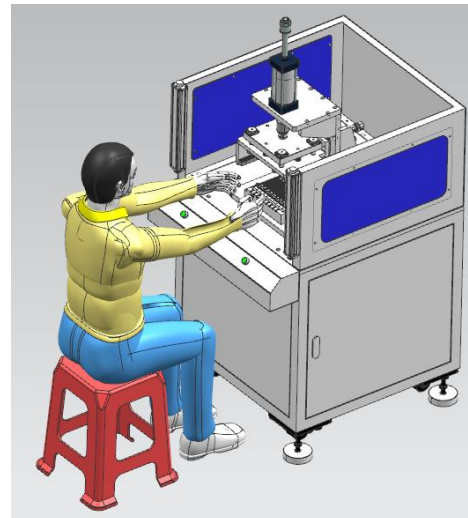
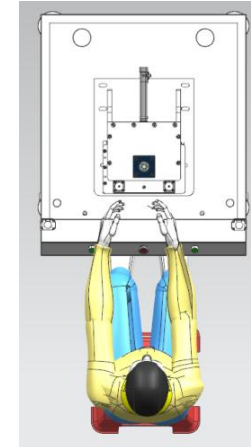
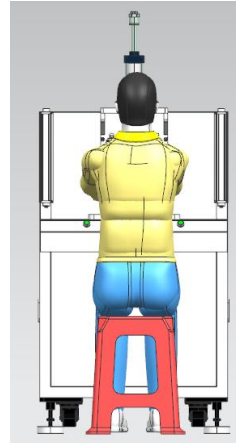

Test Strip Assembly Machine

Single Strip / 5 Strips or 10 Strips Per Sheet, Semi Auto Assembly

Machines Overview

4. Easy Tear Line Cutting Machine

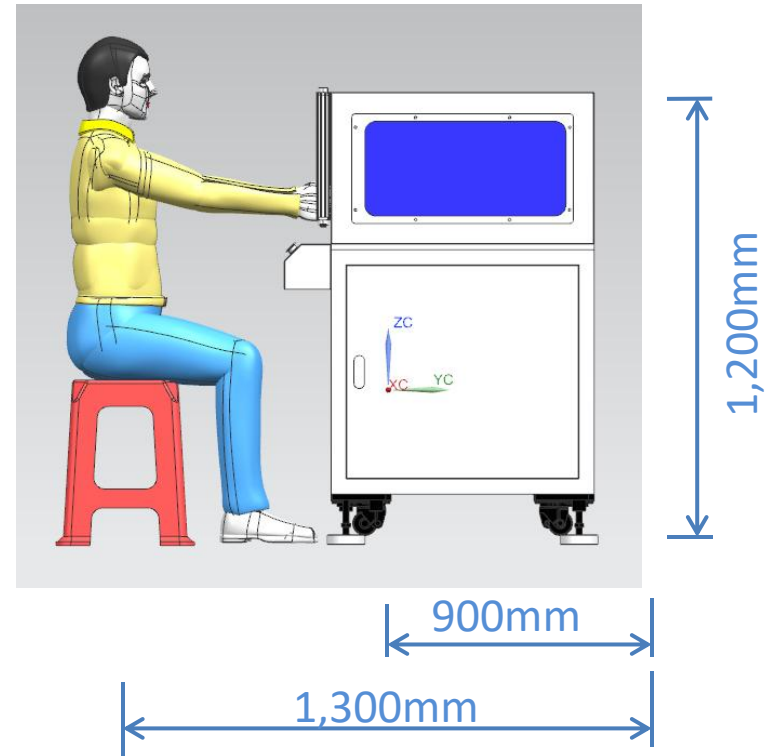
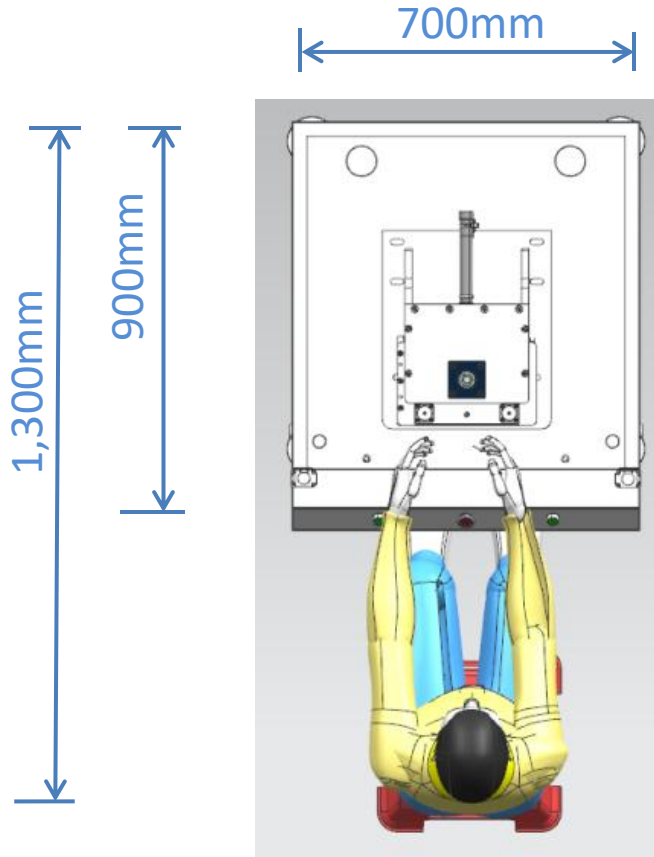

Test Strip Assembly Machine

Single Strip / 5 Strips or 10 Strips Per Sheet, Semi Auto Assembly

Machines Overview

4. Easy Tear Line Cutting Machine

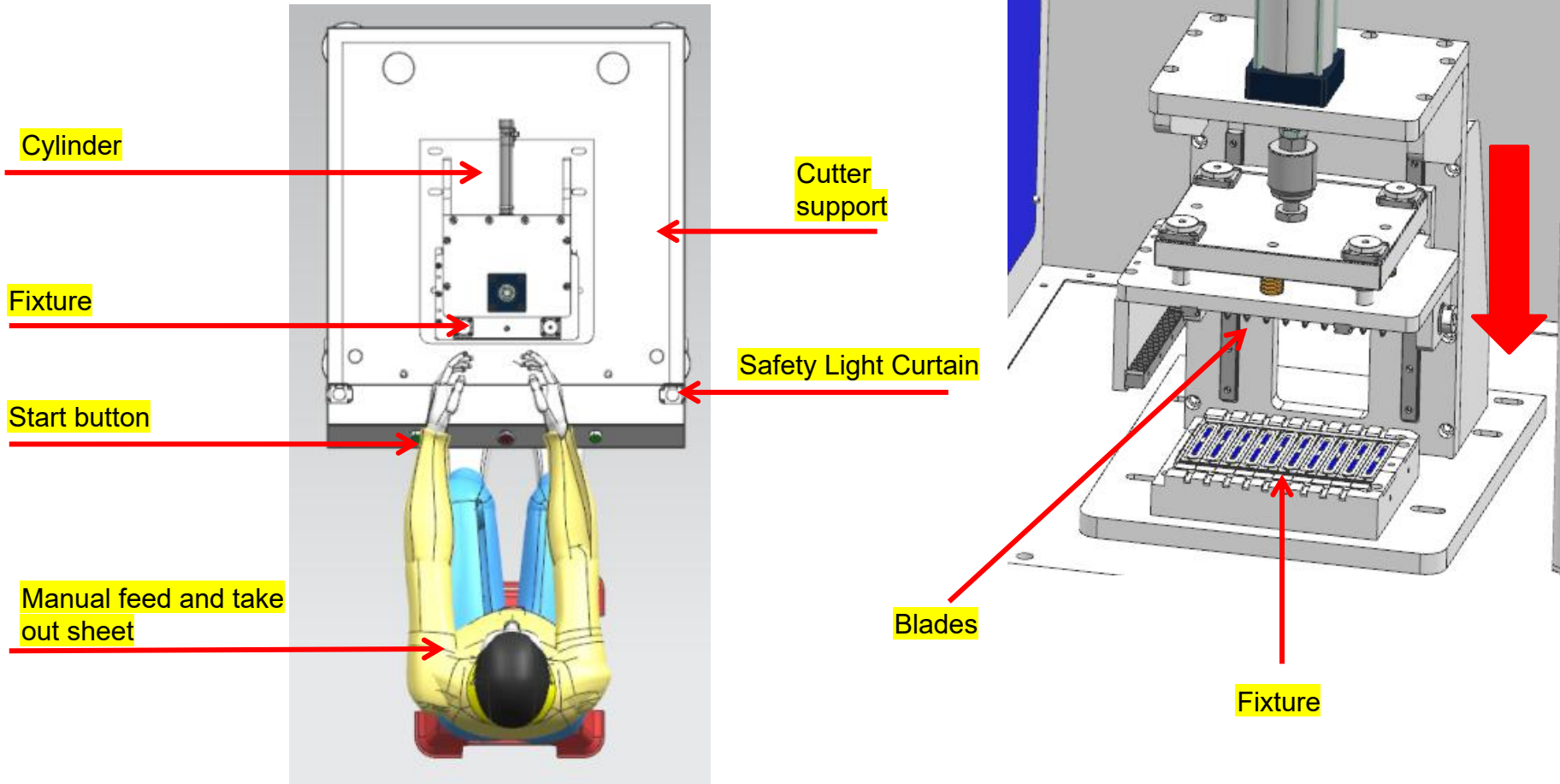

Test Strip Assembly Machine

Single Strip / 5 Strips or 10 Strips Per Sheet, Semi Auto Assembly

Machines Overview

4. Easy Tear Line Cutting Machine

Parameters	
Capacity	1,500 strips/H
Activation	90%
Air supply	0.5~0.8MPa
Power supply	AC220V/50Hz
Internal power	DC/24V
Power	1 KW
Weight	400kg
Dimension	L0.9 * W0.7 * H1.2m
Wooden packing	---

Test Strip Assembly Machine

Single Strip / 5 Strips or 10 Strips Per Sheet, Semi Auto Assembly

5. R Shaped Corner Cutting Machine

a, manual feed the sheet

b, automate cutting the R shaped corners

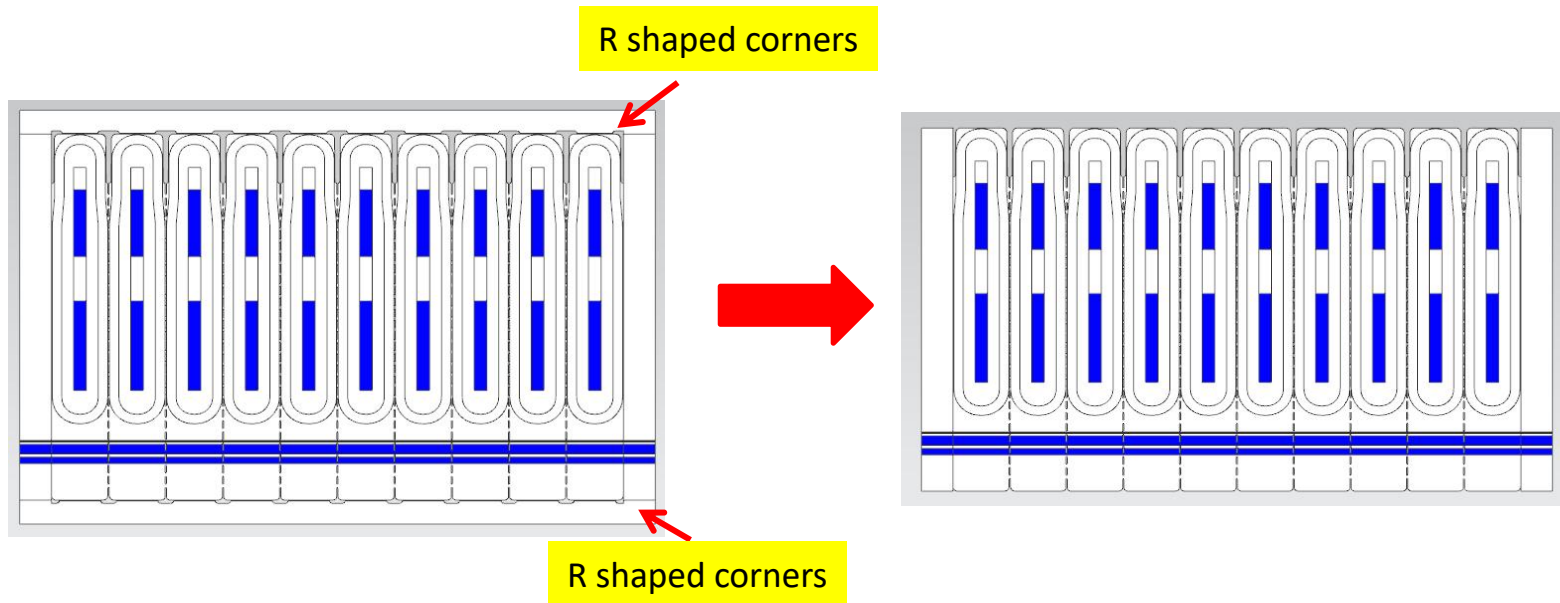

Test Strip Assembly Machine

Single Strip / 5 Strips or 10 Strips Per Sheet, Semi Auto Assembly

Machines Overview

5. R Shaped Corner Cutting Machine

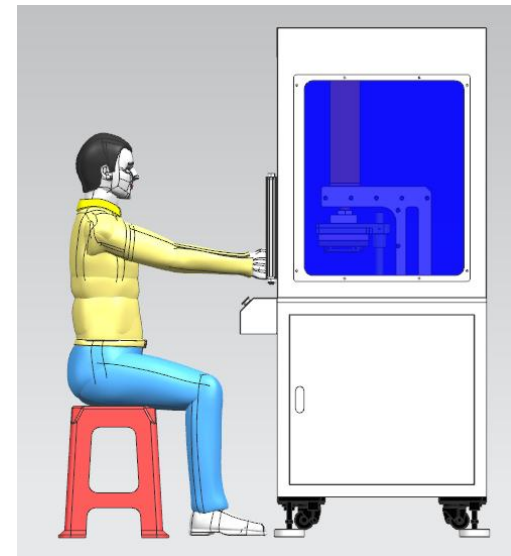
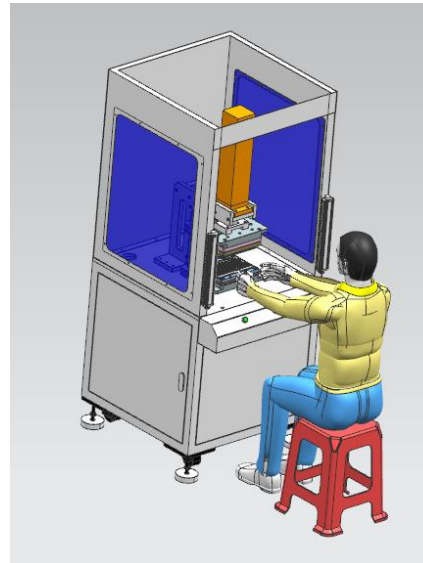
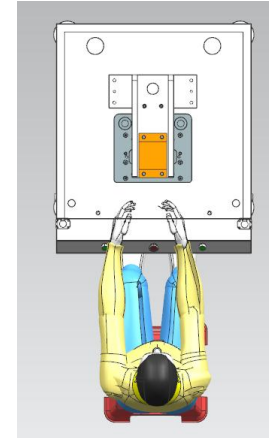
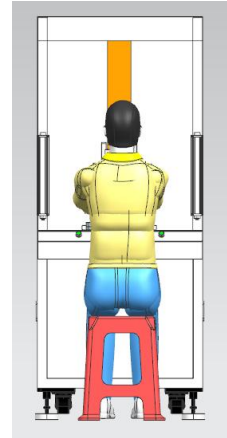

Test Strip Assembly Machine

Single Strip / 5 Strips or 10 Strips Per Sheet, Semi Auto Assembly

Machines Overview

5. R Shaped Corner Cutting Machine

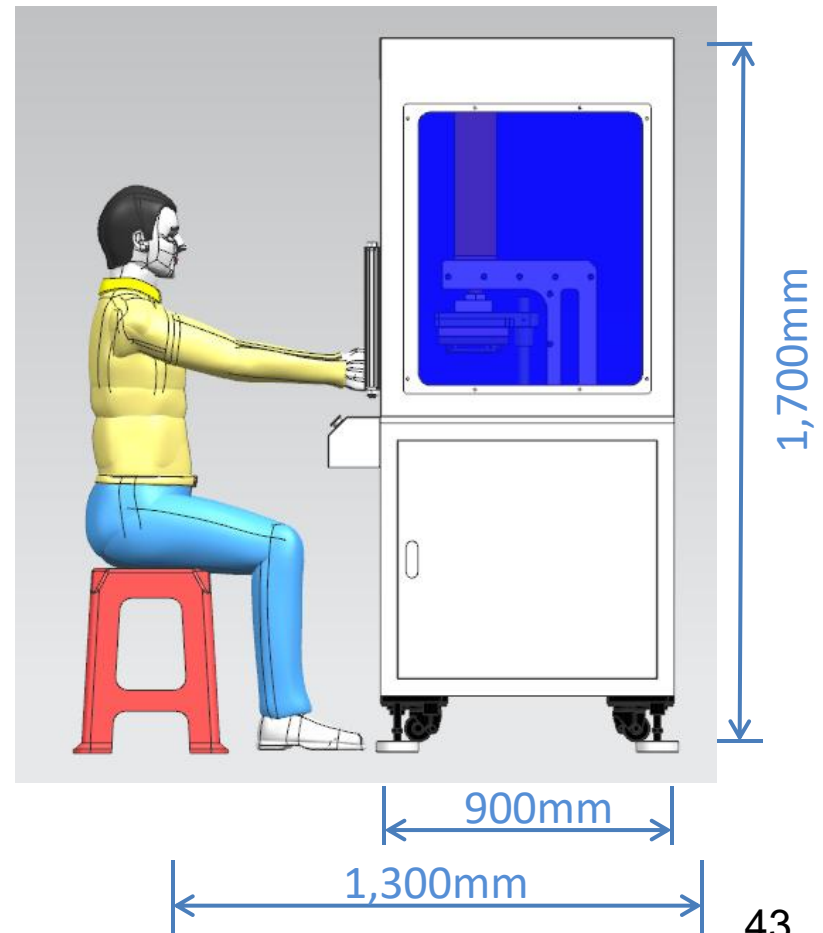
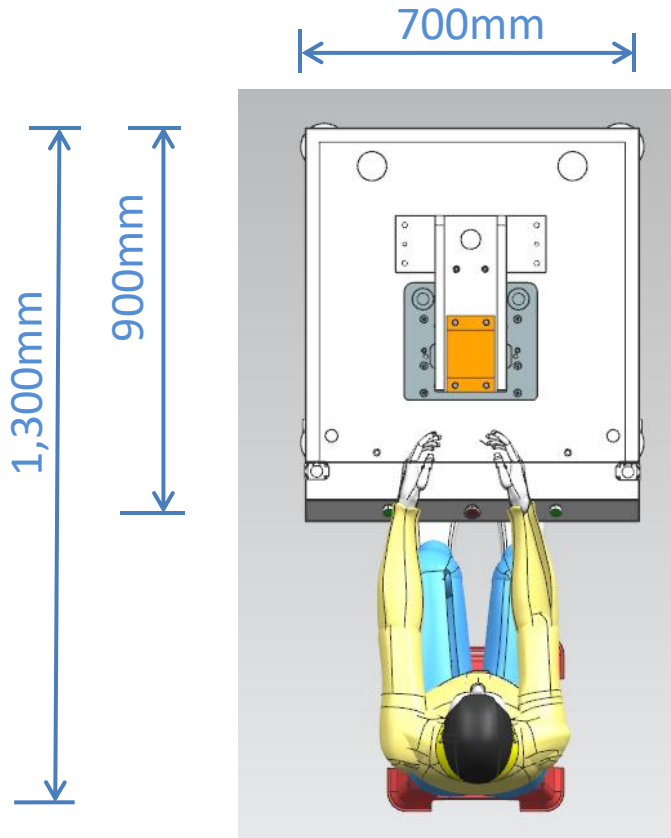

Test Strip Assembly Machine

Single Strip / 5 Strips or 10 Strips Per Sheet, Semi Auto Assembly

Machines Overview

5. R Shaped Corner Cutting Machine

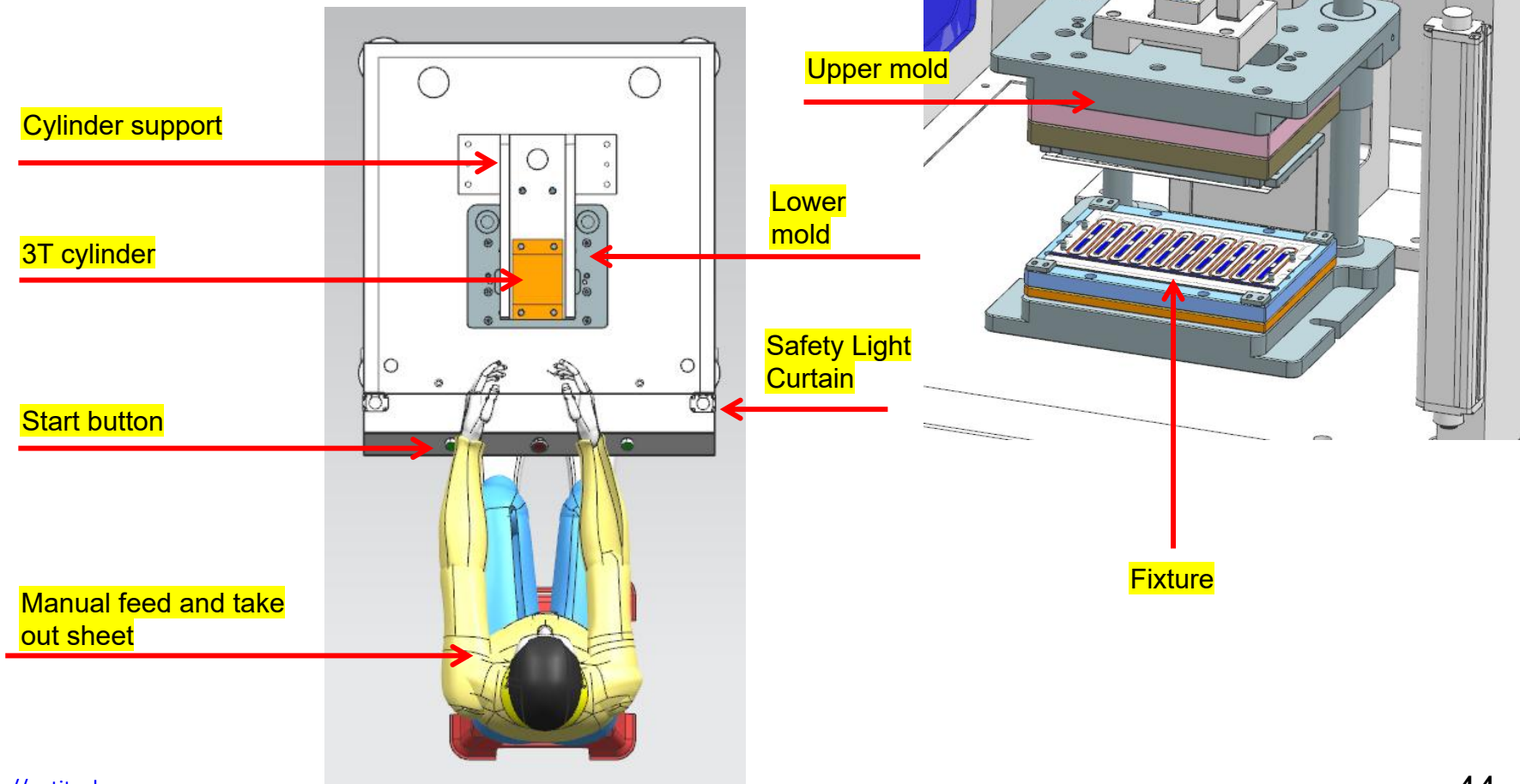

Test Strip Assembly Machine

Single Strip / 5 Strips or 10 Strips Per Sheet, Semi Auto Assembly

Machines Overview

5. R Shaped Corner Cutting Machine

Parameters	
Capacity	1,500 strips/H
Activation	90%
Air supply	0.5~0.8MPa
Power supply	AC220V/50Hz
Internal power	DC/24V
Power	1 KW
Weight	400kg
Dimension	L0.9 * W0.7 * H1.7m
Wooden packing	---

Test Strip Assembly Machine

Single Strip / 5 Strips or 10 Strips Per Sheet, Semi Auto Assembly

6. Final Cutting

a, manual feed the sheet

b, automate cutting the side material

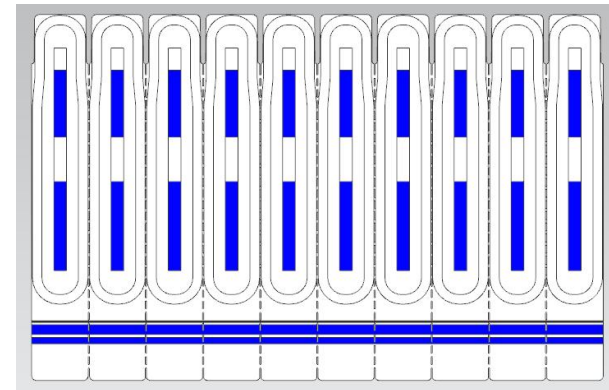
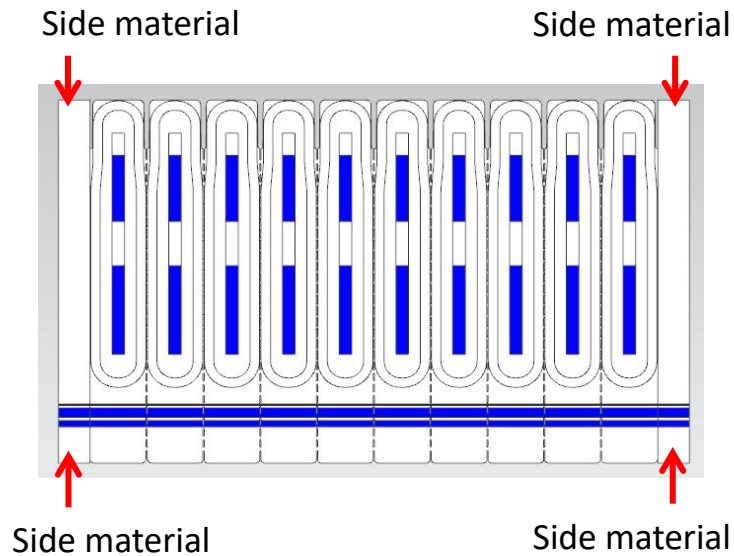

Final sheet - 10 Strips/sheet

Test Strip Assembly Machine

Single Strip / 5 Strips or 10 Strips Per Sheet, Semi Auto Assembly

Machines Overview

5. Final Cutting Machine

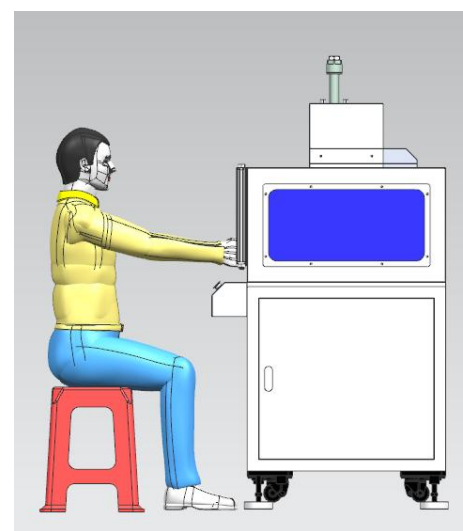
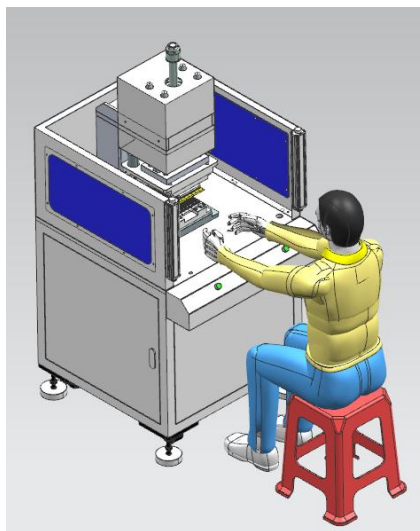
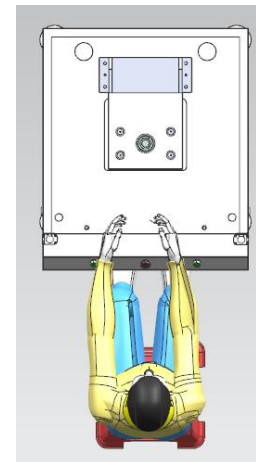
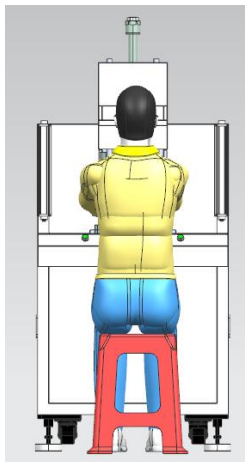

Test Strip Assembly Machine

Single Strip / 5 Strips or 10 Strips Per Sheet, Semi Auto Assembly

Machines Overview

5. Final Cutting Machine

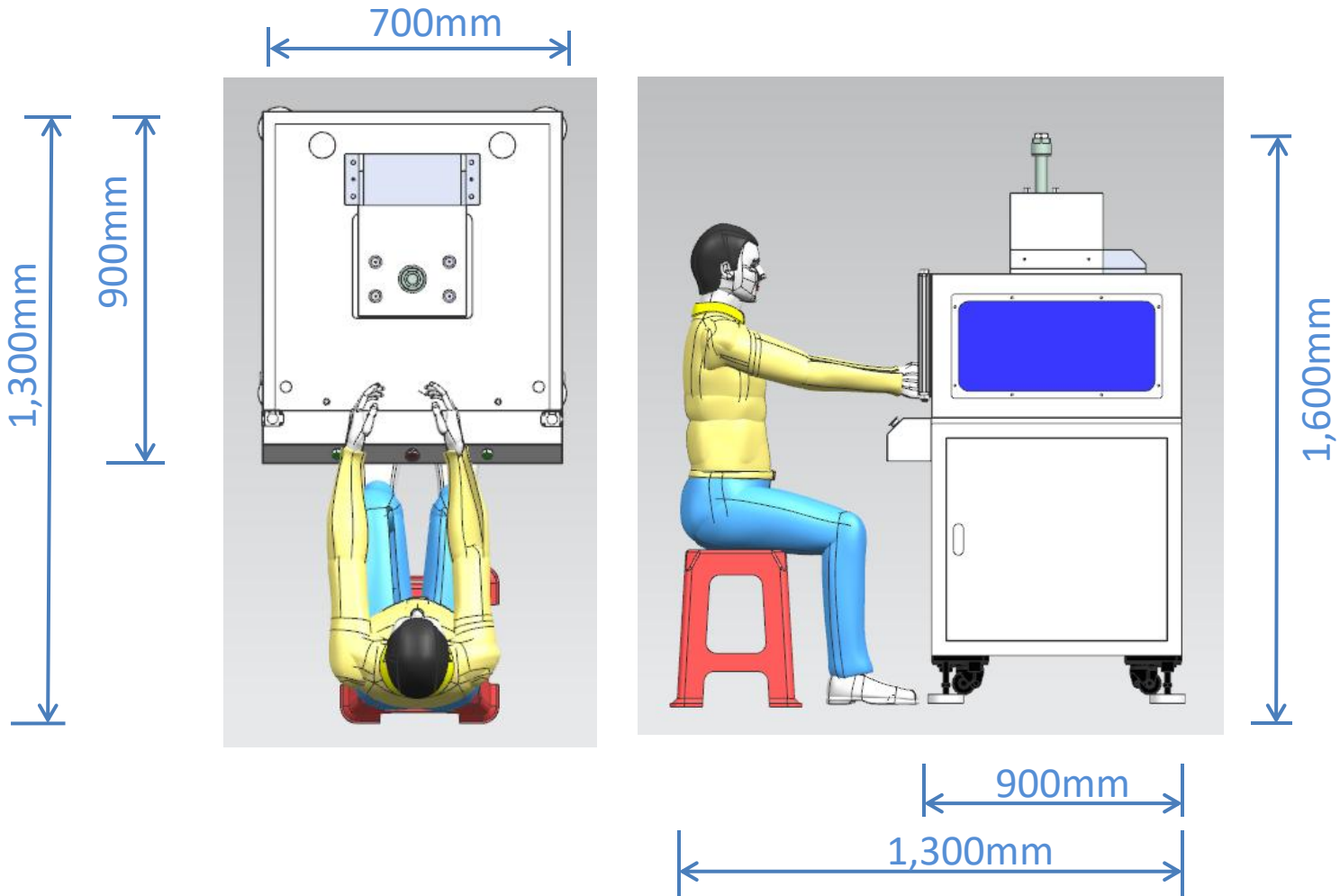

Test Strip Assembly Machine

Single Strip / 5 Strips or 10 Strips Per Sheet, Semi Auto Assembly

Machines Overview

5. Final Cutting Machine

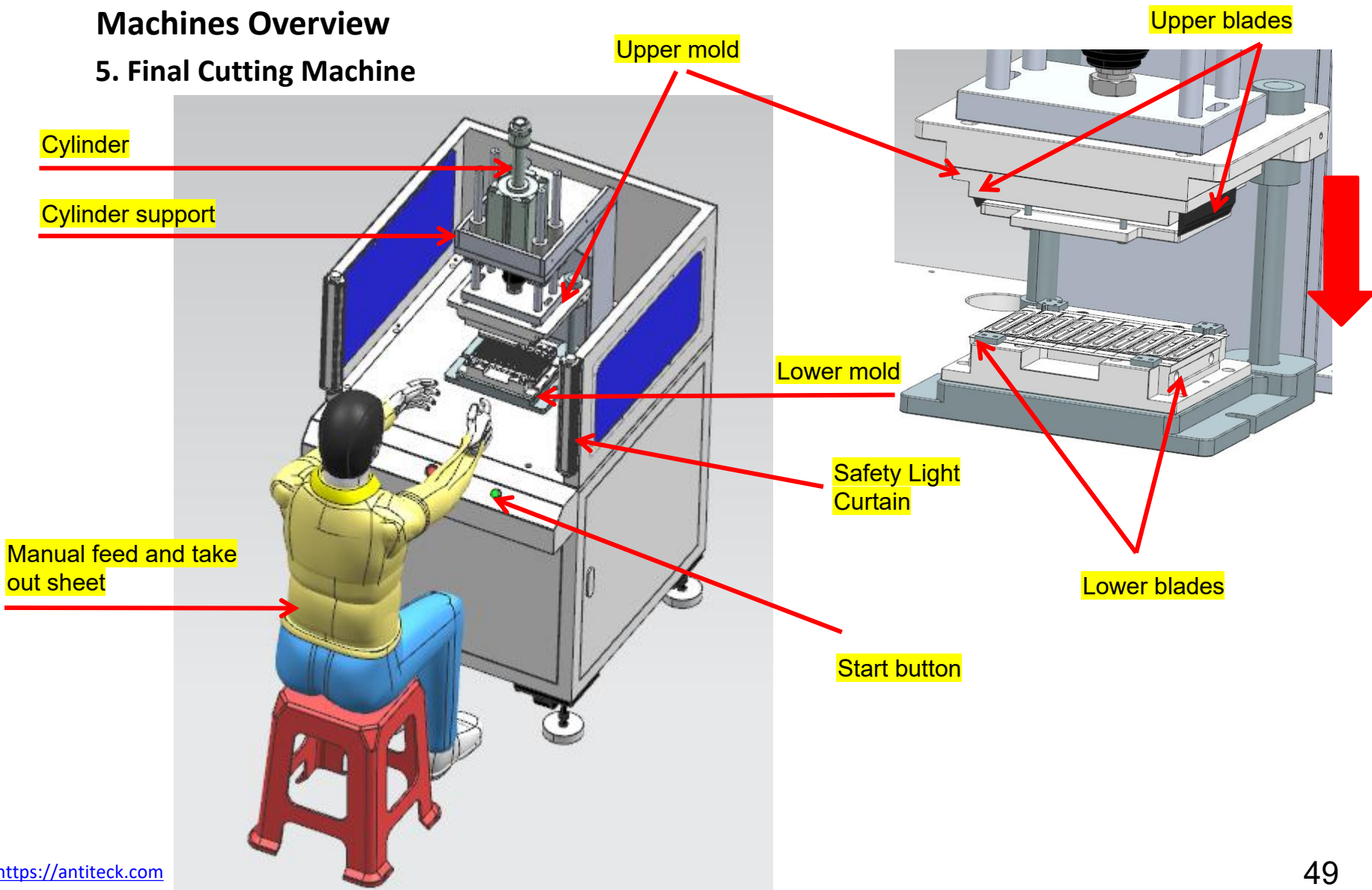

Test Strip Assembly Machine

Single Strip / 5 Strips or 10 Strips Per Sheet, Semi Auto Assembly

Parameters	
Capacity	1,500 strips/H
Activation	90%
Air supply	0.5~0.8MPa
Power supply	AC220V/50Hz
Internal power	DC/24V
Power	1 KW
Weight	400kg
Dimension	L0.9 * W0.7 * H1.6m
Wooden packing	---

Test Strip Assembly Machine

Single Strip / 5 Strips or 10 Strips Per Sheet, Semi Auto Assembly

Key components	
PLC	Mitsubishi/Panasonic/other
Operation system	ANTITECK
Servo	Inovance/KNK
Relay	Schneider/CHNT
Sensor	OMRON/Panasonic
Cylinder	SMC/AIRTAC
Solenoid valve	SMC/AIRTAC
Connector	SMC/AIRTAC

What ANTITECK can do?

For automation product line

non-standard automatic machine

Communication

1. Customer provide details
2. Provide samples for machine design

Design

Start designing

Equipments manufacturing

In manufacturing process

Installation Commissioning

Deliver machine
Installation
Commissioning